

80
YEARS
OF TORQUE
INNOVATION

EXPERTS BY CHOICE



Norbar[®]
Norbar Torque Tools



GENERIC

| | | |
|-------------------------|-------------------------------|-----------------|
| Accuracy (%) | Torque & Angle | Digital Display |
| Single Scale | Dual Scale | Multi Scale |
| Calibration Certificate | UKAS Accredited Certification | IP Rated |
| Bluetooth Enabled | Case Included | |

SCREWDRIVERS & TORQUE WRENCHES

| | | |
|--------------------|----------------------------|-------------------------|
| Ratchet | Torque Handle | Fixed |
| Adjustment Lock | Declaration of Conformance | Calibration Certificate |
| 1/4 Hex Bit Holder | | |

MANUAL TORQUE MULTIPLIERS

| | | |
|---------------------|----------------------|--|
| Adjustable Reaction | Anti Wind-up Ratchet | |
|---------------------|----------------------|--|

POWERED TORQUE TOOLS

| | | |
|---------------------|----------------|------------------------------|
| Adjustable Reaction | 2 Speed | Air Consumption - litres/sec |
| Lifting Attachment | Bi-Directional | |

TORQUE MEASUREMENT INSTRUMENTS

| | | |
|-------------------|--------------|--|
| Multi Transducers | Back-up Data | |
|-------------------|--------------|--|

HARSH ENVIRONMENT INSTRUMENTS

| | | |
|-------------------|--|--|
| Multi Transducers | | |
|-------------------|--|--|

ULTRASONIC MEASUREMENT

| | | |
|--------------|--|--|
| Back-up Data | | |
|--------------|--|--|

CUSTOMER RELATIONS

CONTACT DETAILS

New Sales
Direct Tel +44 (0)1295 753600
Email sales@norbar.com

After Sales Service
Tel +44 (0)1295 753635
Email service@norbar.com

Norbar Torque Tools Ltd
Wildmere Road, Banbury
Oxfordshire, OX16 3JU
UNITED KINGDOM
www.norbar.com

OFFICE OPENING HOURS

Monday - Thursday 07:30 - 17:00
Friday 07:30 - 16:15

NORBAR SOCIAL MEDIA



Norbar Torque Tools Ltd



Norbar Torque Tools



Norbar Torque Tools Ltd





Welcome to NORBAR



John Reynertson
Managing Director
Norbar Torque Tools

“From our humble beginnings over 80 years ago in a small workshop in North Bar, to our latest purpose-built factory on Wildmere Road, Norbar has pioneered many of today’s solutions for torque control. Our offices around the world are excellent at taking core Banbury product and developing it for your use in your application. From manual torque wrenches to sophisticated control systems, we are still dedicated to being the best at what we do.

Norbar is now a member of the Snap-on Incorporated family of companies and is proud to be part of a business which has beliefs, values and a vision closely aligned with those that Norbar was founded on. We still strive to be "The best torque tool company in the world. Respected, profitable and a great place to work.”



FASTORQ is a preferred global provider of precision bolt loading and removal solutions. FASTORQ is a pioneer of the hydraulic tools industry and today designs, manufactures and sells an innovative line of bolting solutions including a complete line of hydraulic, electric and pneumatic tools, as well as design resources to customise existing tools or create one-of-a-kind bolting solutions.



From torque wrenches to torque screwdrivers, interchangeable heads for torque wrenches and the first torque analyzers and calibration instruments, Paul Sturtevant and Frank Livermont led the way. Sturtevant Richmond continues to shape the industry with game-changing innovation including the development of radio-equipped torque hand tools that connect to a process monitor.



Mountz began with a passion for creating exceptional tools and a deep understanding of the critical role torque plays in the world. The Mountz story started in a Cupertino garage in 1965, and over the decades, the company has grown into a leader in torque innovation. From pioneering the first electronic torque calibrator to continuously challenging industry norms, Mountz has remained dedicated to helping customers achieve precision, accuracy, and quality in their manufacturing processes.



GLOBAL SERVICE



United Kingdom
+44 (0)1295 753600
sales@norbar.com



Australia
+61 (0)8 8292 9777
norbar@norbar.com.au



USA
+1 866 667 2272
inquiry@norbar.us



NVLAP Lab Code 200596-0



China
+86 21 6145 0368
sales@norbar.com.cn



India
+91 22 4778 8110
enquiry@norbar.in



FASTORQ
+1 281 449 6466
esales@fastorq.com



Sturtevant Richmond
+1 800 877 1347
customerservice@srtorque.com



Mountz
+1 408 850 9978
sales@mountztorque.com





Norbar are the world's leading specialist in torque control and we are engaged solely in the design, development and production of torque tightening and measuring equipment.

We have distributors of our torque control products in more than 60 countries around the world.





TABLE OF CONTENTS



Torque Screwdrivers & Torque Wrenches 13

Versatile, accurate and easy torquing



Electronic Torque Wrenches 31

An extensive range of high quality torque wrenches



HandTorque Multipliers 40

Multipliers that use a compact, epicyclic gearbox that accurately multiply the input torque provided by a torque wrench



Powered Torque Tools 49

A comprehensive range of electronic and pneumatic torque tools



Connected Tools 75

Systems designed to error-proof processes where highly customised products are assembled



Torque Measurement 78

Norbar's torque measuring instruments are renowned for high accuracy and superb reliability

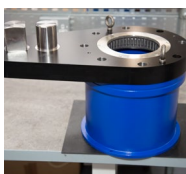

Hydraulic Fixtures 105

The Hydraulic Tool Calibration Fixture is a robust device that allows accurate testing of hydraulic torque wrenches



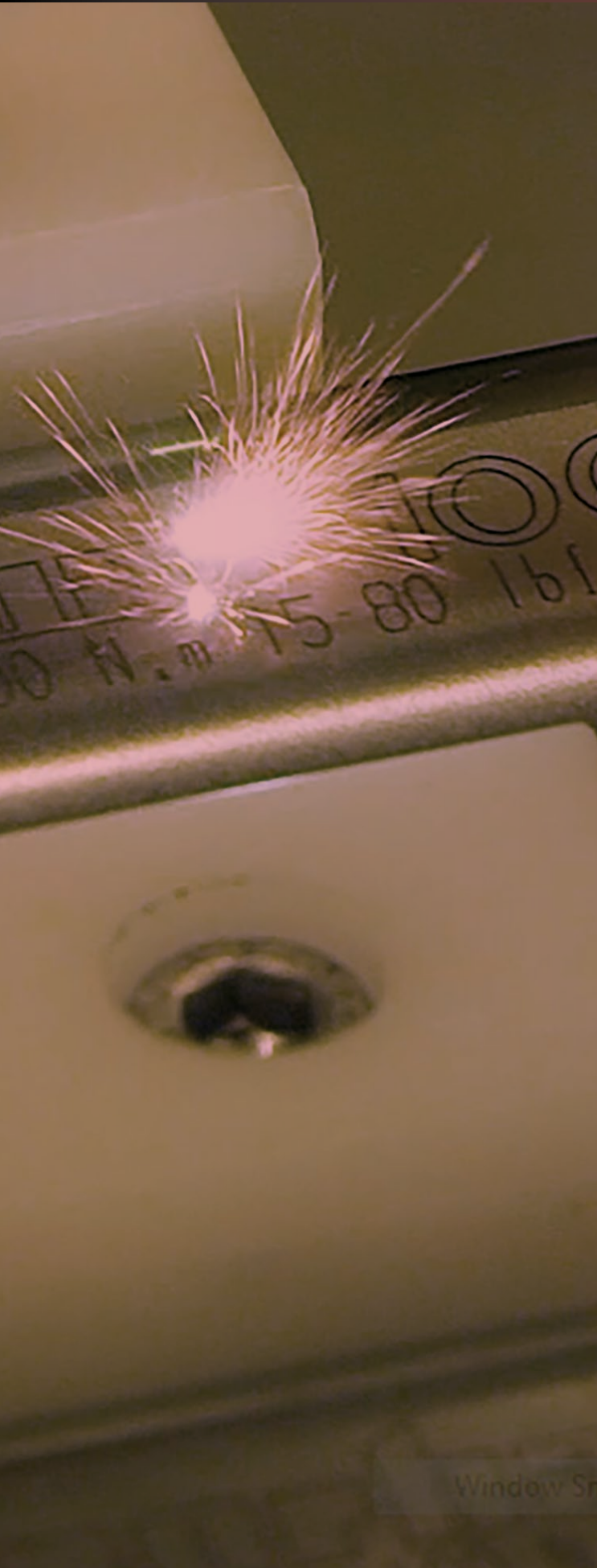

Tool Controllers 109

Norbar's Tool Controllers are used in a range of industries and applications where a high degree of tool control, automation or data gathering is required.

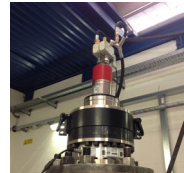

Valve Testing 111

Norbar's Valve Testing System has been designed to monitor and control the opening and closing of ball valves and gate valves



Harsh Environment 113

Norbar's HE range is the ideal choice whenever it is necessary to apply or measure torque outdoors or in potentially wet or dusty conditions



Engineer to Order 117

As an ISO 9001 accredited company, Norbar will undertake the design and manufacture of special equipment against agreed customer specifications

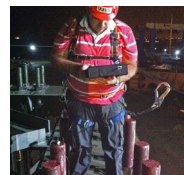

Ultrasonic Measurement 122

The Delta Sigma has been both laboratory and field-proven to be highly accurate, reliable and a cost-effective solution for eliminating bolting failures



Calibration Beams & Weights 125

Designed to remove potential sources of measurement error, these beams can be used to calibrate transducers and mechanical test devices



Spares Kits 130

In order to maintain the quality, performance and peace of mind associated with our products Norbar recommend that only genuine Norbar spares are fitted to our products



Calibration Services 135

Users of torque equipment all over the world are realising the importance of calibration in maintaining traceability and quality of operations. Norbar's UKAS accredited laboratory is one of the finest in the world



What is Torque?

Torque is any force or system of forces that tends to cause rotation about an axis.

Measurement of Torque

Imagine someone tightening a bolt using a socket attached to a meter (m) long bar. If they apply 10 kg of force (kgf) perpendicular to the bar they will produce a torque of 10 kgf·m at the axis (the centre of the bolt).

However, under the S.I. system of measurement, force is expressed in Newtons (N) rather than kgf. The conversion between kgf and N is x 9.807 so the person is applying 98.07 N·m of torque.

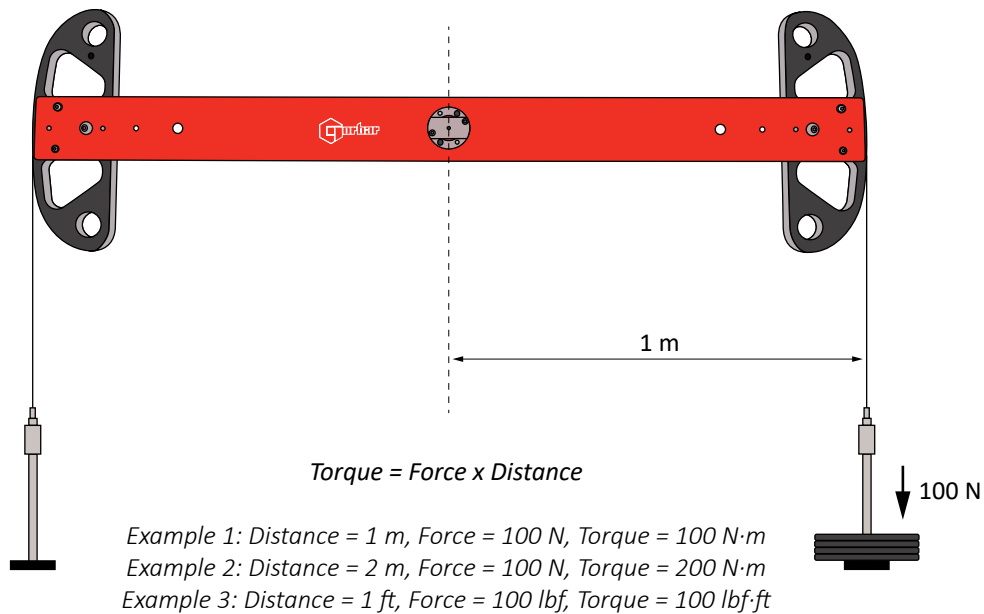

The Importance of Torque Control

Although many methods exist to join two or more parts together, the ease of assembly and disassembly provided by threaded fasteners make them the ideal choice for many applications.

The object of a threaded fastener is to clamp parts together with a tension greater than the external forces tending to separate them. The bolt then remains under constant stress and is immune from fatigue. However, if the initial tension is too low, varying loads act on the bolt and it will quickly fail. If the initial tension is too high, the tightening process may cause bolt failure. Reliability therefore depends upon correct initial tension. The most practical way of ensuring this is by specifying and controlling the tightening torque.

Bolt Tension

When an assembly is clamped by tightening a nut and bolt, the induced tension causes the bolt to stretch. An equal force acts to compress the parts which are thus clamped.

The proof load of a bolt, normally established by test, is the load which just starts to induce permanent set – also known as the yield point. Typically bolts are tightened to between 75% and 90% of yield.

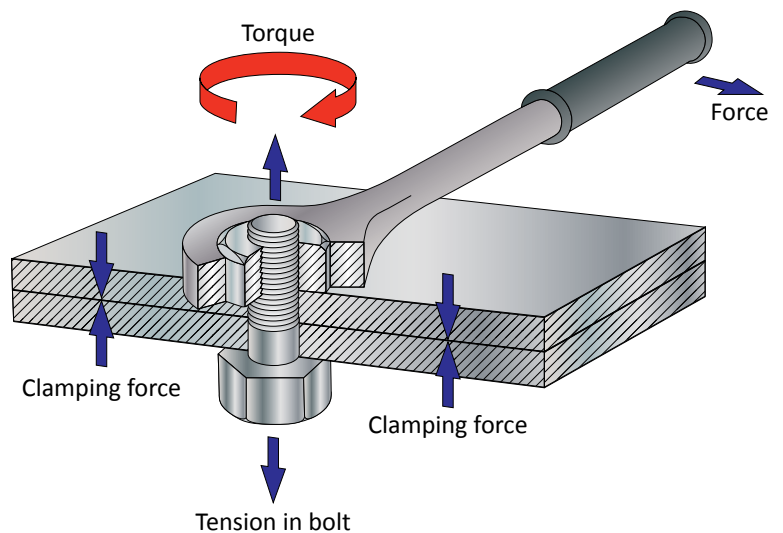



INTRODUCTION TO TORQUE

Friction in the Bolted Joint

When a threaded fastener is tightened, the induced tension results in friction under the head of the bolt and in the threads. It is generally accepted that as much as 50% of the applied torque is expended in overcoming friction between the bolt head and the abutting surface and another 30% to 40% is lost to friction in the threads. As little as 10% of the applied torque results in useful work to tension the bolt.

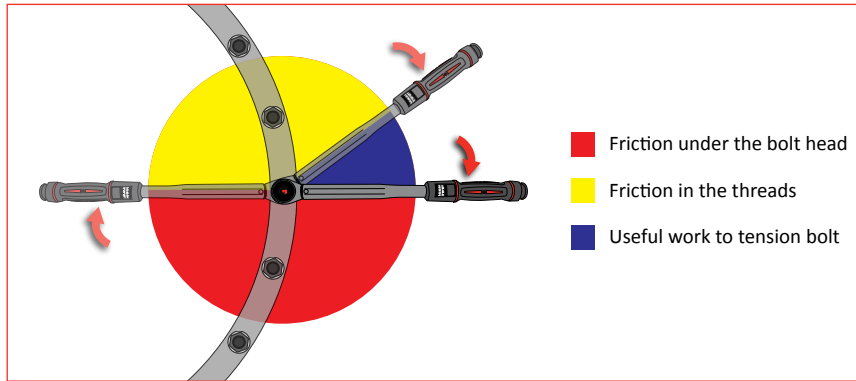

Given that up to 90% of the applied torque will be lost to friction, it follows that any changes in the coefficient of friction resulting from differences in surface finish, surface condition and lubrication can have a dramatic effect on the torque versus tension relationship. Some general points can be made:

- Most torque tightened joints do not use washers because their use can result in relative motion between the nut and washer or the washer and joint surface during tightening. This has the effect of changing the friction radius and hence affects the torque-tension relationship. Where a larger bearing face is required then flange nuts or bolts can be used. If washers are to be used, hard washers with a good fit to the shank of the bolt give lower and more consistent friction and are generally to be preferred.
- Degreasing fasteners of the film of oil usually present on them as supplied will decrease the tension for a given torque and may result in shear of the fastener before the desired tension is achieved.
- Super lubricants formulated from graphite, molybdenum disulphide and waxes result in minimal friction. Unless allowance is made in the specified tightening torque, the induced tension may be excessive causing the bolt to yield and fail. However, used in a controlled manner, these lubricants serve a useful purpose in reducing the torque to produce the desired tension meaning that a lower capacity tightening tool can be used.
- For reasons of appearance or corrosion resistance, fasteners may be plated. These treatments affect the coefficient of friction and therefore the torque versus tension relationship.
- Friction is often deliberately introduced into the fastener to reduce the possibility of loosening due to vibration. Devices such as lock-nuts must be taken into account when establishing the correct tightening torque.

As a rough guide, the calculated tightening torque should be multiplied by the factor from the table below according to surface treatment and lubrication.

| | | Surface Condition of Bolt | | | |
|--------------------------|-------------------|---------------------------|------|---------|-----------|
| | | Untreated | Zinc | Cadmium | Phosphate |
| Surface Condition of Nut | Untreated | 1.00 | 1.00 | 0.80 | 0.90 |
| | Zinc | 1.15 | 1.20 | 1.35 | 1.15 |
| | Cadmium | 0.85 | 0.90 | 1.20 | 1.00 |
| | Phosphate and oil | 0.70 | 0.65 | 0.70 | 0.75 |
| | Zinc with wax | 0.60 | 0.55 | 0.65 | 0.55 |



Tightening to Yield

Bolts tightened to yield provide consistently higher preloads from smaller diameter bolts. The reduced fastener stiffness reduces the fatigue loading to which the bolt is subjected under repeated external load reversals, e.g. cylinder heads and connecting rods.

In theory, a bolt tightened to its yield point will provide the strongest and most fatigue-resistant joint possible, within the physical limitations of the bolt material and manufacturing process.

The downside of this method is the cost of the sophisticated equipment necessary to determine when the bolt goes into yield.

Torque Tension Calculator

For further information and guidance on establishing the correct tightening torque for a fastener, see Norbar’s web based calculator, www.norbar.com/Support/Calculators/Torque-Tension-Calculator



| | | | | |
|---|--|--------------------------------|--|--|
| Calculated Maximum Torque | | Calculated Maximum Load | | |
| N.m.: 0.05 | | kN: 0.15 | | |
| lbf. ft.: 0.04 | | lbf: 34.7 | | |
| Bolt Properties | | | | |
| Bolt Diameter | <input type="text" value="1.6"/> | mm | | |
| Yield Stress | <input type="text" value="180"/> | N/mm ² | | |
| Pitch | <input type="text" value="0.35"/> | mm | | |
| Pitch Diameter | <input type="text" value="1.373"/> | mm | | |
| Root Diameter | <input type="text" value="1.171"/> | mm | | |
| Hex A/f Diameter | <input type="text" value="3.2"/> | mm | | |
| Standard Parameters | | | | |
| Bolt Type | Metric Coarse | | | |
| Bolt Dia. | 1.6 | | | |
| Grade | 3.6 | | | |
| Friction Coefficients | | | | |
| Thread | 0.14 | | | |
| Head | 0.14 <input type="button" value="Defaults"/> | | | |
| These torque and load values are for guidance only! Always check with equipment/bolt manufacturer | | | | |

When Torque Doesn't Equal Tight

As we have established, it is the tension in a fastener rather than the torque that is the critical factor. Torque is an indirect means of establishing tension and in a correctly engineered joint and with a controlled tightening process, it is a satisfactory method under the majority of circumstances.

However, in joints that are highly critical due to safety or the cost and implications of machine down-time, a more direct means of establishing tension is needed. Various methods exist including several types of load indicating bolts or washers. However, one of the most versatile methods is to measure the extension of the bolt due to the tightening process using ultrasound.

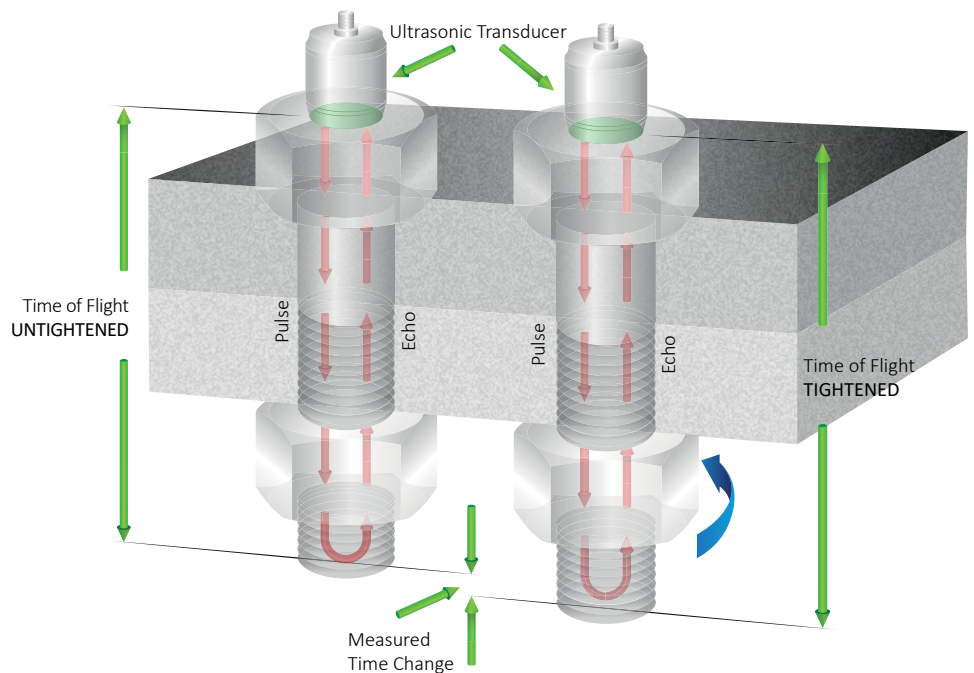





INTRODUCTION TO TORQUE

Recommended Maximum Torque Values

The information supplied here is intended to be an acceptable guide for normal conditions. For critical applications, further information and research will be necessary. The following basic assumptions have been made:

- Bolts are new, standard finish, uncoated and not lubricated (other than the normal protective oil film)
- The load will be 90% of the bolt yield strength
- The coefficient of friction is 0.14
- The final tightening sequence is achieved smoothly and slowly

If lubrication is to be applied to the nut/bolt, multiply the recommended torque by the appropriate factor shown in the table on page 9. Alternatively, use the Torque/Tension Calculator on the Norbar website (shown on page 10) which enables fastener and friction conditions to be modified with ease.

|  M | BOLT GRADE | | | | | | | | |  mm |
|--|---------------|-------|-------|--------|--------|--------|--------|--------|--------|---|
| | 3.6 | 4.6 | 5.6 | 5.8 | 6.8 | 8.8 | 9.8 | 10.9 | 12.9 | |
| | Torque in N·m | | | | | | | | | |
| M 1.6 | 0.05 | 0.07 | 0.09 | 0.11 | 0.14 | 0.18 | 0.21 | 0.26 | 0.31 | 3.2 |
| M 2 | 0.11 | 0.14 | 0.18 | 0.24 | 0.28 | 0.38 | 0.42 | 0.53 | 0.63 | 4 |
| M 2.5 | 0.22 | 0.29 | 0.36 | 0.48 | 0.58 | 0.78 | 0.87 | 1.09 | 1.31 | 5 |
| M 3 | 0.38 | 0.51 | 0.63 | 0.84 | 1.01 | 1.35 | 1.52 | 1.9 | 2.27 | 5.5 |
| M 4 | 0.71 | 0.95 | 1.19 | 1.59 | 1.91 | 2.54 | 2.86 | 3.57 | 4.29 | 7 |
| M 5 | 1.71 | 2.28 | 2.85 | 3.8 | 4.56 | 6.09 | 6.85 | 8.56 | 10.3 | 8 |
| M 6 | 2.94 | 3.92 | 4.91 | 6.54 | 7.85 | 10.5 | 11.8 | 14.7 | 17.7 | 10 |
| M 8 | 7.11 | 9.48 | 11.9 | 15.8 | 19 | 25.3 | 28.4 | 35.5 | 42.7 | 13 |
| M 10 | 14.3 | 19.1 | 23.8 | 31.8 | 38.1 | 50.8 | 57.2 | 71.5 | 85.8 | 17 |
| M 12 | 24.4 | 32.6 | 40.7 | 54.3 | 65.1 | 86.9 | 97.9 | 122 | 147 | 19 |
| M 14 | 39 | 52 | 65 | 86.6 | 104 | 139 | 156 | 195 | 234 | 22 |
| M 16 | 59.9 | 79.9 | 99.8 | 133 | 160 | 213 | 240 | 299 | 359 | 24 |
| M 18 | 82.5 | 110 | 138 | 183 | 220 | 293 | 330 | 413 | 495 | 27 |
| M 20 | 117 | 156 | 195 | 260 | 312 | 416 | 468 | 585 | 702 | 30 |
| M 22 | 158 | 211 | 264 | 352 | 422 | 563 | 634 | 792 | 950 | 32 |
| M 24 | 202 | 270 | 337 | 449 | 539 | 719 | 809 | 1,011 | 1,213 | 36 |
| M 27 | 298 | 398 | 497 | 663 | 795 | 1,060 | 1,193 | 1,491 | 1,789 | 41 |
| M 30 | 405 | 540 | 675 | 900 | 1,080 | 1,440 | 1,620 | 2,025 | 2,430 | 46 |
| M 33 | 550 | 734 | 917 | 1,223 | 1,467 | 1,956 | 2,201 | 2,751 | 3,301 | 50 |
| M 36 | 708 | 944 | 1,180 | 1,573 | 1,888 | 2,517 | 2,832 | 3,540 | 4,248 | 55 |
| M 39 | 919 | 1,226 | 1,532 | 2,043 | 2,452 | 3,269 | 3,678 | 4,597 | 5,517 | 60 |
| M 42 | 1,139 | 1,518 | 1,898 | 2,530 | 3,036 | 4,049 | 4,555 | 5,693 | 6,832 | 65 |
| M 45 | 1,425 | 1,900 | 2,375 | 3,167 | 3,800 | 5,067 | 5,701 | 7,126 | 8,551 | 70 |
| M 48 | 1,716 | 2,288 | 2,860 | 3,813 | 4,576 | 6,101 | 6,864 | 8,580 | 10,296 | 75 |
| M 52 | 2,210 | 2,947 | 3,684 | 4,912 | 5,895 | 7,859 | 8,842 | 11,052 | 13,263 | 80 |
| M 56 | 2,737 | 3,650 | 4,562 | 6,083 | 7,300 | 9,733 | 10,950 | 13,687 | 16,425 | 85 |
| M 60 | 3,404 | 4,538 | 5,673 | 7,564 | 9,076 | 12,102 | 13,614 | 17,018 | 20,422 | 90 |
| M 64 | 4,100 | 5,466 | 6,833 | 9,110 | 10,932 | 14,576 | 16,398 | 20,498 | 24,597 | 95 |
| M 68 | 4,963 | 6,617 | 8,271 | 11,029 | 13,234 | 17,646 | 19,851 | 24,814 | 29,777 | 100 |



INTRODUCTION TO TORQUE

Torque Conversion Factors

| Units to be converted | S.I. Units | | Imperial Units | | | Metric Units | |
|-----------------------|------------|-------|----------------|--------|--------|--------------|--------|
| | cN·m | N·m | ozf·in | lbf·in | lbf·ft | kgf·cm | kgf·m |
| 1 cN·m = | 1 | 0.01 | 1.416 | 0.088 | 0.007 | 0.102 | 0.001 |
| 1 N·m = | 100 | 1 | 141.6 | 8.851 | 0.738 | 10.20 | 0.102 |
| 1 ozf·in = | 0.706 | 0.007 | 1 | 0.0625 | 0.005 | 0.072 | 0.0007 |
| 1 lbf·in = | 11.3 | 0.113 | 16 | 1 | 0.083 | 1.152 | 0.0115 |
| 1 lbf·ft = | 135.6 | 1.356 | 192 | 12 | 1 | 13.83 | 0.138 |
| 1 kgf·cm = | 9.807 | 0.098 | 13.89 | 0.868 | 0.072 | 1 | 0.01 |
| 1 kgf·m = | 980.7 | 9.807 | 1389 | 86.8 | 7.233 | 100 | 1 |

FORCE

$$\text{lbf} \times 4.45 = \text{N}$$

$$\text{N} \times 0.225 = \text{lbf}$$

FLOW

$$\text{l/s} \times 2.119 = \text{cu·ft/min}$$

$$\text{cu·ft/min} \times 0.472 = \text{l/s}$$

PRESSURE

$$\text{lbf/in}^2 \times 0.069 = \text{bar}$$

$$\text{bar} \times 14.504 = \text{lbf/in}^2$$

POWER

$$\text{hp} \times 0.746 = \text{kW}$$

$$\text{kW} = \frac{\text{N·m} \times \text{rev/min}}{9,546}$$

Formulae

Accepted formulae relating torque and tension, based on many tests are:-

For Imperial Sizes

$$M = \frac{P \times D}{60}$$

M = torque lbf·ft
P = bolt tension lbf
D = bolt diameter (ins)

For Metric Sizes

$$M = \frac{P \times D}{5000}$$

M = torque N·m
P = bolt tension Newtons
D = bolt diameter (mm)

These formulae may be used for bolts outside the range of the tables.

Formula for Calculating the Effect of Torque Wrench Extensions

$$M1 = M2 \times L1/L2$$

Where L1 is the normal length and L2 is the extended length, M1 is the set torque and M2 the actual torque applied to the nut.

Example

The required torque on the fastener is 130 N·m (M2) but what do you set on the torque wrench scale?

$$L1 = 500 \quad L2 = 650$$

(units of length not important, this is ratio)

$$M1 = 130 \times 500/650$$

$$M1 = 100$$

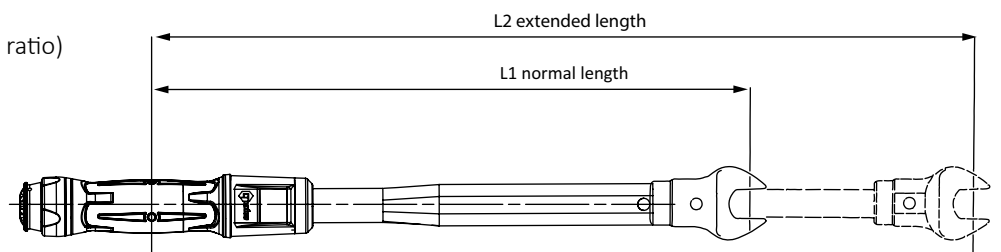

For further information and guidance on converting torque and calculating the effect of torque wrench extensions download our purpose-built applications for iPhone and Android.



TORQUE SCREWDRIVERS AND TORQUE WRENCHES



Torque Screwdrivers 14

Professional Torque Wrenches Model 5 14

Slimline™ Torque Wrenches 15

TT Torque Wrenches 16

TTi Non-Magnetic Torque Wrenches 16

Insulated Torque Wrenches 17

NorTorque® Tethered Torque Wrenches - for working at height 17

NorTorque® 18

Professional 'P' Type Torque Wrenches 20

Professional Torque Wrenches 22

XR Pro Torque Wrenches 26

Industrial Torque Wrenches Adjustable & 'P' Type - New Generation 28

Industrial Torque Wrench - Bi-Square 30

Electrode Wrenches 30

UKAS Accredited Calibration Certification 30

Norbar Torque Tools manufacture an extensive range of high quality torque screwdrivers and torque wrenches to cover torque values from 0.3 N·m to 2,000 N·m. They are designed and manufactured to exceed international standards for accuracy.

In addition to the normal 'adjustable' torque wrenches, Norbar offer Production 'P' Type versions which can be pre-set and dedicated to a particular application. This setting system is designed to discourage unauthorised alteration.



TORQUE SCREWDRIVERS



Versatile, accurate and easy torquing for smaller fasteners and restricted spaces

- Accuracy to ±6% meets the requirements of ISO 6789-1:2017
- Supplied with ¼" hexagon bit holder
- Single scale, either N·m or lbf·in

NOTE: Bit set is only sold separately or as part of kit - see website for bit set details

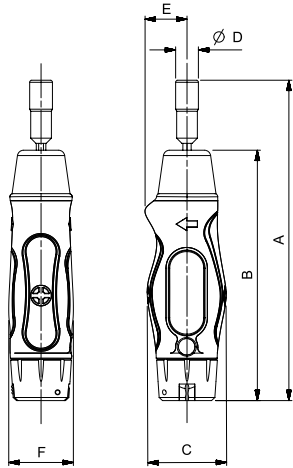

| MODEL | ALL MODELS | |
|-----------------|------------|-----|
| Dimensions (mm) | A | 155 |
| | B | 121 |
| | C | 38 |
| | ∅D | 11 |
| | E | 20 |
| | F | 31 |
| Weight (kg) | 0.2 | |

| 2 | ADJUSTABLE N·m |
|-------|---------------------------|
| 13850 | TTs1.5, ¼", 0.3 - 1.5 N·m |
| 13851 | TTs3.0, ¼", 0.6 - 3 N·m |
| 13852 | TTs6.0, ¼", 1.2 - 6 N·m |

| 2 | ADJUSTABLE lbf·in |
|-------|----------------------------|
| 13853 | TTs13, ¼", 2.5 - 13 lbf·in |
| 13854 | TTs26, ¼", 5 - 26 lbf·in |
| 13855 | TTs53, ¼", 10 - 53 lbf·in |

| 2 | PRODUCTION 'P' TYPE |
|--------|--|
| 13856 | TTs1.5, ¼", 0.3 - 1.5 N·m, 2.5 - 13 lbf·in |
| 13857 | TTs3.0, ¼", 0.6 - 3 N·m, 5 - 26 lbf·in |
| 13858 | TTs6.0, ¼", 1.2 - 6 N·m, 10 - 53 lbf·in |
| SQ2222 | Pre-set, etch and certify (Allow 3 days delivery for this service) |

| 2 | ADJUSTABLE N·m KIT |
|-------|---|
| 13700 | TTs0.3 - 1.5 N·m Kit with 12 piece bit set and case |
| 13701 | TTs0.6 - 3 N·m Kit with 12 piece bit set and case |
| 13702 | TTs1.2 - 6 N·m Kit with 12 piece bit set and case |
| 28937 | 12 Piece ¼", Hex bit set |

PROFESSIONAL TORQUE WRENCHES MODEL 5



The Model 5 is a unique torque wrench that offers the convenience of interchangeable ¼" hexagon bits. (ISO 1173:2001 Form C drive bits).

- Accuracy meets the requirements of ISO 6789-1:2017
- Non-length dependent. The Model 5 remains accurate regardless of hand position
- Supplied in a storage case. The case allows space for the storage of additional drive bits

| 2 | ADJUSTABLE |
|-------|--------------------------------------|
| 13001 | Pro 5, ¼" female hex, 1 - 5 N·m |
| 13002 | Pro 5, ¼" female hex, 10 - 50 lbf·in |
| 13003 | Pro 5, ¼" female hex, 10 - 50 kgf·cm |

Also available as Production 'P' Types, preventing unauthorised alteration of torque setting. No external calibration equipment is required to set the Model 5 'P' Type.

| 2 | PRODUCTION 'P' TYPE |
|-------|--------------------------------------|
| 13004 | Pro 5, ¼" female hex, 1 - 5 N·m |
| 13005 | Pro 5, ¼" female hex, 10 - 50 lbf·in |
| 13006 | Pro 5, ¼" female hex, 10 - 50 kgf·cm |

| 8 | MODEL 5 SPARES |
|-------|--------------------------------|
| 28900 | ¼" Hex to ¼" male square drive |

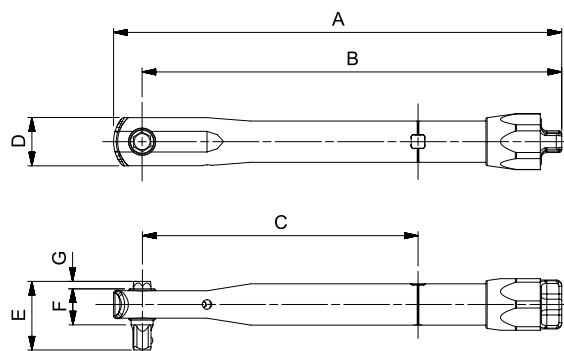

Model 5 'P' Type in storage case

| Model | Adjustable | 'P' Type |
|-----------------|------------|----------|
| Part Number | 13001 | 13004 |
| | 13002 | 13005 |
| | 13003 | 13006 |
| Dimensions (mm) | A | 165 |
| | B | 155 |
| | C | 102 |
| | D | 18 |
| | E | 25 |
| | F | 13 |
| | G | 2.8 |
| Weight (kg) | 0.1 | 0.1 |



SLIMLINE™ TORQUE WRENCHES



- Accurate to ±3% of reading which meets the requirements of ISO 6789-1:2017
- Unmistakable signal when set torque is reached
- High quality 72 tooth ratchet allows use in confined spaces
- Fixed head version has a push-through square for left and right handed torque tightening
- Moulded grip aids correct hand location and operator comfort

| 2 | ADJUSTABLE RATCHET - DUAL SCALE |
|-------|--------------------------------------|
| 11123 | SLO, ¼", 4 - 20 N·m, 40 - 180 lbf·in |
| 11087 | SLO, ⅜", 4 - 20 N·m, 40 - 180 lbf·in |



| 2 | ADJUSTABLE - FIXED HEAD - DUAL SCALE |
|-------|---|
| 11125 | SLO, ⅜" fixed head, 4 - 20 N·m, 40 - 180 lbf·in |

SLO Ratchet

| Model | SLO ¼" | SLO ⅜" |
|-----------------|----------------|----------------|
| Part Number | 11123 11085 | 11087 11086 |
| Dimensions (mm) | A | 219 |
| | B | 204 |
| | C | 146 |
| | ∅D | 30 |
| | E | 26 |
| | F | 19 |
| Weight (kg) | 0.4 | 0.4 |

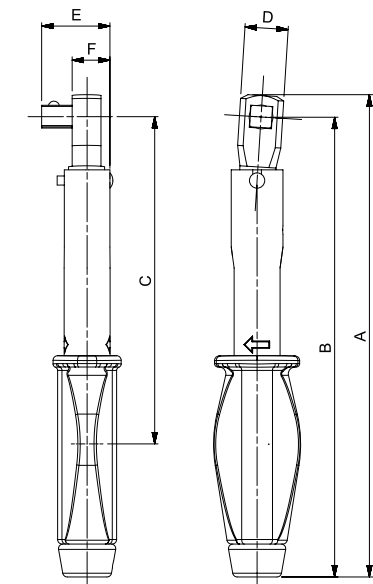
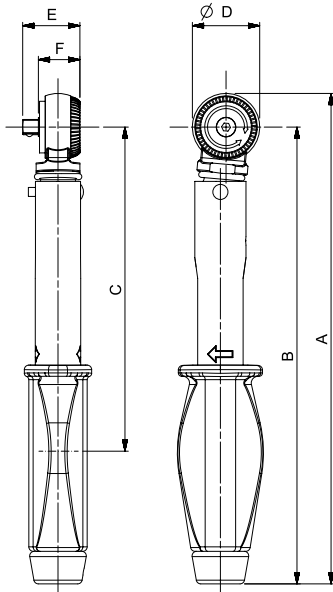

SLO Fixed Head

| Model | SLO ⅜" Fixed Head | |
|-----------------|-------------------|-----|
| Part Number | 11125 11089 | |
| Dimensions (mm) | A | 213 |
| | B | 203 |
| | C | 145 |
| | D | 19 |
| | E | 30 |
| | F | 17 |
| Weight (kg) | 0.4 | |



| 2 | TORQUE HANDLE ADJUSTABLE - DUAL SCALE |
|-------|---|
| 11126 | SLO 16 mm spigot, 4 - 20 N·m, 40 - 180 lbf·in |
| 11122 | SLO 9 x 12 mm female, 4 - 20 N·m, 40 - 180 lbf·in |

Production 'P' type versions are designed to discourage unauthorised alteration. They have no scale and so must be set against a torque measuring device such as Norbar's TruCheck™ 2 - see page 81.



| 2 | PRODUCTION 'P' TYPE (Must be set using a Torque Tester, see pages 81-88) |
|--------|---|
| 11089 | SLO, ⅜" fixed head, 4 - 20 N·m, 40 - 180 lbf·in |
| 11085 | SLO, ¼", 4 - 20 N·m, 40 - 180 lbf·in |
| 11086 | SLO, ⅜", 4 - 20 N·m, 40 - 180 lbf·in |
| 11090 | SLO, 16 mm spigot, 4 - 20 N·m, 40 - 180 lbf·in |
| 11088 | SLO, 9 x 12 mm female, 4 - 20 N·m, 40 - 180 lbf·in |
| SQ2222 | Pre-set, etch and certify (Allow 3 days delivery for this service) |

SLO Female Torque Handle

| Model | SLO FTH | |
|-----------------|----------------|-----|
| Part Number | 11122 11088 | |
| Dimensions (mm) | A | 205 |
| | B | 194 |
| | C | 135 |
| | D | 22 |
| | E | 20 |
| Weight (kg) | 0.4 | |

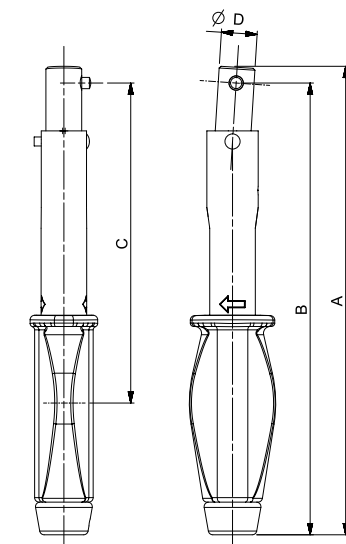
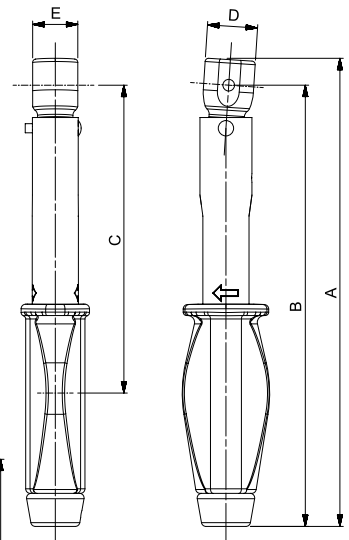

SLO Spigot Torque Handle

| Model | SLO Spigot | |
|-----------------|----------------|-----|
| Part Number | 11126 11090 | |
| Dimensions (mm) | A | 206 |
| | B | 199 |
| | C | 143 |
| | ∅D | 16 |
| Weight (kg) | 0.4 | |



TT TORQUE WRENCHES



For no-nonsense torquing - comfortable, accurate and easy to use

- Accurate to $\pm 3\%$ of reading which meets the requirements of ISO 6789-1:2017
- Micrometer scale for simple and error free setting
- All models feature a lock to prevent accidental adjustment of the set torque
- Handle and lens materials resistant to commonly used industrial chemicals



| Model | TT Torque Wrenches / Non-Magnetic | | | | |
|-----------------|--|--|--------------|--------------|-----|
| | TTi20 TTi15 | TTi50 TTi35 | TTfth20 | TTfth50 | |
| Part Number | 13830, 13831, 13832, 13833, 13900, 13901, 130503, 130504 | 13841, 13842, 13843, 13844, 13902, 13903, 13906, 13907 | 13839, 13840 | 13847, 13848 | |
| Dimensions (mm) | A | 232 | 328 | 214 | 310 |
| | B | 217 | 313 | 204 | 300 |
| | C | 166 | 263 | 153 | 250 |
| | ØD | 30 | 30 | 22 | 22 |
| | E | 31 | 31 | 17 | 17 |
| | F | 20 | 20 | N/A | N/A |
| Weight (kg) | 0.5 | 0.7 | 0.4 | 0.6 | |

| 2 | RATCHET ADJUSTABLE - DUAL SCALE |
|-------|--|
| 13830 | TTi20, ¼", 4 - 20 N·m, 35 - 180 lbf·in |
| 13831 | TTi20, ⅜", 4 - 20 N·m, 35 - 180 lbf·in |
| 13841 | TTi50, ⅜", 10 - 50 N·m, 8 - 35 lbf·ft |
| 13842 | TTi50, ½", 10 - 50 N·m, 8 - 35 lbf·ft |

| 2 | RATCHET ADJUSTABLE - N·m ONLY |
|-------|-------------------------------|
| 13832 | TTi20, ¼", 4 - 20 N·m |
| 13833 | TTi20, ⅜", 4 - 20 N·m |
| 13843 | TTi50, ⅜", 10 - 50 N·m |
| 13844 | TTi50, ½", 10 - 50 N·m |

| 2 | FEMALE TORQUE HANDLE ADJUSTABLE |
|-------|--|
| 13839 | TTfth 20, 9 x 12 mm, 4 - 20 N·m, 35 - 180 lbf·in |
| 13847 | TTfth 50, 9 x 12 mm, 10 - 50 N·m, 8 - 35 lbf·ft |
| 13840 | TTfth 20, 9 x 12 mm, 4 - 20 N·m (N·m ONLY) |
| 13848 | TTfth 50, 9 x 12 mm, 10 - 50 N·m (N·m ONLY) |

TTi Ratchet / Non-Magnetic

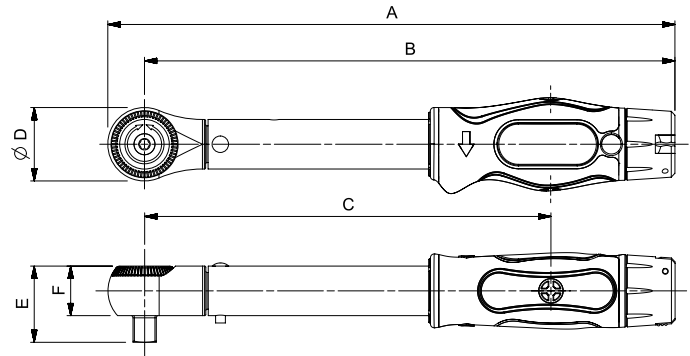

TTfth Female Torque Handle

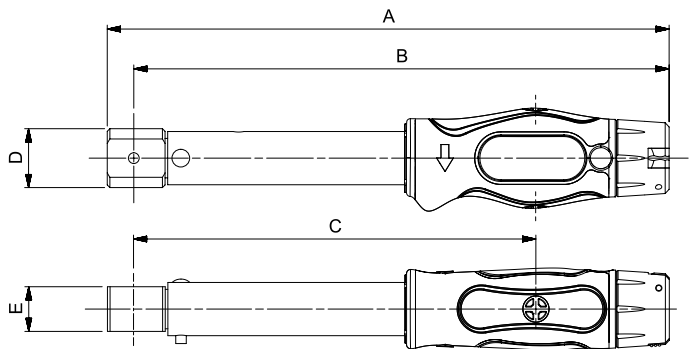

TTI NON-MAGNETIC TORQUE WRENCHES



Carefully selected and tested materials replace the ferrous components present in standard torque wrenches, thereby giving an extremely low magnetic footprint. Being based on the TT range of torque wrenches means that they also retain the high standards of Norbar's other torque wrenches. Perfect for MRI scanner applications.

| 4 | ADJUSTABLE - DUAL SCALE |
|-------|--|
| 13900 | TTi20, ⅜" Non-Mag, 4 - 20 N·m, 35 - 180 lbf·in |
| 13901 | TTi20, ½" Non-Mag, 4 - 20 N·m, 35 - 180 lbf·in |
| 13902 | TTi50, ⅜" Non-Mag, 10 - 50 N·m, 8 - 35 lbf·ft |
| 13903 | TTi50, ½" Non-Mag, 10 - 50 N·m, 8 - 35 lbf·ft |

| 4 | ADJUSTABLE - N·m ONLY |
|--------|--------------------------------|
| 130503 | TTi20, ⅜" Non-Mag, 4 - 20 N·m |
| 130504 | TTi20, ½" Non-Mag, 4 - 20 N·m |
| 13906 | TTi50, ⅜" Non-Mag, 10 - 50 N·m |
| 13907 | TTi50, ½" Non-Mag, 10 - 50 N·m |



INSULATED TORQUE WRENCHES



Fully insulated high precision torque wrench, IEC 60900:2018 compliant, for working on live or close to live parts at nominal voltages up to 1,000 V AC and 1,500 V DC

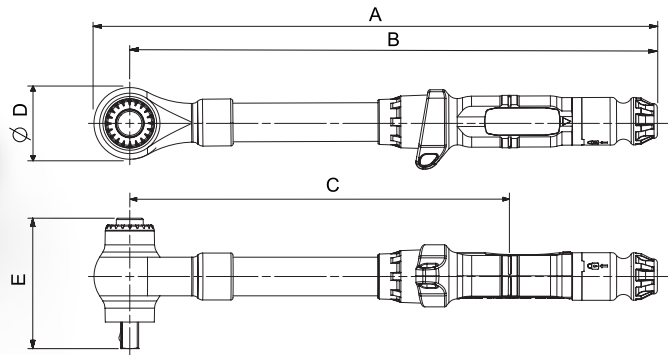

| 2 | ADJUSTABLE - DUAL SCALE |
|--------|--|
| 130537 | 20, 3/8", 4 - 20 N·m, 3 - 15 lbf·ft |
| 130505 | 50, 3/8", 10 - 50 N·m, 7.5 - 37.5 lbf·ft |
| 130506 | 50, 1/2", 10 - 50 N·m, 7.5 - 37.5 lbf·ft |
| 130507 | 100, 3/8", 20 - 100 N·m, 15 - 75 lbf·ft |
| 130508 | 100, 1/2", 20 - 100 N·m, 15 - 75 lbf·ft |
| 130509 | 200, 1/2", 40 - 200 N·m, 30 - 150 lbf·ft |

| Model | Insulated Torque Wrenches | | | | | |
|-----------------|---------------------------|------------------|------------------|-------------------|-------------------|-----------|
| | Model 20 | Model 50 3/8" | Model 50 1/2" | Model 100 3/8" | Model 100 1/2" | Model 200 |
| Part Number | 130537 | 130505 | 130506 | 130507 | 130508 | 130509 |
| Dimensions (mm) | A | 294 | 365 | 369 | 404 | 491 |
| | B | 272 | 343 | 343 | 382 | 465 |
| | C | 164.5 | 236 | 235 | 275 | 357 |
| | ØD | 44 | 44 | 52 | 44 | 52 |
| | E | 80 | 80 | 92 | 80 | 92 |
| Weight (kg) | 0.7 | 0.8 | 0.8 | 1 | 1 | 1.4 |

NORTORQUE® TETHERED TORQUE WRENCHES - FOR WORKING AT HEIGHT



| 2 | RATCHET ADJUSTABLE - DUAL SCALE |
|--------|--|
| 130178 | Model 100, 1/2", 20 - 100 N·m, 20 - 80 lbf·ft |
| 130179 | Model 200, 1/2", 40 - 200 N·m, 30 - 150 lbf·ft |

Features inbuilt tethering point to secure the tool for safe work at height and double-sided locking plunger square

- Pinned head in line with DROPS recommendation for ultra safe handling of sockets when working at height
- Built on a trusted, versatile torque wrench design
- Accurate to ±3% of reading which meets the requirements of ISO 6789-1:2017
- Light and fast adjustment saves operator time and effort
- Micrometer scale for simple and error free setting
- Lock feature helps prevent accidental adjustment of the set torque
- Convenient hanger feature for tool storage also aids wrench unlocking and adjustment

| Model | NorTorque Tethered Torque Wrenches | |
|-----------------|------------------------------------|-----------|
| | Model 100 | Model 200 |
| Part Number | 130178 | 130179 |
| Dimensions (mm) | A | 375 |
| | B | 354 |
| | C | 252 |
| | ØD | 42 |
| | E | 53 |
| | F | 22 |
| | G | 16 |
| Weight (kg) | 0.9 | 1.1 |

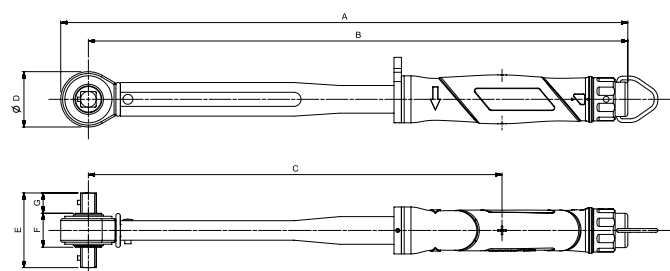



NORTORQUE®



The NorTorque® utilises Norbar's proven mechanism and internal components and incorporates them into a purposeful and attractive torque wrench that will delight a wide range of users from professional mechanics to hobby enthusiasts

- Accurate to $\pm 3\%$ of reading which meets the requirements of ISO 6789-1:2017
- Light and fast adjustment saves operator time and effort
- Micrometer scale applying to the primary torque units (N·m on a dual scale wrench) for simple and error-free setting
- 'Push-through' ratchets allow torque control in both the clockwise and counter-clockwise directions
- Tough ratchets with narrow engagement angles allow for easy positioning of the tool in confined spaces (5° for models up to 200 N·m and 6° for models 300 N·m and above)
- Push/pull lock is fast and intuitive to use and prevents accidental adjustment of the set torque
- Convenient hanger feature for tool storage also aids wrench unlocking and adjustment
- Tethered versions are available for working at height (see page 17)



Left to Right: Torque Handle, Ratchet & Female Torque Handle

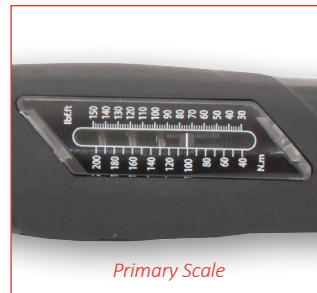

Primary Scale

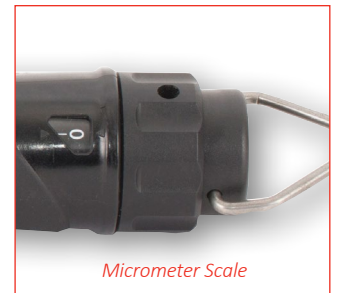

Micrometer Scale

On dual scale wrenches, the micrometer scale refers to the N·m value only



NORTORQUE®



| 2 RATCHET ADJUSTABLE - DUAL SCALE | |
|-----------------------------------|--|
| 130101* | Model 60, 3/8", 12 - 60 N·m, 10 - 45 lbf·ft |
| 130103 | Model 100, 1/2", 20 - 100 N·m, 20 - 80 lbf·ft |
| 130104 | Model 200, 1/2", 40 - 200 N·m, 30 - 150 lbf·ft |
| 130105 | Model 300, 1/2", 60 - 300 N·m, 45 - 220 lbf·ft |
| 130106 | Model 340, 1/2", 60 - 340 N·m, 45 - 250 lbf·ft |

* Supplied with 1/2" sq. dr. adaptor
 · Supplied with 3/8" sq. dr. adaptor

| 2 TORQUE HANDLE ADJUSTABLE 16 mm SPIGOT - DUAL SCALE | |
|--|--|
| 130141 | Model 60, 16 mm spigot, 12 - 60 N·m, 10 - 45 lbf·ft |
| 130142 | Model 100, 16 mm spigot, 20 - 100 N·m, 20 - 80 lbf·ft |
| 130143 | Model 200, 16 mm spigot, 40 - 200 N·m, 30 - 150 lbf·ft |
| 130144 | Model 300, 16 mm spigot, 60 - 300 N·m, 45 - 220 lbf·ft |

Ratchet Adjustable

| Model | NorTorque 60 | NorTorque 100 | NorTorque 200 | NorTorque 300 | NorTorque 340 | |
|-----------------|--------------|---------------|---------------|---------------|---------------|-----|
| Part Number | 130101 | 130103 | 130104 | 130105 | 130106 | |
| Dimensions (mm) | A | 328 | 375 | 459 | 587 | 679 |
| | B | 310 | 354 | 437 | 562 | 654 |
| | C | 209 | 252 | 335 | 460 | 552 |
| | ØD | 36 | 42 | 45 | 52 | 52 |
| | E | 34 | 38 | 45 | 45 | 45 |
| | F | 21 | 22 | 25 | 25 | 25 |
| Weight (kg) | 0.7 | 0.8 | 1.0 | 1.4 | 1.6 | |

Female Torque Handle Adjustable

| Model | NorTorque 60 9 x 12 mm | NorTorque 100 9 x 12 mm | NorTorque 200 9 x 12 mm | NorTorque 200 14 x 18 mm | NorTorque 300 14 x 18 mm | NorTorque 340 14 x 18 mm | |
|-----------------|---------------------------|----------------------------|----------------------------|-----------------------------|-----------------------------|-----------------------------|-----|
| Part Number | 130121 | 130123 | 130125 | 130126 | 130127 | 130128 | |
| Dimensions (mm) | A | 319 | 360 | 437 | 446 | 566 | 658 |
| | B | 308 | 348 | 426 | 430 | 550 | 642 |
| | C | 206 | 247 | 324 | 329 | 448 | 540 |
| | D | 22 | 22 | 24 | 33 | 36 | 36 |
| | E | 20 | 20 | 20 | 25 | 28 | 28 |
| Weight (kg) | 0.6 | 0.7 | 0.8 | 0.9 | 1.2 | 1.3 | |

Torque Handle Adjustable 16 mm Spigot

| Model | NorTorque 60 | NorTorque 100 | NorTorque 200 | NorTorque 300 | |
|-----------------|--------------|---------------|---------------|---------------|-----|
| Part Number | 130141 | 130142 | 130143 | 130144 | |
| Dimensions (mm) | A | 317 | 357 | 439 | 564 |
| | B | 310 | 350 | 433 | 557 |
| | C | 208 | 248 | 331 | 455 |
| | ØD | 16 | 16 | 16 | 16 |
| Weight (kg) | 0.6 | 0.7 | 0.8 | 1.1 | |

| 2 FEMALE TORQUE HANDLE ADJUSTABLE - DUAL SCALE | |
|--|--|
| 130121 | Model 60, 9 x 12 mm, 12 - 60 N·m, 10 - 45 lbf·ft |
| 130123 | Model 100, 9 x 12 mm, 20 - 100 N·m, 20 - 80 lbf·ft |
| 130125 | Model 200, 9 x 12 mm, 40 - 200 N·m, 30 - 150 lbf·ft |
| 130126 | Model 200, 14 x 18 mm, 40 - 200 N·m, 30 - 150 lbf·ft |
| 130127 | Model 300, 14 x 18 mm, 60 - 300 N·m, 45 - 220 lbf·ft |
| 130128 | Model 340, 14 x 18 mm, 60 - 340 N·m, 45 - 250 lbf·ft |

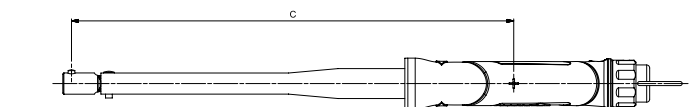
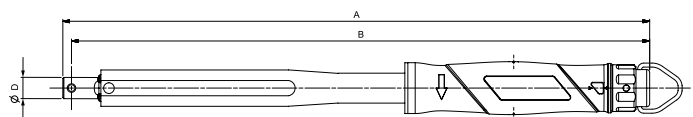
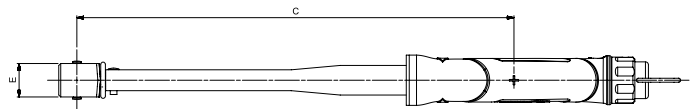
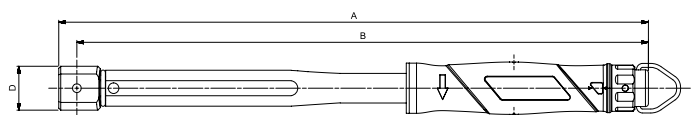
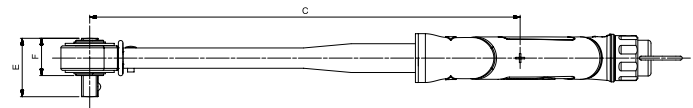
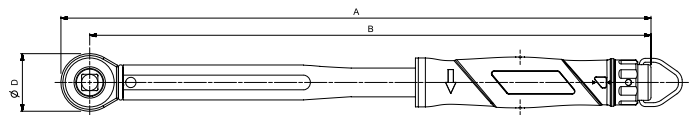



PROFESSIONAL 'P' TYPE TORQUE WRENCHES



For production line applications requiring a sealed torque setting, 'P' Type wrenches have no scale and must be set against a suitable torque measuring device (see pages 81-88).

- Accurate to ±3% of reading which meets the requirements of ISO 6789-1:2017
- Colour-coded adjustment seals and locking tool provided
- On request 'P' Type wrenches can be set, marked with the setting and certified for production line applications requiring a sealed torque setting. Only if a pre-set has been requested will the tool be supplied with a Declaration of Conformance



Colour-coded adjustment seals



- Push-through ratchet allows clockwise and counter-clockwise torque control

| 2 | PRODUCTION 'P' TYPE - INDUSTRIAL RATCHET (Push-through square) |
|--------|--|
| 13051 | Pro 60, 3/8", 12 - 60 N·m, 5 - 45 lbf-ft |
| 13052 | Pro 60, 1/2", 12 - 60 N·m, 5 - 45 lbf-ft |
| 13053 | Pro 100, 3/8", 20 - 100 N·m, 15 - 75 lbf-ft |
| 13054 | Pro 100, 1/2", 20 - 100 N·m, 15 - 75 lbf-ft |
| 13055 | Pro 200, 1/2", 40 - 200 N·m, 30 - 150 lbf-ft |
| 13057 | Pro 300, 1/2", 60 - 300 N·m, 45 - 220 lbf-ft |
| 13056 | Pro 400, 3/4", 80 - 400 N·m, 60 - 300 lbf-ft |
| 11698 | Calibration Kit Professional 'P' Type |
| SQ2222 | Pre-set, etch and certify (Allow 3 days delivery for this service) |

| 2 | TORQUE HANDLE PRODUCTION 'P' TYPE 16 mm SPIGOT |
|--------|--|
| 11167 | Pro 60, 16 mm spigot, 12 - 60 N·m, 5 - 45 lbf-ft |
| 11143 | Pro 100, 16 mm spigot, 20 - 100 N·m, 15 - 75 lbf-ft |
| 11144 | Pro 200, 16 mm spigot, 40 - 200 N·m, 30 - 150 lbf-ft |
| 11117 | Pro 300, 16 mm spigot, 60 - 300 N·m, 45 - 220 lbf-ft |
| SQ2222 | Pre-set, etch and certify (Allow 3 days delivery for this service) |



- Reversible, 72 tooth ratchet

| 2 | PRODUCTION 'P' TYPE AUTOMOTIVE RATCHET (Reversible) |
|--------|--|
| 11164 | Pro 60, 3/8", 12 - 60 N·m, 5 - 45 lbf-ft |
| 11171 | Pro 60, 1/2", 12 - 60 N·m, 5 - 45 lbf-ft |
| 11138 | Pro 100, 3/8", 20 - 100 N·m, 15 - 75 lbf-ft |
| 11139 | Pro 100, 1/2", 20 - 100 N·m, 15 - 75 lbf-ft |
| 11140 | Pro 200, 1/2", 40 - 200 N·m, 30 - 150 lbf-ft |
| SQ2222 | Pre-set, etch and certify (Allow 3 days delivery for this service) |

| 2 | FEMALE TORQUE HANDLE PRODUCTION 'P' TYPE |
|--------|--|
| 11170 | Pro 60, 9 x 12 mm, 12 - 60 N·m, 5 - 45 lbf-ft |
| 11150 | Pro 100, 9 x 12 mm, 20 - 100 N·m, 15 - 75 lbf-ft |
| 11151 | Pro 200, 9 x 12 mm, 40 - 200 N·m, 30 - 150 lbf-ft |
| 11152 | Pro 200, 14 x 18 mm, 40 - 200 N·m, 30 - 150 lbf-ft |
| 11153 | Pro 300, 14 x 18 mm, 60 - 300 N·m, 45 - 220 lbf-ft |
| 13068 | Pro 400, 14 x 18 mm, 80 - 400 N·m, 60 - 300 lbf-ft |
| SQ2222 | Pre-set, etch and certify (Allow 3 days delivery for this service) |



PROFESSIONAL 'P' TYPE TORQUE WRENCHES



Industrial Ratchet

| Model | Pro 60, 3/8" | Pro 60, 1/2" | Pro 100, 3/8" | Pro 100, 1/2" | Pro 200 | Pro 300 | Pro 400 |
|-----------------|--------------|--------------|---------------|---------------|---------|---------|---------|
| Part Number | 13051 | 13052 | 13053 | 13054 | 13055 | 13057 | 13056 |
| Dimensions (mm) | A | 295 | 301 | 335 | 342 | 425 | 668 |
| | B | 277 | 281 | 317 | 321 | 403 | 641 |
| | C | 212 | 216 | 252 | 256 | 338 | 577 |
| | ∅D | 36 | 42 | 36 | 42 | 45 | 54 |
| | E | 34 | 38 | 34 | 38 | 46 | 46 |
| | F | 21 | 23 | 21 | 22 | 29 | 29 |
| Weight (kg) | 0.6 | 0.7 | 0.7 | 0.7 | 1.0 | 1.2 | 2.0 |

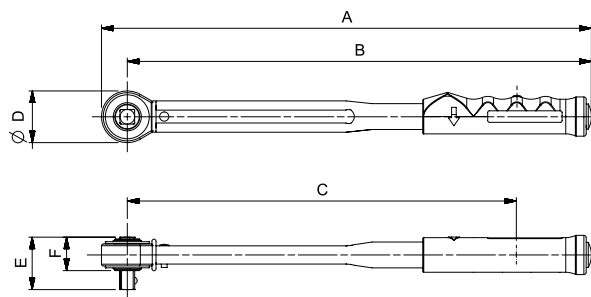

Automotive Ratchet

| Model | Pro 60, 3/8" | Pro 60, 1/2" | Pro 100, 3/8" | Pro 100, 1/2" | Pro 200 |
|-----------------|--------------|--------------|---------------|---------------|---------|
| Part Number | 11164 | 11171 | 11138 | 11139 | 11140 |
| Dimensions (mm) | A | 289 | 289 | 351 | 351 |
| | B | 274 | 274 | 314 | 314 |
| | C | 209 | 209 | 249 | 249 |
| | ∅D | 30 | 30 | 30 | 30 |
| | E | 33 | 38 | 33 | 38 |
| | F | 22 | 22 | 22 | 22 |
| Weight (kg) | 0.6 | 0.6 | 0.7 | 0.7 | 1 |

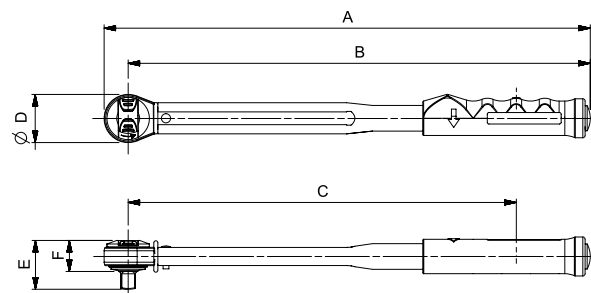

Spigot Torque Handle

| Model | Pro 60 | Pro 100 | Pro 200 | Pro 300 |
|-----------------|--------|---------|---------|---------|
| Part Number | 11167 | 11143 | 11144 | 11117 |
| Dimensions (mm) | A | 283 | 324 | 405 |
| | B | 277 | 317 | 399 |
| | C | 212 | 252 | 334 |
| | ∅D | 16 | 16 | 16 |
| Weight (kg) | 0.6 | 0.6 | 0.8 | 1.1 |

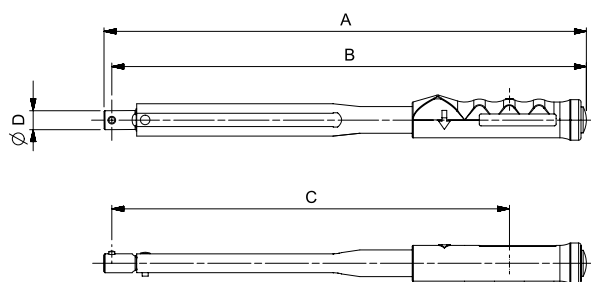

Female Torque Handle

| Model | Pro 60 9 x 12 mm | Pro 100 9 x 12 mm | Pro 200, 9 x 12 mm | Pro 200, 14 x 18 mm | Pro 300 14 x 18 mm | Pro 400 14 x 18 mm |
|-----------------|---------------------|----------------------|-----------------------|------------------------|-----------------------|-----------------------|
| Part Number | 11170 | 11150 | 11151 | 11152 | 11153 | 13068 |
| Dimensions (mm) | A | 286 | 326 | 403 | 414 | 534 |
| | B | 274 | 314 | 392 | 400 | 518 |
| | C | 210 | 250 | 327 | 336 | 453 |
| | D | 22 | 22 | 25 | 34 | 36 |
| | E | 20 | 20 | 20 | 26 | 28 |
| Weight (kg) | 0.6 | 0.6 | 0.8 | 0.8 | 1.1 | 1.8 |

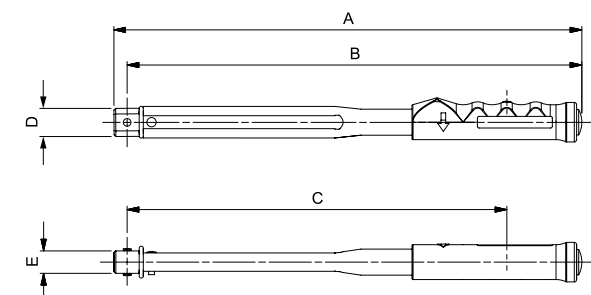



PROFESSIONAL TORQUE WRENCHES



Since its original, award winning launch in 1984, Norbar's Professional torque wrench range has become one of the most popular wrench ranges available worldwide. In this re-engineered version, the core principles of accuracy, durability and comfort are carried over but almost every component part is new and improved.

- Accurate to $\pm 3\%$ of reading which meets the requirements of ISO 6789-2:2017
- Supplied with a traceable 'Calibration Certificate' allowing end users to adhere to more stringent quality control processes
- Large scale for better visibility and more accurate setting
- Fast scale adjustment reducing the effort required to adjust
- If you adjust your wrench regularly, you can do more work



• Imperial scale only models available, contact Norbar



Pro 15 & 25
Automotive Ratchets



Unlocked



Locked



Female Torque Handle



16 mm Spigot End

Compared with other torque wrenches:

Norbar's 'harmonic drive' scale provides a long scale length for good resolution and accurate setting in both scale units. By contrast, micrometer type scales allow accurate setting in the primary scale unit but relatively poor accuracy of setting in the secondary units because of limited resolution. The Professional wrench is amongst the easiest wrenches on the market to accurately set.



PROFESSIONAL TORQUE WRENCHES



There will be a phased change to the 'Industrial Ratchet' on our Professional range of torque wrenches. Norbar will be moving from the 'Mushroom' square drive to a captive 'push-through' square drive

2 INDUSTRIAL RATCHET - DUAL SCALE

| | |
|--------|--|
| 15002* | Pro 50, 3/8", 10 - 50 N·m, 7.5 - 37.5 lbf·ft |
| 15003 | Pro 100, 1/2", 20 - 100 N·m, 15 - 75 lbf·ft |
| 15004 | Pro 200, 1/2", 40 - 200 N·m, 30 - 150 lbf·ft |
| 15005 | Pro 300, 1/2", 60 - 300 N·m, 44 - 222 lbf·ft |
| 15006 | Pro 340, 1/2", 60 - 340 N·m, 44 - 250 lbf·ft |
| 15007* | Pro 400, 3/4", 80 - 400 N·m, 60 - 300 lbf·ft |

2 INDUSTRIAL RATCHET - N·m ONLY

| | |
|--------|-----------------------------|
| 15042* | Pro 50, 3/8", 10 - 50 N·m |
| 15043 | Pro 100, 1/2", 20 - 100 N·m |
| 15044 | Pro 200, 1/2", 40 - 200 N·m |
| 15045 | Pro 300, 1/2", 60 - 300 N·m |
| 15046 | Pro 340, 1/2", 60 - 340 N·m |
| 15047* | Pro 400, 3/4", 80 - 400 N·m |

2 INDUSTRIAL RATCHET - lbf·ft ONLY

| | |
|--------|---------------------------------|
| 15172* | Pro 50, 3/8", 7.5 - 37.5 lbf·ft |
| 15173 | Pro 100, 1/2", 15 - 75 lbf·ft |
| 15174 | Pro 200, 1/2", 30 - 150 lbf·ft |
| 15175 | Pro 300, 1/2", 44 - 220 lbf·ft |
| 15176 | Pro 340, 1/2", 45 - 250 lbf·ft |
| 15177* | Pro 400, 3/4", 60 - 300 lbf·ft |

* Supplied with 1/2" sq. dr. adaptor

· Supplied with 3/8" sq. dr. adaptor

* Model 400 supplied with a Stepped Square

2 AUTOMOTIVE RATCHET (Reversible) - DUAL SCALE

| | |
|-------|--|
| 15220 | Pro 15, 1/4", 3 - 15 N·m, 27 - 132 lbf·in |
| 15221 | Pro 15, 3/8", 3 - 15 N·m, 27 - 132 lbf·in |
| 15222 | Pro 25, 1/4", 5 - 25 N·m, 44 - 220 lbf·in |
| 15223 | Pro 25, 3/8", 5 - 25 N·m, 44 - 220 lbf·in |
| 15012 | Pro 50, 3/8", 10 - 50 N·m, 7.5 - 37.5 lbf·ft |
| 15013 | Pro 50, 1/2", 10 - 50 N·m, 7.5 - 37.5 lbf·ft |
| 15014 | Pro 100, 3/8", 20 - 100 N·m, 15 - 75 lbf·ft |
| 15015 | Pro 100, 1/2", 20 - 100 N·m, 15 - 75 lbf·ft |

2 AUTOMOTIVE RATCHET (Reversible) - N·m ONLY

| | |
|-------|-----------------------------|
| 15224 | Pro 15, 1/4", 3 - 15 N·m |
| 15225 | Pro 15, 3/8", 3 - 15 N·m |
| 15226 | Pro 25, 1/4", 5 - 25 N·m |
| 15227 | Pro 25, 3/8", 5 - 25 N·m |
| 15022 | Pro 50, 3/8", 10 - 50 N·m |
| 15023 | Pro 50, 1/2", 10 - 50 N·m |
| 15024 | Pro 100, 3/8", 20 - 100 N·m |
| 15025 | Pro 100, 1/2", 20 - 100 N·m |





PROFESSIONAL TORQUE WRENCHES



2 TORQUE HANDLE ADJUSTABLE 16 mm SPIGOT - DUAL SCALE

| | |
|-------|--|
| 15060 | Pro 15, 16 mm spigot, 3 - 15 N·m, 27 - 132 lbf·in |
| 15061 | Pro 25, 16 mm spigot, 5 - 25 N·m, 44 - 220 lbf·in |
| 15062 | Pro 50, 16 mm spigot, 10 - 50 N·m, 7.5 - 37.5 lbf·ft |
| 15063 | Pro 100, 16 mm spigot, 20 - 100 N·m, 15 - 75 lbf·ft |
| 15064 | Pro 200, 16 mm spigot, 40 - 200 N·m, 30 - 150 lbf·ft |
| 15065 | Pro 300, 16 mm spigot, 60 - 300 N·m, 44 - 222 lbf·ft |

2 TORQUE HANDLE ADJUSTABLE 16 mm SPIGOT - N·m ONLY

| | |
|-------|-------------------------------------|
| 15070 | Pro 15, 16 mm spigot, 3 - 15 N·m |
| 15071 | Pro 25, 16 mm spigot, 5 - 25 N·m |
| 15072 | Pro 50, 16 mm spigot, 10 - 50 N·m |
| 15073 | Pro 100, 16 mm spigot, 20 - 100 N·m |
| 15074 | Pro 200, 16 mm spigot, 40 - 200 N·m |
| 15075 | Pro 300, 16 mm spigot, 60 - 300 N·m |

2 FEMALE TORQUE HANDLE ADJUSTABLE - DUAL SCALE

| | |
|-------|--|
| 15100 | Pro 15, 9 x 12 mm, 3 - 15 N·m, 27 - 132 lbf·in |
| 15101 | Pro 25, 9 x 12 mm, 5 - 25 N·m, 44 - 220 lbf·in |
| 15102 | Pro 50, 9 x 12 mm, 10 - 50 N·m, 7.5 - 37.5 lbf·ft |
| 15103 | Pro 100, 9 x 12 mm, 20 - 100 N·m, 15 - 75 lbf·ft |
| 15104 | Pro 200, 9 x 12 mm, 40 - 200 N·m, 30 - 150 lbf·ft |
| 15105 | Pro 200, 14 x 18 mm, 40 - 200 N·m, 30 - 150 lbf·ft |
| 15106 | Pro 300, 14 x 18 mm, 60 - 300 N·m, 44 - 222 lbf·ft |
| 15107 | Pro 340, 14 x 18 mm, 60 - 340 N·m, 44 - 250 lbf·ft |
| 15108 | Pro 400, 14 x 18 mm, 80 - 400 N·m, 60 - 300 lbf·ft |

2 FEMALE TORQUE HANDLE ADJUSTABLE - N·m ONLY

| | |
|-------|-----------------------------------|
| 15110 | Pro 15, 9 x 12 mm, 3 - 15 N·m |
| 15111 | Pro 25, 9 x 12 mm, 5 - 25 N·m |
| 15112 | Pro 50, 9 x 12 mm, 10 - 50 N·m |
| 15113 | Pro 100, 9 x 12 mm, 20 - 100 N·m |
| 15114 | Pro 200, 9 x 12 mm, 40 - 200 N·m |
| 15115 | Pro 200, 14 x 18 mm, 40 - 200 N·m |
| 15116 | Pro 300, 14 x 18 mm, 60 - 300 N·m |
| 15117 | Pro 340, 14 x 18 mm, 60 - 340 N·m |
| 15118 | Pro 400, 14 x 18 mm, 80 - 400 N·m |



Pro 25 Torque Handle



Pro 25 Female Torque Handle



PROFESSIONAL TORQUE WRENCHES



Industrial Ratchet

| Model | Pro 50 | Pro 100 | Pro 200 | Pro 300 | Pro 340 | Pro 400 | |
|-----------------|-------------------------|-------------------------|-------------------------|-------------------------|-------------------------|-------------------------|-----|
| Part Number | 15002 15042 15172 | 15003 15043 15173 | 15004 15044 15174 | 15005 15045 15175 | 15006 15046 15176 | 15007 15047 15177 | |
| Dimensions (mm) | A | 335 | 387 | 470 | 593 | 685 | 686 |
| | B | 317 | 364 | 447 | 567 | 659 | 661 |
| | C | 231 | 278 | 361 | 480 | 572 | 574 |
| | ∅D | 35 | 45 | 45 | 52 | 52 | 51 |
| | E | 37 | 48 | 48 | 48 | 48 | 47 |
| | F | 26 | 32 | 32 | 33 | 33 | 24 |
| Weight (kg) | 0.7 | 0.9 | 1.1 | 1.4 | 1.5 | 1.9 | |

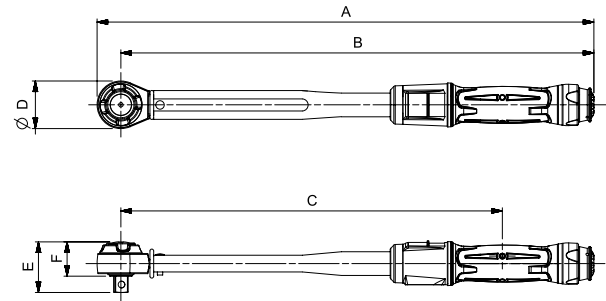

Automotive Ratchet

| Model | Pro 15 Pro 25 | Pro 50 3/8" | Pro 50 1/2" | Pro 100 3/8" | Pro 100 1/2" | |
|-----------------|--|----------------|----------------|-----------------|-----------------|-----|
| Part Number | 15220, 15221, 15222, 15223, 15224, 15225, 15226, 15227 | 15012 15022 | 15013 15023 | 15014 15024 | 15015 15025 | |
| Dimensions (mm) | A | 221 | 327 | 327 | 367 | 367 |
| | B | 209 | 312 | 312 | 352 | 352 |
| | C | 140 | 226 | 226 | 266 | 266 |
| | ∅D | 25 | 30 | 30 | 30 | 30 |
| | E | 25 | 33 | 38 | 33 | 38 |
| | F | 18 | 22 | 22 | 22 | 22 |
| Weight (kg) | 0.3 | 0.7 | 0.7 | 0.8 | 0.8 | |

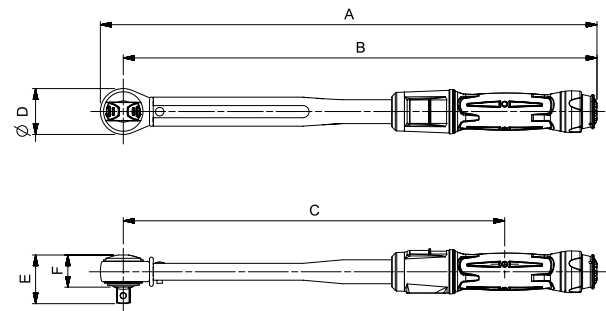

Spigot Torque Handle

| Model | Pro 15 Pro 25 | Pro 50 | Pro 100 | Pro 200 | Pro 300 | |
|-----------------|----------------------------------|----------------|----------------|----------------|----------------|-----|
| Part Number | 15060 15061 15070 15071 | 15062 15072 | 15063 15073 | 15064 15074 | 15065 15075 | |
| Dimensions (mm) | A | 223 | 322 | 363 | 445 | 569 |
| | B | 216 | 316 | 356 | 438 | 563 |
| | C | 148 | 229 | 269 | 351 | 476 |
| | ∅D | 16 | 16 | 16 | 16 | 16 |
| Weight (kg) | 0.3 | 0.6 | 0.7 | 0.9 | 1.2 | |

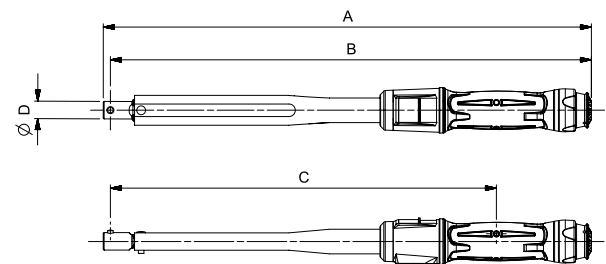

Female Torque Handle

| Model | Pro 15 Pro 25 | Pro 50 | Pro 100 | Pro 200 9 x 12 mm | Pro 200 14 x 18 mm | Pro 300 | Pro 340 | Pro 400 | |
|-----------------|----------------------------------|----------------|----------------|----------------------|-----------------------|----------------|----------------|----------------|-----|
| Part Number | 15100 15101 15110 15111 | 15102 15112 | 15103 15113 | 15104 15114 | 15105 15115 | 15106 15116 | 15107 15117 | 15108 15118 | |
| Dimensions (mm) | A | 218 | 325 | 365 | 442 | 453 | 570 | 662 | 664 |
| | B | 204 | 314 | 354 | 431 | 440 | 557 | 649 | 649 |
| | C | 139 | 227 | 267 | 345 | 353 | 440 | 562 | 563 |
| | D | 22 | 22 | 22 | 25 | 34 | 34 | 34 | 32 |
| | E | 20 | 20 | 20 | 20 | 26 | 28 | 28 | 24 |
| Weight (kg) | 0.3 | 0.6 | 0.7 | 0.9 | 1.0 | 1.2 | 1.3 | 1.7 | |

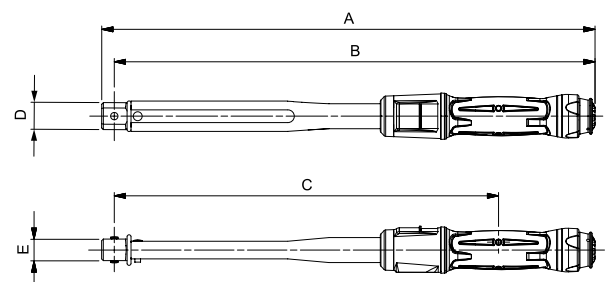



XR PRO TORQUE WRENCHES



New

It splits, it clicks,
its built to last



Introducing the XR Professional, a new large torque wrench that extends our established popular Professional torque wrench range. Designed to meet the demands of high-torque applications, the XR Professional is available in torque ranges up to 1,000 N·m, delivering exceptional strength, accuracy and reliability for today's most challenging industrial applications.

- Accurate to ±4% of reading which exceeds the requirements of ISO 6789-1:2017, our wrenches deliver lasting precision and reliability, maintaining accuracy use after use for consistent, dependable results you can trust
- Large easy-to-read scale with light and fast adjustment saves operator time and effort, keeping you productive, precise, and in full control of every task
- Alignment Pin physically prevents the use of incompatible attachments, thereby reducing the risk of improper setup
- Push/pull lock prevents accidental adjustment of the set torque
- Push through ratchet allows clockwise and counterclockwise operations
- Can be split and packed in two parts for a smaller, easier to transport package

| 2 | ADJUSTABLE RATCHET |
|-------|--|
| 14051 | XR Pro 600, 3/4", 120 - 600 N·m, 90 - 440 lbf-ft |
| 14052 | XR Pro 800, 3/4", 160 - 800 N·m, 120 - 580 lbf-ft |
| 14053 | XR Pro 1000, 3/4", 200 - 1,000 N·m, 150 - 730 lbf-ft |

| 2 | TORQUE HANDLE ADJUSTABLE |
|-------|--|
| 14056 | XR Pro 600, 22 mm spigot, 120 - 600 N·m, 90 - 440 lbf-ft |

| 2 | FEMALE TORQUE HANDLE ADJUSTABLE |
|-------|--|
| 14057 | XR Pro 600, 14 x 18 mm, 120 - 600 N·m, 90 - 440 lbf-ft |

| 2 | RATCHET PRODUCTION 'P' TYPE (Must be set using a Torque Tester, see pages 66 - 73) |
|-------|---|
| 14058 | XR Pro 600, 3/4", 120 - 600 N·m, 90 - 440 lbf-ft |
| 14059 | XR Pro 800, 3/4", 160 - 800 N·m, 120 - 580 lbf-ft |
| 14060 | XR Pro 1000, 3/4", 200 - 1,000 N·m, 150 - 730 lbf-ft |

| 2 | TORQUE HANDLE PRODUCTION 'P' TYPE (Must be set using a Torque Tester, see pages 66 - 73) |
|-------|---|
| 14042 | XR Pro 600, 22 mm spigot, 120 - 600 N·m, 90 - 440 lbf-ft |

| 2 | FEMALE TORQUE HANDLE PRODUCTION 'P' TYPE (Must be set using a Torque Tester, see pages 66 - 73) |
|-------|--|
| 14043 | XR Pro 600, 14 x 18 mm, 120 - 600 N·m, 120 - 440 lbf-ft |

SQ2222 Pre-set, etch and certify
(Allow 3 days delivery for this service)

Included in the case:
Split tool, additional
1" square drive, set of
instructions and Certificate
of Calibration



Supplied in a sturdy carry
case for storage and
protection



XR PRO TORQUE WRENCHES



| Model | XR Pro 600 | | XR Pro 800 | | XR Pro 1000 | | XR Pro 600 'P' Type | | XR Pro 800 'P' Type | | XR Pro 1000 'P' Type | | | |
|-----------------|------------|----|------------|------|-------------|------|---------------------|------|---------------------|------|----------------------|------|------|------|
| Part Number | 14051 | | 14052 | | 14053 | | 14058 | | 14059 | | 14060 | | | |
| Square Drive | 3/4" | 1" | 3/4" | 1" | 3/4" | 1" | 3/4" | 1" | 3/4" | 1" | 3/4" | 1" | | |
| Dimensions (mm) | A | | 984 | | 1179 | | 1429 | | 984 | | 1179 | | 1429 | |
| | B | | 951 | | 1142 | | 1392 | | 951 | | 1142 | | 1392 | |
| | C | | 859 | | 1050 | | 1300 | | 859 | | 1050 | | 1300 | |
| | ØD | | 66 | | 74 | | 74 | | 66 | | 74 | | 74 | |
| | E | | 55 | 62.5 | 58 | 65.5 | 58 | 65.5 | 55 | 62.5 | 58 | 65.5 | 58 | 65.5 |
| | F | | 35 | | 38 | | 38 | | 35 | | 38 | | 38 | |
| Weight (kg) | 3.5 | | 4.65 | | 5.3 | | 3.5 | | 4.65 | | 5.3 | | | |



Female Torque Handle (left)
Spigot Torque Handle (right)

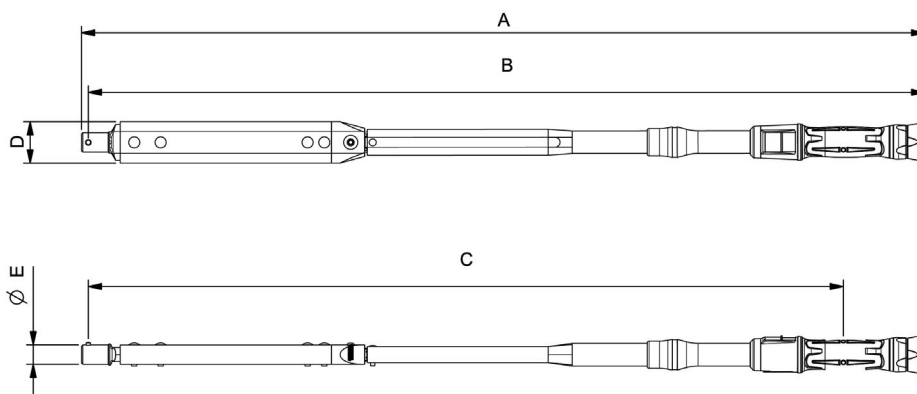
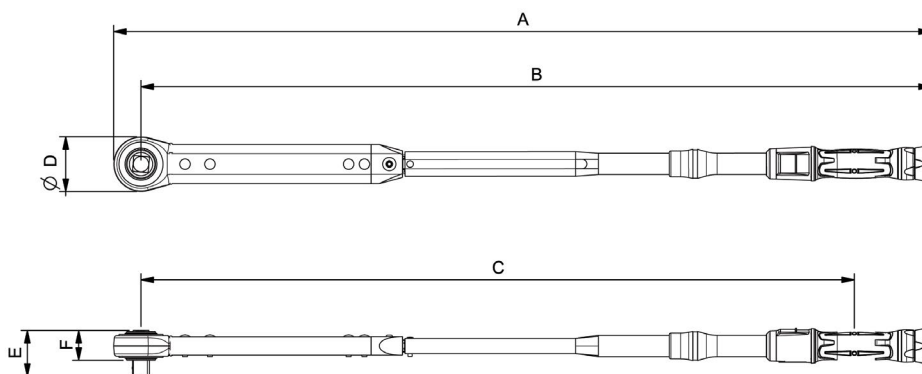

Spigot Torque Handle

| Model | XR Pro 600 | XR Pro 600 'P' Type |
|-----------------|------------|---------------------|
| Part Number | 14056 | 14061 |
| Dimensions (mm) | A | 958 |
| | B | 951 |
| | C | 858 |
| | D | 47 |
| | ØE | 22 |
| Weight (kg) | 3.25 | 3.25 |

Female Torque Handle

| Model | XR Pro 600 | XR Pro 600 'P' Type |
|-----------------|------------|---------------------|
| Part Number | 14057 | 14062 |
| Dimensions (mm) | A | 951 |
| | B | 937 |
| | C | 844 |
| | D | 35 |
| | E | 47 |
| | F | 23 |
| Weight (kg) | 3.25 | 3.25 |

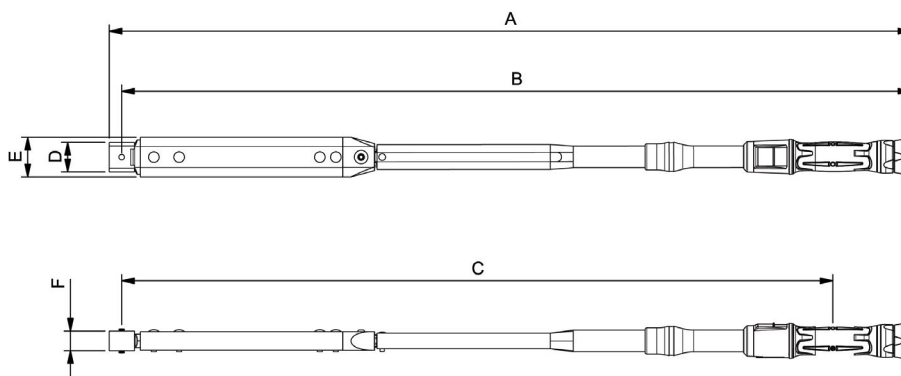



INDUSTRIAL TORQUE WRENCHES ADJUSTABLE & 'P' TYPE - NEW GENERATION



A long-time customer favourite for their unmistakable signal and robustness but now simple to accurately set and split for ease of storage and transportation.

- Unique profiled cam and reaction plate - gives clear torque break point reducing the possibility of over-torquing
- Robust construction gives accurate results to ±4% even in arduous working conditions, meeting the requirements of ISO 6789-1:2017
- Easy to read scale is shielded from dust, dirt and spray
- Easy to set accurately
- Can be split and packed in two parts for a smaller, easier to transport package
- Push-through ratchet allows two direction torquing (Not available for 6R-N models)
- Designed to be cost effectively serviced
- New handle - more comfortable and guides operator's hand to correct position



| 2 RATCHET ADJUSTABLE - DUAL SCALE | |
|-----------------------------------|--|
| 120101 | 3AR-N, ¾", 120 - 600 N·m, 100 - 450 lbf-ft |
| 120101.01 | 3AR-N, 1", 120 - 600 N·m, 100 - 450 lbf-ft |
| 120110 | 4AR-N, ¾", 200 - 800 N·m, 150 - 600 lbf-ft |
| 120110.01 | 4AR-N, 1", 200 - 800 N·m, 150 - 600 lbf-ft |
| 120115 | 5R-N, ¾", 300 - 1,000 N·m, 200 - 750 lbf-ft |
| 120115.01 | 5R-N, 1", 300 - 1,000 N·m, 200 - 750 lbf-ft |
| 120118 | 5AR-N, ¾", 700 - 1,500 N·m, 500 - 1,000 lbf-ft |
| 120118.01 | 5AR-N, 1", 700 - 1,500 N·m, 500 - 1,000 lbf-ft |
| 120120 | 6R-N, 1", 900 - 2,000 N·m, 700 - 1,500 lbf-ft |

| 2 RATCHET ADJUSTABLE - N·m ONLY | |
|---------------------------------|----------------------------|
| 120107 | 3AR-N, ¾", 120 - 600 N·m |
| 120107.01 | 3AR-N, 1", 120 - 600 N·m |
| 120114 | 4AR-N, ¾", 200 - 800 N·m |
| 120114.01 | 4AR-N, 1", 200 - 800 N·m |
| 120117 | 5R-N, ¾", 300 - 1,000 N·m |
| 120117.01 | 5R-N, 1", 300 - 1,000 N·m |
| 120119 | 5AR-N, ¾", 700 - 1,500 N·m |
| 120119.01 | 5AR-N, 1", 700 - 1,500 N·m |
| 120121 | 6R-N, 1", 900 - 2,000 N·m |

| 2 TORQUE HANDLE ADJUSTABLE - DUAL SCALE | |
|---|--|
| 120102 | 3AR-N, 22 mm spigot, 120 - 600 N·m, 100 - 450 lbf-ft |

| 2 TORQUE HANDLE ADJUSTABLE - N·m ONLY | |
|---------------------------------------|------------------------------------|
| 120108 | 3AR-N, 22 mm spigot, 120 - 600 N·m |



| 2 RATCHET PRODUCTION 'P' TYPE (Must be set using a Torque Tester, see pages 81-88) | |
|---|---|
| 120104 | 3AR-N, ¾", 120 - 600 N·m, 100 - 450 lbf-ft |
| 120104.01 | 3AR-N, 1", 120 - 600 N·m, 100 - 450 lbf-ft |
| 120111 | 4AR-N, ¾", 200 - 800 N·m, 150 - 600 lbf-ft |
| 120111.01 | 4AR-N, 1", 200 - 800 N·m, 150 - 600 lbf-ft |
| 120116 | 5R-N, ¾", 300 - 1,000 N·m, 200 - 750 lbf-ft |
| 120116.01 | 5R-N, 1", 300 - 1,000 N·m, 200 - 750 lbf-ft |
| 120130 | 5AR-N, ¾", 700 - 1,500 N·m, 500 - 1,000 lbf-ft |
| 120130.01 | 5AR-N, 1", 700 - 1,500 N·m, 500 - 1,000 lbf-ft |
| SQ2222 | Pre-set, etch and certify (Allow 3 days delivery for this service) |

| 2 TORQUE HANDLE PRODUCTION 'P' TYPE (Must be set using a Torque Tester, see pages 81-88) | |
|---|---|
| 120105 | 3AR-N, 22 mm spigot, 120 - 600 N·m, 100 - 450 lbf-ft |
| SQ2222 | Pre-set, etch and certify (Allow 3 days delivery for this service) |



INDUSTRIAL TORQUE WRENCHES ADJUSTABLE AND 'P' TYPE - NEW GENERATION



Industrial Push-Through Ratchets

| Model | 3AR-N | 3AR-N 'P' Type | 4AR-N | 4AR-N 'P' Type | 5R-N | 5R-N 'P' Type | 5AR-N | 5AR-N 'P' Type | 6R-N |
|-----------------|--|---------------------|--|---------------------|--|---------------------|--|---------------------|------------------|
| Part Number | 120101 120101.01 120107 120107.01 | 120104 120104.01 | 120110 120110.01 120114 120114.01 | 120111 120111.01 | 120115 120115.01 120117 120117.01 | 120116 120116.01 | 120118 120118.01 120119 120119.01 | 120130 120130.01 | 120120 120121 |
| Dimensions (mm) | A | 954 | 1,214 | 1,214 | 1,449 | 1,449 | 1,764 | 1,764 | 1,855 |
| | B | 920 | 1,180 | 1,180 | 1,415 | 1,224 | 1,730 | 1,730 | 1,820 |
| | C | 829 | 1,089 | 1,089 | 1,324 | 1,324 | 1,608 | 1,608 | 1,773 |
| | ØD | 69 | 69 | 69 | 69 | 69 | 69 | 69 | 69 |
| | E | 75 | 75 | 75 | 75 | 75 | 75 | 75 | 75 |
| | F | 479 | 738 | 738 | 974 | 974 | 1,379 | 1,379 | 1,379 |
| | G | ¾" = 55 1" = 63 | ¾" = 55 1" = 63 | ¾" = 55 1" = 63 | ¾" = 55 1" = 63 | ¾" = 55 1" = 63 | ¾" = 55 1" = 63 | ¾" = 55 1" = 63 | 63 |
| | H | 35 | 35 | 35 | 35 | 35 | 35 | 35 | 35 |
| | J max. | 105 | 18 | 105 | 18 | 105 | 18 | 105 | 18 |
| | ØK | 38 | 38 | 38 | 38 | 38 | 38 | 38 | 38 |
| Weight (kg) | 6.0 | 6.0 | 6.7 | 6.7 | 7.4 | 7.4 | 9.6 | 9.6 | 12.75 |



5AR-N adjusting nut (left) alongside the double-barrelled 6R-N adjusting nuts

Packed dimensions: (L x W x H)
 3AR-N to 5R-N: 970 x 260 x 95 mm
 5AR-N & 6R-N: 1,172 x 243 x 91 mm
 4AR-N shown split in case

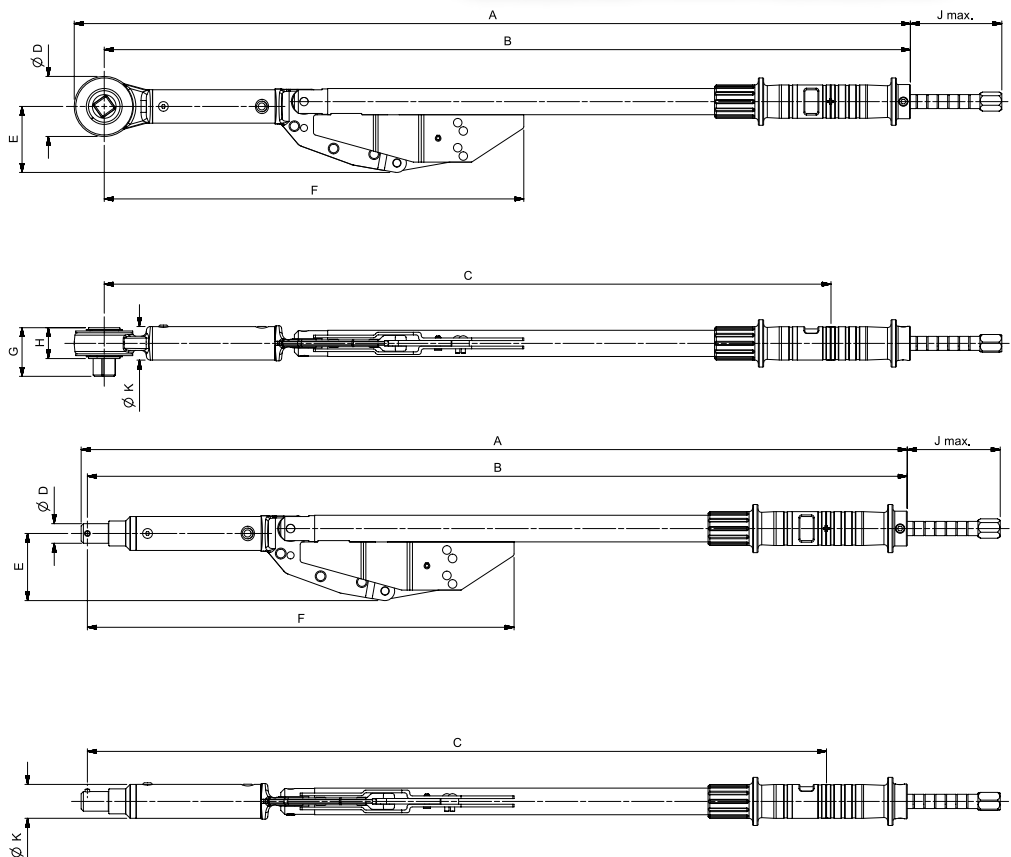

Spigot Torque Handle

| Model | 3AR-N | 3AR-N 'P' Type |
|-----------------|------------------|----------------|
| Part Number | 120102 120108 | 120105 |
| Dimensions (mm) | A | 927 |
| | B | 920 |
| | C | 829 |
| | ØD | 22 |
| | E | 75 |
| | F | 479 |
| | J max. | 105 |
| | ØK | 38 |
| Weight (kg) | 6.0 | 5.3 |

Design Nos. 182086 and 182087 (Canada); Design Nos. 004671063-0001 and 004671063-0002 (EU); Design Nos. D863904 and D871870 (USA)



INDUSTRIAL TORQUE WRENCH - BI-SQUARE

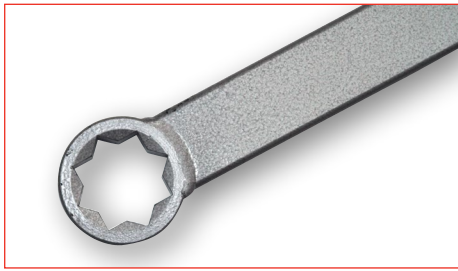

The 1¹/₁₆" Bi-Square Industrial Torque Wrench variant has been engineered specifically for rail track maintenance applications. By fitting directly onto rail fishplate bolts, it eliminates the need for sockets or square drives. This design supports the rail industry's stringent safety objective of preventing foreign objects from being left on the track.

Other versions of this tool are available on request.

| | |
|-------|---|
| 2 | BI-SQUARE - DUAL SCALE |
| 12026 | 1 ¹ / ₁₆ " Bi-Square, 300 - 1,000 N·m, 200 - 750 lbf·ft |

ELECTRODE WRENCHES



For torque tightening of Electrode Wrenches

The correct torque tightening of electrodes is known to increase the energy efficiency of electric arc furnaces and helps prevent electrode sections being lost in the furnace.

Standard torque settings are shown. These are pre-set wrenches and the torque setting is not adjustable by the customer. The torque setting will be supplied at the value shown on this page unless a different torque setting is advised at the time of ordering by the customer (in which case add part number SQ2222 and the required torque value).

The 8" diameter electrode wrench uses the Professional torque handle as the control mechanism. Above 8" the Industrial wrench is used as the control mechanism.

| | |
|--------|--|
| 9 | LOW RANGE |
| 12506 | 8" (200 mm) 312 N·m |
| 12530 | 10" (250 mm) 542 N·m |
| 12531 | 12" (300 mm) 780 N·m |
| SQ2222 | Pre-set, etch and certify (Allow 3 days delivery for this service) |

Other models available on request.

| | |
|--------|--|
| 9 | HIGH RANGE |
| 12532 | 14" (350 mm) 1,140 N·m |
| 12533 | 16" (400 mm) 1,300 N·m |
| 12535 | 18" (450 mm) 1,500 N·m |
| 12536 | 20" (500 mm) 2,000 N·m |
| 12537 | 22" (550 mm) 2,370 N·m |
| 12538 | 24" (600 mm) 2,370 N·m |
| SQ2222 | Pre-set, etch and certify (Allow 3 days delivery for this service) |

| Model | 8" (200 mm) | 10" (250 mm) | 12" (300 mm) | 14" (350 mm) | 16" (400 mm) | 18" (450 mm) | 20" (500 mm) | 22" (550 mm) | 24" (600 mm) | |
|-----------------|-------------|--------------|--------------|--------------|--------------|--------------|--------------|--------------|--------------|-------|
| Part Number | 12506 | 12530 | 12531 | 12532 | 12533 | 12535 | 12536 | 12537 | 12538 | |
| Dimensions (mm) | A | 897 | 1,150 | 1,286 | 1,764 | 1,825 | 1,727 | 2,211 | 2,571 | 2,069 |
| | B | 159 | 194 | 239 | 288 | 299 | 336 | 386 | 398 | 424 |
| | C | 658 | 883 | 994 | 1,443 | 1,472 | 1,643 | 1,811 | 2,141 | 2,140 |
| Weight (kg) | 3.2 | 6.8 | 8.4 | 13.8 | 14.3 | 16.5 | 20.0 | 25.4 | 26.1 | |

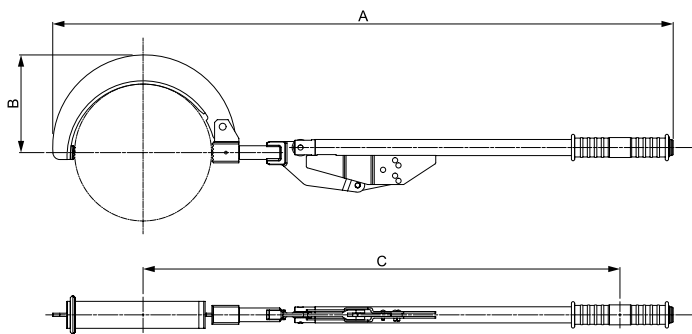

UKAS ACCREDITED CALIBRATION

The part numbers shown below are for a comprehensive calibration, for all new torque screwdrivers and torque wrenches up to the maximum capacity shown. Please see page 131 for Norbar's After Sales Service.

| | |
|----------|--------------------------------|
| 12 | ONE DIRECTION |
| TWCC4.CW | Up to 400 N·m / 300 lbf·ft |
| TWCC5.CW | Up to 1,000 N·m / 750 lbf·ft |
| TWCC6.CW | Up to 3,000 N·m / 2,200 lbf·ft |

| | |
|--------------|--------------------------------|
| 12 | TWO DIRECTIONS |
| TWCC4.CW+CCW | Up to 400 N·m / 300 lbf·ft |
| TWCC5.CW+CCW | Up to 1,000 N·m / 750 lbf·ft |
| TWCC6.CW+CCW | Up to 3,000 N·m / 2,200 lbf·ft |



ELECTRONIC SCREWDRIVER AND TORQUE WRENCHES

ProTronic® Electronic Torque Wrenches 32
 ProTronic® Plus Electronic Torque Wrenches 33
 ProTronic® Plus Electronic Torque Screwdriver 34
 ProTronic® Plus Model 10 and Model 30 34
 ProTronic® Plus TorqApp™ 35
 Spanner End Fittings for 16 mm Torque Handles 36
 Spanner End Fittings for 22 mm Torque Handles 37
 Spigot Accessories 37
 Large Spanner End Fittings for 16 mm Spigot Torque Handles up to 300 N·m 38
 Large Spanner End Fittings for 22 mm Spigot Torque Handles up to 650 N·m 39

Norbar Torque Tools offers a range of high-precision electronic torque tools including a screwdriver and an extensive selection of torque wrenches to cover torque values from 0.45 to 800 N·m.

Many of the options in this section have the capability to connect to software that more easily manages data and configures settings. These highly accurate electronic torque and angle tools are the perfect solution for applications that require precision and control.





PROTRONIC® ELECTRONIC TORQUE WRENCHES



The ProTronic® is a high precision electronic torque wrench with a large backlit LCD display, that measures accurate and consistent torque readings. It also features an audible buzzer when pre-set torque/angle value is reached.

- Dual progressive LEDs positioned both sides of the wrench provide an easy visual representation of torque progress allowing the user to more easily anticipate torque target
- Large LCD screen with bright backlight; numbers become larger and bolder during active torque for optimal viewing
- Four alert modes (LCD, progressive LED, audible, vibration) provide excellent feedback in all working conditions
- 5 easily selectable torque units: N·m, lbf·ft, lbf·in, dN·m, kg·cm and kg·m (200 N·m and above)
- The ability to programme up to 10 pre-sets in the tool saves time in setting up frequently occurring applications
- A wide range of advanced features (cycle counter, customisable sleep timer, language selection, auto torque calculation for torque adaptors, calibration alerts, battery level indication, and numerous alert mode customisations) allow the user to tailor the tool to their work preferences
- Torque THEN Angle mode gives the user the ability to conveniently apply an angle to a fastener directly after achieving a torque target without the need to remove the torque wrench from the application
- Settings allow for operation in either English, Spanish, French, German, Italian, Dutch or Portuguese
- Power interruption technology helps to prevent loss of work and continuity if the wrench is impacted
- Patent pending built-in calibration factor feature allows different head lengths to be easily accommodated
- Supplied with a traceable 'Calibration Certificate' conforming with ISO 6789-2:2017, allowing end users to adhere to more stringent quality control processes

| 4 | PROTRONIC |
|--------|-----------------------------------|
| 130517 | ProTronic 100, 3/8", 5 - 100 N·m |
| 130518 | ProTronic 100, 1/2", 5 - 100 N·m |
| 130519 | ProTronic 200, 1/2", 10 - 200 N·m |
| 130520 | ProTronic 340, 1/2", 17 - 340 N·m |

| Model | ProTronic 100 3/8" | ProTronic 100 1/2" | ProTronic 200 1/2" | ProTronic 340 1/2" |
|-----------------|--------------------|--------------------|--------------------|--------------------|
| Part Number | 130517 | 130518 | 130519 | 130520 |
| Dimensions (mm) | A | 458 | 462 | 650 |
| | B | 439 | 439 | 627 |
| | C | 344 | 344 | 533 |
| | ØD | 38 | 46 | 46 |
| | E | 34 | 45 | 45 |
| | F | 21 | 29 | 29 |
| Weight (kg) | 1.15 | 1.30 | 1.65 | 1.85 |

ProTronic Standard Range



- Accuracy of ±2% when operating between 20% to 100% of tool capacity
- Angle accuracy of ±1% of reading, ±1° @ Angular Velocity >10°/Sec < 180°/Sec, ±1° for test fixture

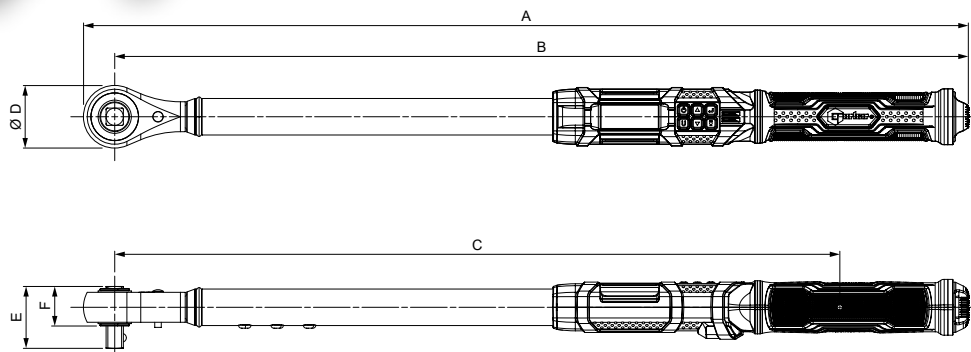



PROTRONIC® PLUS ELECTRONIC TORQUE WRENCHES



The ProTronic® Plus retains all the features available in the ProTronic® standard versions and then adds more. Equipped with Bluetooth®, the ProTronic® Plus works alongside a specially created app that allows uploading of wrench configurations and logging of streamed torque and angle readings.

- Patent pending Torque AND Angle combo modes allow the user to monitor torque and angle simultaneously
- Works alongside newly developed TorqApp™ designed for live streaming of readings as they are taken
- Dual progressive LEDs have additional settings allowing customisation to user preference
- Up to 50 pre-sets can be programmed into the tool. Preset lock feature allows the tool to be set-up with only these pre-sets available to the operator
- Sequence programming and job modes allows the user to chain together pre-sets in a particular sequence
- UKAS accredited torque calibration in both clockwise and counter-clockwise direction

| 4 | PROTRONIC PLUS |
|--------|--|
| 130512 | ProTronic Plus 100, 3/8", 5 - 100 N-m |
| 130513 | ProTronic Plus 100, 1/2", 5 - 100 N-m |
| 130514 | ProTronic Plus 200, 1/2", 10 - 200 N-m |
| 130515 | ProTronic Plus 340, 1/2", 17 - 340 N-m |
| 130516 | ProTronic Plus 800, 3/4", 40 - 800 N-m |

- Accuracy of ±2% when operating between 20% to 100% of tool capacity.
- Accuracy of ±4% when operating between 5% to 19% of tool capacity, except for ProTronic® Plus 9, 10 and 30 where the counter clockwise accuracy between 5% to 19% will be 6%.
- Angle accuracy of ±1% of reading, ±1° @ Angular Velocity >10°/Sec < 180°/Sec, ±1° for test fixture

| Model | ProTronic Plus 100 3/8" | ProTronic Plus 100 1/2" | ProTronic Plus 200 1/2" | ProTronic Plus 340 1/2" | ProTronic Plus 800 3/4" |
|-----------------|-------------------------|-------------------------|-------------------------|-------------------------|-------------------------|
| Part Number | 130512 | 130513 | 130514 | 130515 | 130516 |
| Dimensions (mm) | A | 458 | 462 | 650 | 749 |
| | B | 439 | 439 | 627 | 723 |
| | C | 344 | 344 | 533 | 629 |
| | ØD | 38 | 46 | 46 | 52 |
| | E | 34 | 45 | 45 | 45 |
| | F | 21 | 29 | 29 | 29 |
| Weight (kg) | 1.15 | 1.30 | 1.65 | 1.85 | 4.95 |

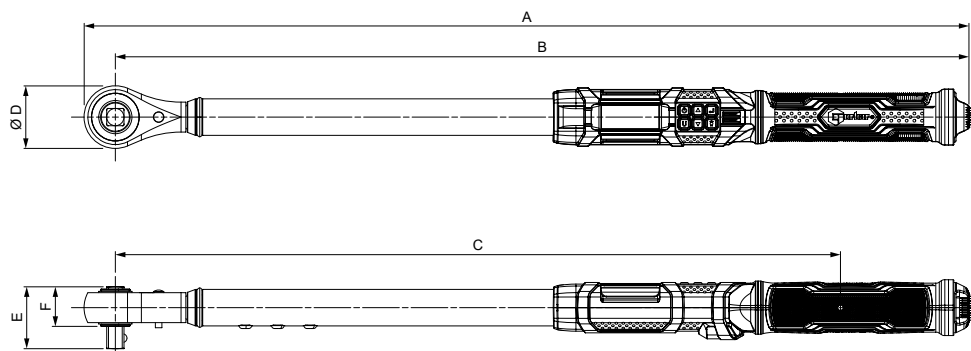

ProTronic Plus Torque Wrench Range





PROTRONIC® PLUS ELECTRONIC TORQUE SCREWDRIVER



4 PROTRONIC PLUS
130524 ProTronic Plus 9, ¼" Female Hex, 0.45 - 9 N-m

The ProTronic® Plus Screwdriver retains all the features of the ProTronic® standard and Plus Wrench in a smaller tool with flush fitted buttons to avoid accidental activation during use.

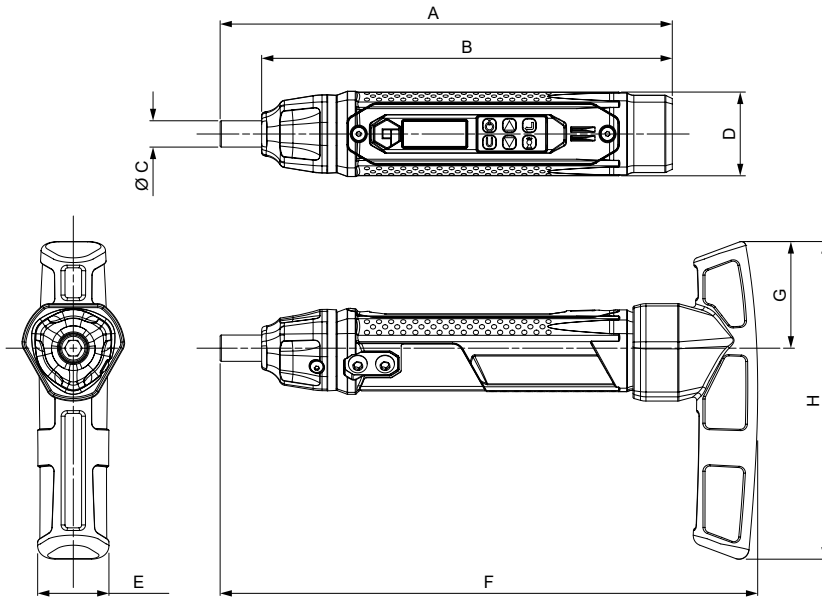

| Model | ProTronic Plus 9 ¼" | |
|----------------------------|---------------------|-----|
| Part Number | 130524 | |
| Dimensions (mm) | A | 190 |
| | B | 173 |
| | Ø C | 11 |
| | D | 35 |
| | E | 30 |
| | F | 226 |
| | G | 44 |
| | H | 131 |
| Weight (kg) without Handle | 0.21 | |
| Weight (kg) with handle | 0.33 | |



PROTRONIC® PLUS MODEL 10 AND MODEL 30



The ProTronic® Plus Model 10 and Model 30 retain all the features of the ProTronic® standard and Plus Wrench in a more compact design allowing for lower torque and access to more space limited applications.

4 PROTRONIC PLUS
130522 ProTronic Plus 10, ¼", 0.5 - 10 N-m
130523 ProTronic Plus 30, ¼", 1.5 - 30 N-m

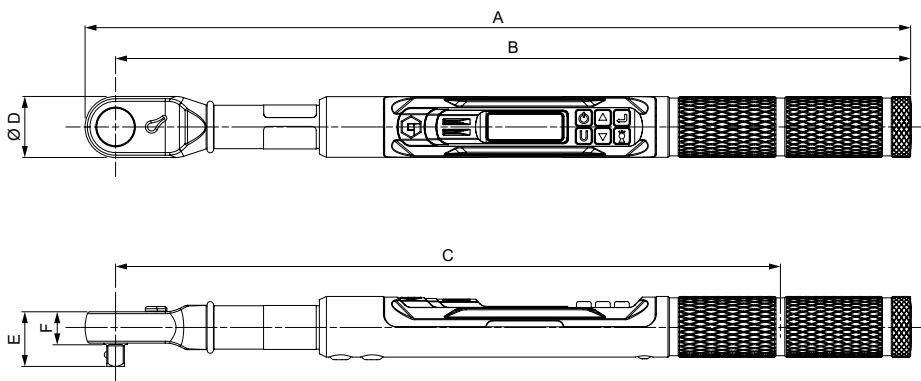

| Model | ProTronic Plus 10 ¼" | ProTronic Plus 30 ¼" |
|-----------------|----------------------|----------------------|
| Part Number | 130522 | 130523 |
| Dimensions (mm) | A | 282 |
| | B | 271 |
| | C | 234 |
| | ØD | 22 |
| | E | 20 |
| | F | 12 |
| Weight (kg) | 0.39 | 0.42 |



PROTRONIC® PLUS TORQAPP™



TorqApp™ is a free, mobile application that connects to ProTronic® Plus, allowing the user to intuitively change tool settings and download results.

- Intuitively change tool settings with ease directly from your device
- Instantly receive individually-completed results, with the ability to email these in .csv format quickly
- Monitor application data and progress in real time aiding the operator in keeping a track of bolting progress, particularly useful for sequenced/linked jobs
- Revisiting failed results when in sequence is easy
- Easily view, download or upload application and tool information for past results helping to keep a comprehensive record for traceability purposes



TorqApp™ can connect to any of these products 1 at a time





SPANNER END FITTINGS FOR 16 mm TORQUE HANDLES

See below for explanation of part numbers. Other sizes available on request – including bespoke ETO solutions.



| 2 | OPEN ENDS METRIC |
|------------|------------------|
| 297102.M07 | 7 mm, 9 N·m* |
| 297102.M08 | 8 mm, 13 N·m* |
| 297102.M09 | 9 mm, 18 N·m* |
| 297102.M10 | 10 mm, 24 N·m* |
| 297102.M11 | 11 mm, 32 N·m* |
| 297102.M12 | 12 mm, 41 N·m* |
| 297102.M13 | 13 mm, 51 N·m* |
| 297102.M14 | 14 mm, 63 N·m* |
| 297102.M15 | 15 mm, 77 N·m* |
| 297102.M16 | 16 mm, 92 N·m* |
| 297102.M17 | 17 mm, 109 N·m* |
| 297102.M18 | 18 mm, 125 N·m* |
| 297102.M19 | 19 mm, 145 N·m* |
| 297102.M20 | 20 mm, 160 N·m* |
| 297102.M21 | 21 mm, 190 N·m* |
| 297102.M22 | 22 mm, 220 N·m* |
| 297102.M23 | 23 mm, 250 N·m* |
| 297102.M24 | 24 mm, 280 N·m* |
| 297102.M25 | 25 mm, 320 N·m* |
| 297102.M26 | 26 mm, 360 N·m* |
| 297102.M27 | 27 mm, 360 N·m* |
| 297102.M28 | 28 mm, 360 N·m* |
| 297102.M30 | 30 mm, 360 N·m* |
| 297102.M32 | 32 mm, 360 N·m* |
| 297102.M36 | 36 mm, 360 N·m* |

| 2 | OPEN ENDS IMPERIAL |
|------------|--------------------|
| 297102.I05 | 5/16", 34 N·m* |
| 297102.I06 | 3/8", 45 N·m* |
| 297102.I07 | 7/16", 72 N·m* |
| 297102.I08 | 1/2", 51 N·m* |
| 297102.I09 | 9/16", 77 N·m* |
| 297102.I10 | 5/8", 92 N·m* |
| 297102.I11 | 11/16", 109 N·m* |
| 297102.I12 | 3/4", 145 N·m* |
| 297102.I13 | 13/16", 190 N·m* |
| 297102.I14 | 7/8", 220 N·m* |
| 297102.I15 | 15/16", 280 N·m* |
| 297102.I16 | 1", 360 N·m* |
| 297102.I17 | 1 1/16", 360 N·m* |
| 297102.I18 | 1 1/8", 360 N·m* |
| 297102.I19 | 1 3/16", 360 N·m* |
| 297102.I20 | 1 1/4", 360 N·m* |

| 2 | RING ENDS METRIC |
|------------|------------------|
| 297103.M07 | 7 mm, 25 N·m* |
| 297103.M08 | 8 mm, 34 N·m* |
| 297103.M09 | 9 mm, 45 N·m* |
| 297103.M10 | 10 mm, 58 N·m* |
| 297103.M11 | 11 mm, 72 N·m* |
| 297103.M12 | 12 mm, 89 N·m* |
| 297103.M13 | 13 mm, 105 N·m* |
| 297103.M14 | 14 mm, 125 N·m* |
| 297103.M15 | 15 mm, 150 N·m* |
| 297103.M16 | 16 mm, 175 N·m* |
| 297103.M17 | 17 mm, 200 N·m* |
| 297103.M18 | 18 mm, 230 N·m* |
| 297103.M19 | 19 mm, 260 N·m* |
| 297103.M20 | 20 mm, 290 N·m* |
| 297103.M21 | 21 mm, 330 N·m* |
| 297103.M22 | 22 mm, 360 N·m* |
| 297103.M23 | 23 mm, 360 N·m* |
| 297103.M24 | 24 mm, 360 N·m* |
| 297103.M26 | 26 mm, 360 N·m* |
| 297103.M27 | 27 mm, 360 N·m* |

| 2 | RING ENDS IMPERIAL |
|------------|--------------------|
| 297103.I05 | 5/16", 34 N·m* |
| 297103.I06 | 3/8", 58 N·m* |
| 297103.I07 | 7/16", 89 N·m* |
| 297103.I08 | 1/2", 105 N·m* |
| 297103.I09 | 9/16", 125 N·m* |
| 297103.I10 | 5/8", 125 N·m* |
| 297103.I11 | 11/16", 125 N·m* |
| 297103.I12 | 3/4", 260 N·m* |
| 297103.I13 | 13/16", 290 N·m* |
| 297103.I14 | 7/8", 360 N·m* |
| 297103.I15 | 15/16", 360 N·m* |
| 297103.I16 | 1", 360 N·m* |
| 297103.I17 | 1 1/16", 360 N·m* |
| 297103.I19 | 1 3/16", 360 N·m* |

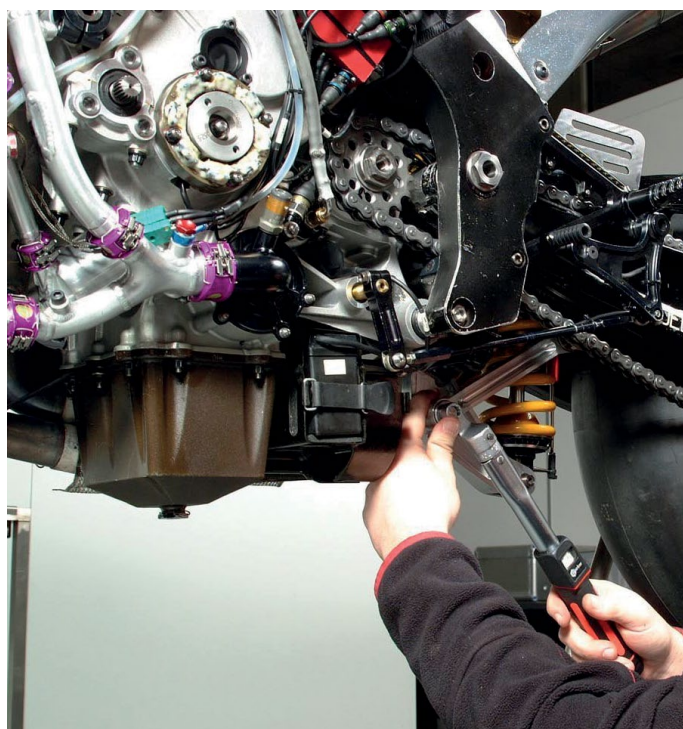

| 2 | FLARE ENDS METRIC |
|------------|-------------------|
| 297104.M07 | 7 mm, 6 N·m* |
| 297104.M08 | 8 mm, 8 N·m* |
| 297104.M09 | 9 mm, 10 N·m* |
| 297104.M10 | 10 mm, 12 N·m* |
| 297104.M11 | 11 mm, 16 N·m* |
| 297104.M12 | 12 mm, 16 N·m* |
| 297104.M13 | 13 mm, 28 N·m* |
| 297104.M14 | 14 mm, 31 N·m* |
| 297104.M15 | 15 mm, 38 N·m* |
| 297104.M16 | 16 mm, 46 N·m* |
| 297104.M17 | 17 mm, 53 N·m* |
| 297104.M18 | 18 mm, 65 N·m* |
| 297104.M19 | 19 mm, 74 N·m* |
| 297104.M20 | 20 mm, 86 N·m* |
| 297104.M21 | 21 mm, 100 N·m* |
| 297104.M22 | 22 mm, 115 N·m* |
| 297104.M23 | 23 mm, 125 N·m* |
| 297104.M24 | 24 mm, 145 N·m* |
| 297104.M27 | 27 mm, 160 N·m* |

* Max torque values listed are proof torques quoted in BS 192:1982 & BS 3555:1988 (tested on hardened hexagon stud).



SPANNER END FITTINGS FOR 22 mm TORQUE HANDLES

See below for explanation of part numbers. Other sizes available on request – including bespoke ETO solutions.



| 2 | OPEN ENDS METRIC |
|------------|-------------------------------|
| 299600.M22 | 22 mm Open End, Max 1,200 N·m |
| 299600.M24 | 24 mm Open End, Max 1,200 N·m |
| 299600.M27 | 27 mm Open End, Max 1,200 N·m |
| 299600.M30 | 30 mm Open End, Max 1,200 N·m |
| 299600.M32 | 32 mm Open End, Max 1,200 N·m |
| 299600.M34 | 34 mm Open End, Max 1,200 N·m |
| 299600.M36 | 36 mm Open End, Max 1,200 N·m |
| 299600.M41 | 41 mm Open End, Max 1,200 N·m |
| 299600.M46 | 46 mm Open End, Max 1,200 N·m |



| 2 | RING ENDS METRIC |
|------------|-------------------------------|
| 299601.M22 | 22 mm Ring End, Max 1,200 N·m |
| 299601.M24 | 24 mm Ring End, Max 1,200 N·m |
| 299601.M27 | 27 mm Ring End, Max 1,200 N·m |
| 299601.M30 | 30 mm Ring End, Max 1,200 N·m |
| 299601.M32 | 32 mm Ring End, Max 1,200 N·m |
| 299601.M34 | 34 mm Ring End, Max 1,200 N·m |
| 299601.M36 | 36 mm Ring End, Max 1,200 N·m |
| 299601.M41 | 41 mm Ring End, Max 1,200 N·m |
| 299601.M46 | 46 mm Ring End, Max 1,200 N·m |

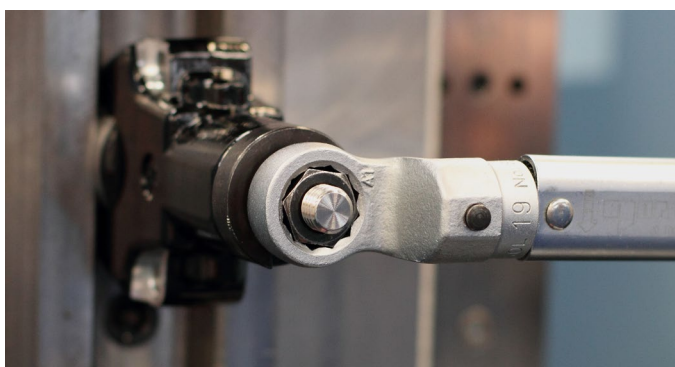
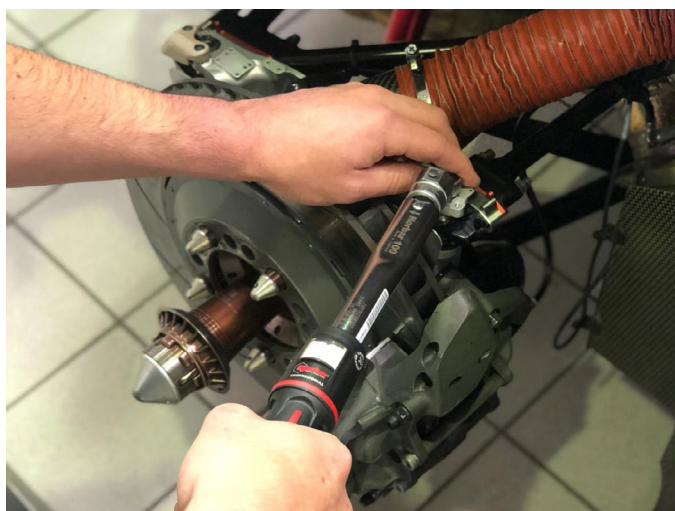

SPIGOT ACCESSORIES



| 2 | 16 mm SPIGOT ACCESSORIES |
|------------|---|
| 44509 | 3/8" Ratchet with Push-through square |
| 29825 | 1/2" Ratchet with Push-through square |
| 44510 | 1/2" Ratchet with Push-through square for NorTronic |
| 29828 | 3/8" Fixed Square Drive |
| 29827 | 1/2" Fixed Square Drive |
| 29829 | 3/8" Reversible Ratchet Head |
| 29830 | 1/2" Reversible Ratchet Head |
| 29832 | Blank End Fitting |
| 85242 | Blank End Fitting for Open End |
| 11343 | Blank End Fitting for Ring End |
| 72000 | Spigot Adaptor 16 mm female to 22 mm male |
| 297105.I04 | 1/4" Square Drive Fixed Head |



| 2 | 22 mm SPIGOT ACCESSORIES |
|------------|---------------------------------------|
| 299602.I12 | 3/4" Square Drive Fixed Head |
| 29972 | 3/4" Ratchet with Push-through square |
| 85719 | Blank End Fitting for Open End |
| 85720 | Blank End Fitting for Ring End |





TORQUE WRENCH END FITTINGS

LARGE SPANNER END FITTINGS FOR 16 mm SPIGOT TORQUE HANDLES UP TO 300 N·m

See below for explanation of part numbers. Other sizes available on request – including bespoke ETO solutions.

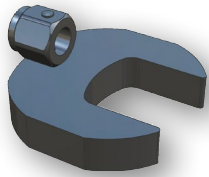

8 OPEN OFFSET
METRIC 16 mm

29218.OO.Mxx | 30 - 80 mm

8 OPEN OFFSET
IMPERIAL 16 mm

29218.OO.lxx | 1 3/16" - 3 1/4"

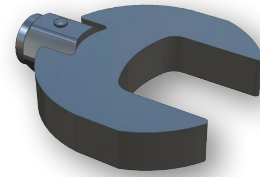

8 OPEN INLINE
METRIC 16 mm

29218.OI.Mxx | 30 - 80 mm

8 OPEN INLINE
IMPERIAL 16 mm

29218.OI.lxx | 1 3/16" - 3 1/4"

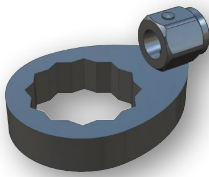

8 RING OFFSET
METRIC 16 mm

29218.RO.Mxx | 30 - 80 mm

8 RING OFFSET
IMPERIAL 16 mm

29218.RO.lxx | 1 3/16" - 3 1/4"

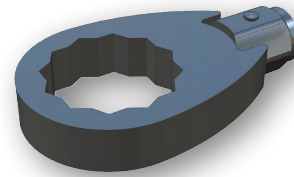

8 RING INLINE
METRIC 16 mm

29218.RI.Mxx | 30 - 80 mm

8 RING INLINE
IMPERIAL 16 mm

29218.RI.lxx | 1 3/16" - 3 1/4"

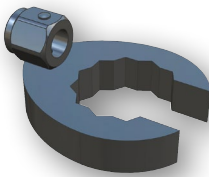

8 FLARE OFFSET
METRIC 16 mm

29218.FO.Mxx | 11 - 80 mm

8 FLARE OFFSET
IMPERIAL 16 mm

29218.FO.lxx | 1 3/16" - 3 1/4"

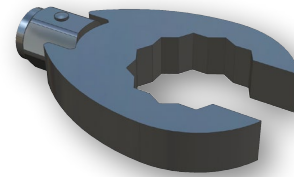

8 FLARE INLINE
METRIC 16 mm

29218.FI.Mxx | 30 - 80 mm

8 FLARE INLINE
IMPERIAL 16 mm

29218.FI.lxx | 1 3/16" - 3 1/4"

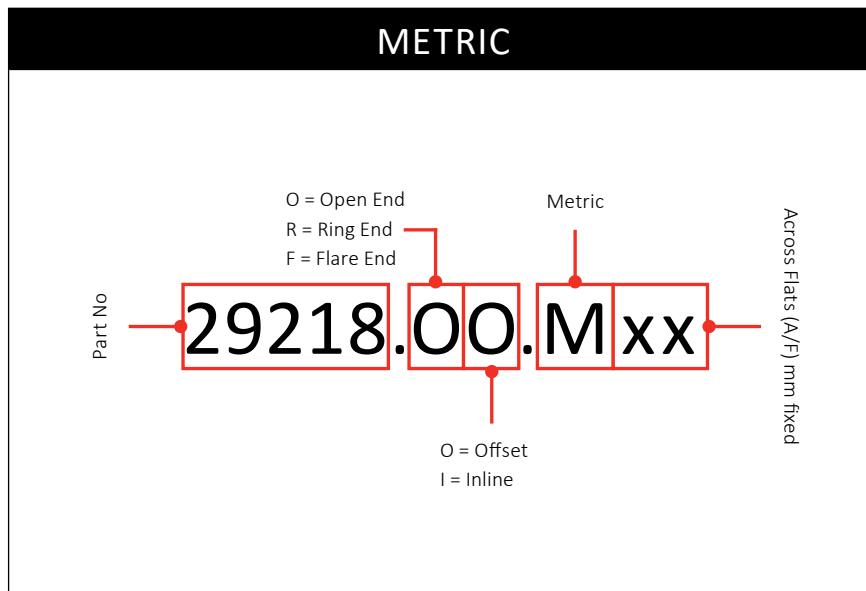



LARGE SPANNER END FITTINGS FOR 22 mm SPIGOT TORQUE HANDLES UP TO 650 N·m

See below for explanation of part numbers. Other sizes available on request – including bespoke ETO solutions.

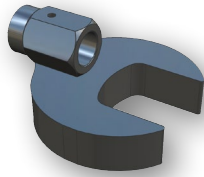

| | | | |
|--------------|-----------------------------|--------------|-------------------------------|
| 8 | OPEN OFFSET METRIC 22 mm | 8 | OPEN OFFSET IMPERIAL 22 mm |
| 29219.OO.Mxx | 30 - 80 mm | 29219.OO.lxx | 1 3/16" - 3 1/4" |

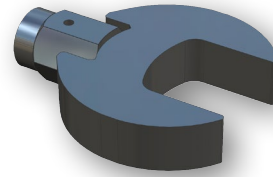

| | | | |
|--------------|-----------------------------|--------------|-------------------------------|
| 8 | OPEN INLINE METRIC 22 mm | 8 | OPEN INLINE IMPERIAL 22 mm |
| 29219.OI.Mxx | 30 - 80 mm | 29219.OI.lxx | 1 3/16" - 3 1/4" |

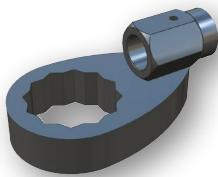

| | | | |
|--------------|-----------------------------|--------------|-------------------------------|
| 8 | RING OFFSET METRIC 22 mm | 8 | RING OFFSET IMPERIAL 22 mm |
| 29219.RO.Mxx | 30 - 80 mm | 29219.RO.lxx | 1 3/16" - 3 1/4" |

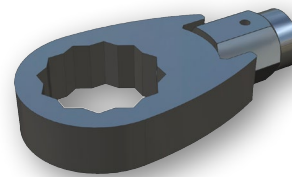

| | | | |
|--------------|-----------------------------|--------------|-------------------------------|
| 8 | RING INLINE METRIC 22 mm | 8 | RING INLINE IMPERIAL 22 mm |
| 29219.RI.Mxx | 30 - 80 mm | 29219.RI.lxx | 1 3/16" - 3 1/4" |

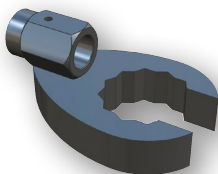

| | | | |
|--------------|------------------------------|--------------|--------------------------------|
| 8 | FLARE OFFSET METRIC 22 mm | 8 | FLARE OFFSET IMPERIAL 22 mm |
| 29219.FO.Mxx | 30 - 80 mm | 29219.FO.lxx | 1 3/16" - 3 1/4" |

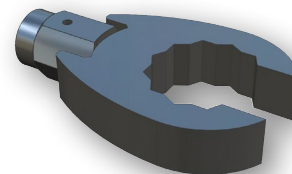

| | | | |
|--------------|------------------------------|--------------|--------------------------------|
| 8 | FLARE INLINE METRIC 22 mm | 8 | FLARE INLINE IMPERIAL 22 mm |
| 29219.FI.Mxx | 30 - 80 mm | 29219.FI.lxx | 1 3/16" - 3 1/4" |

IMPERIAL

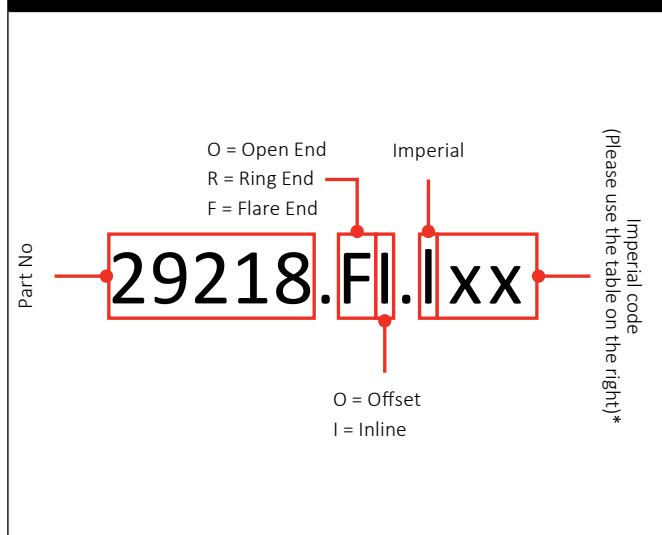

| IMPERIAL A/F | CODE | IMPERIAL A/F | CODE | IMPERIAL A/F | CODE |
|--------------|------|--------------|------|--------------|------|
| 1 3/16" | 19 | 1 15/16" | 31 | 2 11/16" | 43 |
| 1 1/4" | 20 | 2" | 32 | 2 3/4" | 44 |
| 1 5/16" | 21 | 2 1/16" | 33 | 2 13/16" | 45 |
| 1 3/8" | 22 | 2 1/8" | 34 | 2 7/8" | 46 |
| 1 7/16" | 23 | 2 3/16" | 35 | 2 15/16" | 47 |
| 1 1/2" | 24 | 2 1/4" | 36 | 3" | 48 |
| 1 9/16" | 25 | 2 5/16" | 37 | 3 1/16" | 49 |
| 1 5/8" | 26 | 2 3/8" | 38 | 3 1/8" | 50 |
| 1 11/16" | 27 | 2 7/16" | 39 | 3 3/16" | 51 |
| 1 3/4" | 28 | 2 1/2" | 40 | 3 1/4" | 52 |
| 1 13/16" | 29 | 2 9/16" | 41 | | |
| 1 7/8" | 30 | 2 5/8" | 42 | | |

*Example: 1 7/8" open end inline for 22 mm spigot = 29219.OI.I30

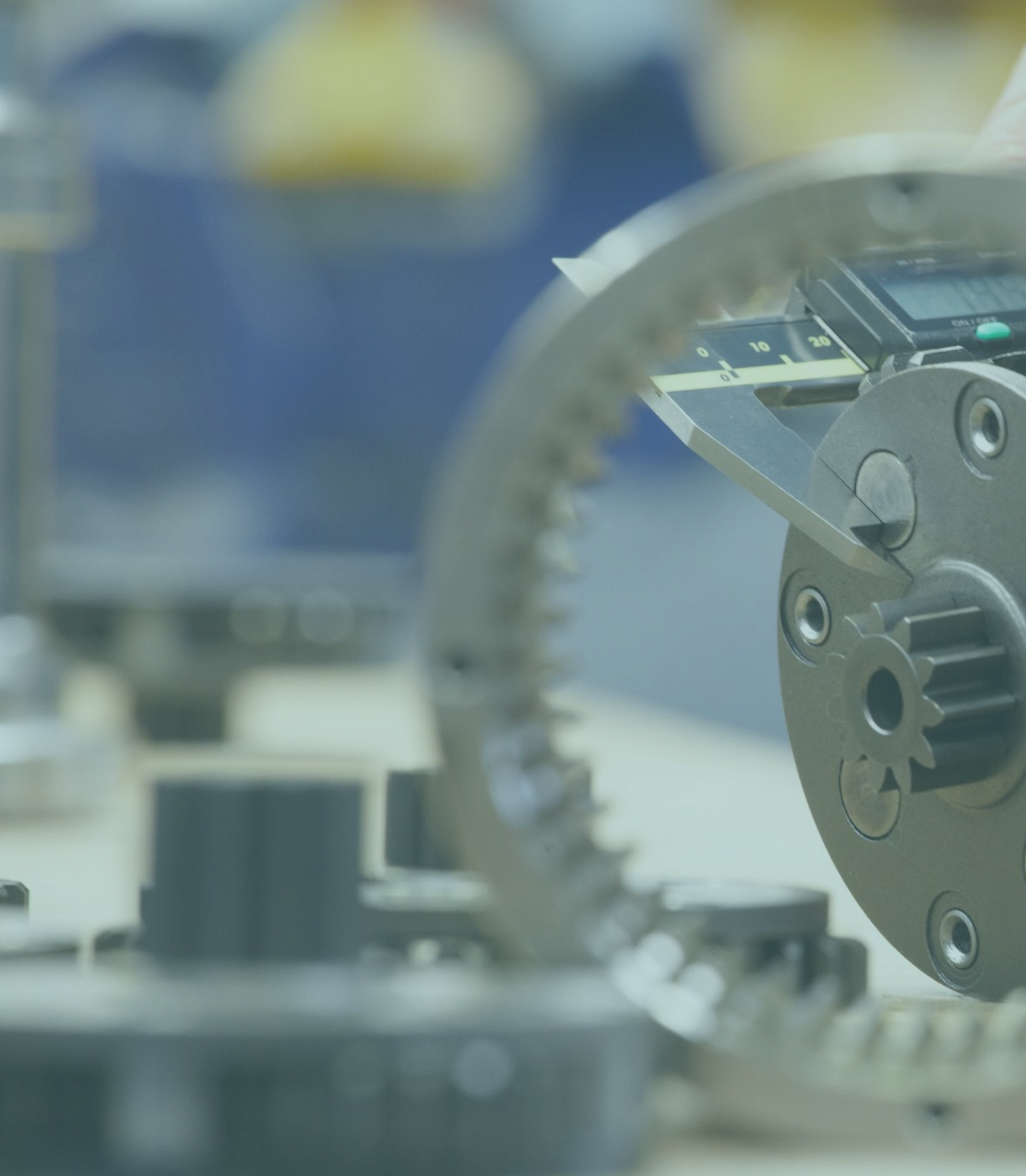



HANDTORQUE® TORQUE MULTIPLIERS



HandTorque® Torque Multipliers 42
 Anti Wind-Up Ratchets (AWUR) 43
 HandTorque® HT3-1000 44
 HandTorque® HT3 Series 44
 HandTorque® HT4 Series 45
 HandTorque® Standard Series 46
 UKAS Accredited Calibration Certification 47
 HandTorque® Compact Series 48

Torque wrench design offers just two solutions to the challenge of applying higher torques: either the load at the handle must be higher or the lever length must be greater. Clearly there are practical and safety limits to both of these solutions.

Norbar's solution is to use a compact, epicyclic gearbox called a HandTorque® multiplier to accurately multiply the input torque provided by a torque wrench by a fixed ratio.



HANDTORQUE® TORQUE MULTIPLIERS

What is a Torque Multiplier?

A torque multiplier is a device that increases the torque that can be applied by an operator. This is because the power output cannot exceed the power input, the number of output revolutions will be lower than the number of input revolutions (Torque x rpm = Power).

How HandTorque® Torque Multipliers Work

HandTorque® multipliers incorporate an 'epicyclic' or 'planetary' gear train having one or more stages. Each stage of gearing increases the torque applied, allowing Norbar to offer multipliers typically in ratios of 5:1, 27:1 and 135:1.

In the planetary gear system, torque is applied to the input gear or 'sun' gear. Three or four planet gears whose teeth are engaged with the 'sun' gear therefore rotate. The outside casing of the multiplier, or 'annulus' is also engaged with the planet gear teeth, and would normally rotate in the opposite direction to the 'sun' gear. A reaction arm prevents the annulus from rotating, and this causes the planet gears to orbit around the 'sun'. The planet gears are held in a 'planetary' carrier which also holds the output square drive, therefore as the planet gears orbit around the sun gear, the carrier and so the square drive turns. Without the reaction arm to keep the annulus stationary, the output square will not apply torque.

No gearbox is 100% efficient, and so the velocity ratio (the number of turns that the input has to make to achieve one revolution of the output) is not the same as the torque multiplication ratio. Norbar multipliers are engineered such that each gear stage typically has a nominal 5:1 ratio, this means a velocity ratio of typically 5.45:1 which results in a true torque multiplication factor of 5.2:1.

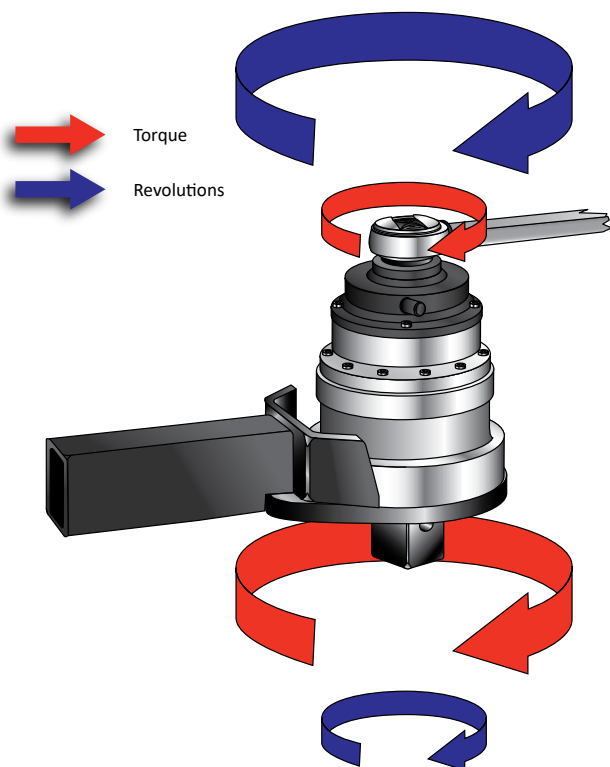

Why use a HandTorque® Multiplier?

- **Safety** – use of long levers can be dangerous. Torque multipliers allow for a reduction in the lever length or operator effort
- **Space limitation** – the use of a long lever may be impossible due to the available space
- **Accuracy** – torque will be applied most accurately when it is applied smoothly and slowly. Torque multipliers enable this by removing much of the physical effort from the tightening task

Advantages of the Norbar HandTorque® System

Norbar gearboxes are built to an extremely high standard of precision. All gears rotate on needle roller bearings about hardened and ground journal pins. As a result, Norbar HandTorques can be relied upon to have a mean torque multiplication accuracy of ±4%, taking the uncertainty out of high torque tightening.

Summary of Norbar torque multiplier advantages:

- The ratio stated is the mean torque multiplication factor
- No correction charts are needed to determine torque output
- Strong, safe Anti Wind-Up Ratchet available on most models for safe and comfortable operation
- A wide range of alternative reaction styles are available making the HandTorque® adaptable to many applications
- Electronic torque transducers are available on most models for precise torque control
- Compact Series are supplied with their own unique calibration certificate allowing the accurate calculation of input torque for critical applications

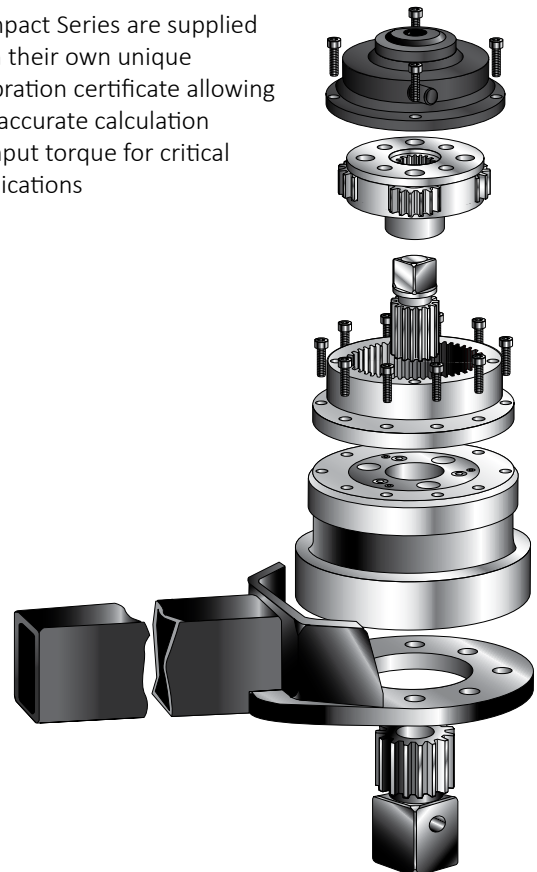



ANTI WIND-UP RATCHETS (AWUR)



Norbar Anti Wind-Up Ratchets (AWUR)

Most multipliers with ratios of 15:1 and over are fitted with an Anti Wind-Up Ratchet. The multiplier can be thought of as a spring which must be fully wound before any tightening/untightening work can be applied to the bolt.

The AWUR ensures that the 'spring' stays wound and that any further torque input to the multiplier is applied directly to the bolt.

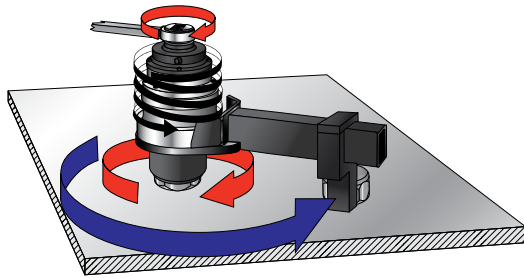

Multiplier behaves like a very stiff 'spring'

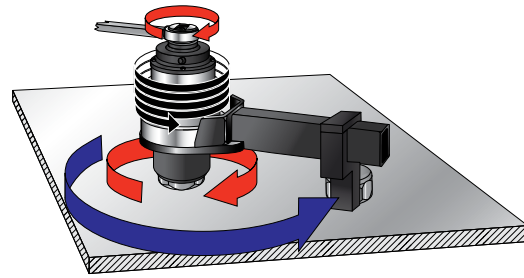

Multiplier will achieve maximum torque only after the 'spring' has been taken up



AWUR benefits include:

1. The torque input device cannot fly backwards against the direction of operation if it is suddenly released.
2. Without an Anti Wind-Up Ratchet, it will often be necessary to continue to make 360° sweeps with the torque input device otherwise the multiplier will 'unwind'. However, obstructions will often make this impossible (as demonstrated in this example).

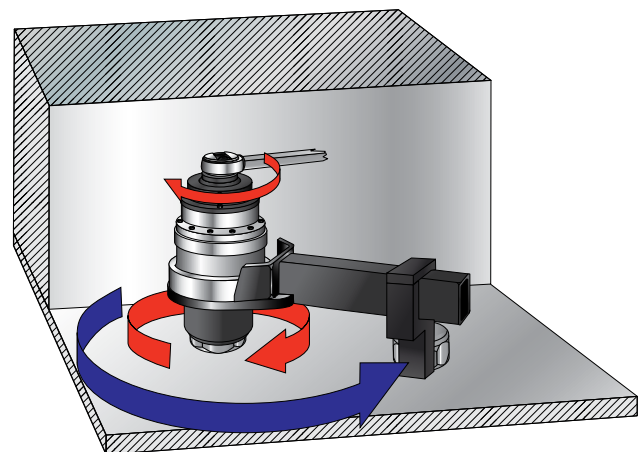

AWUR set to counter-clockwise operation



AWUR set to neutral



AWUR set to clockwise operation



HANDTORQUE® HT3-1000



- 5:1 nominal torque multiplication, reaction dependant. Mean ratio with cranked foot is 4.8:1; with straight reaction is 4.9:1
- ±4% mean torque multiplication accuracy
- Small and compact design
- Updated aesthetics with tough silver metallic powder coat
- Supplied with 2 reaction bar styles for maximum versatility
- Quick-change cranked reaction with improved flexibility allowing reaction in 8 orientations
- Robust construction means minimal maintenance and long life
- If calibration is required, a UKAS accredited calibration certificate may be ordered (at extra cost)

| | |
|--------|---|
| 2 | HT3-1000 |
| 180260 | HT3-1000, 1,000 N·m Kit, ½" input x ¾" output |

HANDTORQUE® HT3 SERIES



- 5:1 mean torque multiplication, accuracy ±4%
- Supplied with two reaction bar styles for maximum versatility
- Robust construction means minimal maintenance and long life
- Supplied in a carry case, the Highwayman is ideal for inclusion in the heavy vehicle tool kit
- 1,300 N·m version has a spare ¾" output square included in the kit
- Multiplier head only (no reaction bars or plastic box) also available
- 1,300 N·m version, part no. 17218
- 2,700 N·m version, part no. 17219
- If calibration is required, a UKAS accredited calibration certificate may be ordered (at extra cost)

| | |
|-------|---|
| 2 | HT3 SERIES |
| 17220 | HT3 1,300 N·m Kit, ½" input x ¾" output |
| 17221 | HT3 2,700 N·m Kit, ¾" input x 1" output |

Kits are supplied in a carry case with a reaction bar and a reaction foot (17220 also contains a spare ¾" sq. dr.)

| Model | | HT3-1000 | HT3 1,300 N·m | HT3 2,700 N·m |
|---------------------------|------------------------|----------|---------------|---------------|
| Part Number | | 180260 | 17220 | 17221 |
| Mean Multiplication Ratio | Nominal | 5:1 | 5:1 | 5:1 |
| | With Cranked Reaction | 4.8:1 | 4.75:1 | 4.75:1 |
| | With Straight Reaction | 4.9:1 | 5:1 | 5:1 |
| Dimensions (mm) | ∅D | 65 | 108 | 108 |
| | H1 | 63 | 103 | 100 |
| | H2 | 21 | 44 | 36 |
| | L | 273 | 398 | 398 |
| | R1 | 55 | 77 | 85 |
| | R2 min. | 83 | 140 | 140 |
| | R2 max. | 143 | 212 | 212 |
| | R3 max. | 240 | 344 | 344 |
| Tool Weight (kg) | | 1.5 | 3.8 | 3.8 |
| Reaction Weight (kg) | Cranked | 0.5 | 1.36 | 1.36 |
| | Straight | 0.7 | 1.1 | 1.1 |

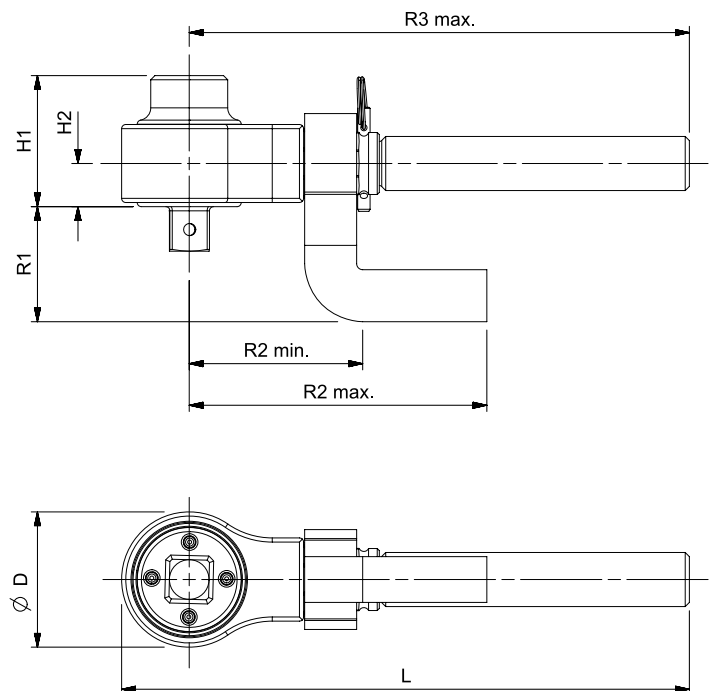

HT3 1300/2700 on right shown in comparison with HT3 1000



HANDTORQUE® HT4 SERIES



- Robust construction means minimal maintenance and long life
- Mean 15.5:1 (3,000 N·m) or 26:1 (4,500 N·m) torque multiplication, accuracy ±4%
- High ratios allow the use of a small torque wrench
- Supplied in carrying case with replacement square drive
- Anti Wind-Up Ratchet fitted to allow safer and more practical operation
- Angle protractor for easy torque and angle tightening
- If calibration is required, a UKAS accredited calibration certificate may be ordered (at extra cost)

| 4 | HT4 SERIES |
|-------|-----------------------------------|
| 17022 | HT4 AWUR, 3,000 N·m, ½" in 1" out |
| 17021 | HT4 AWUR, 4,500 N·m, ½" in 1" out |



| Model | HT4/15.5 AWUR | HT4/26 AWUR | |
|---------------------------|---------------|-------------|-----|
| Part Number | 17022 | 17021 | |
| Mean Multiplication Ratio | 15.5:1 | 26:1 | |
| Dimensions (mm) | ØD | 108 | 108 |
| | H1 | 131 | 149 |
| | H2 | 55 | 55 |
| | L | 498 | 498 |
| | R max. | 444 | 444 |
| Tool Weight (kg) | 6.1 | 7.0 | |
| Reaction Weight (kg) | 1.9 | 1.9 | |

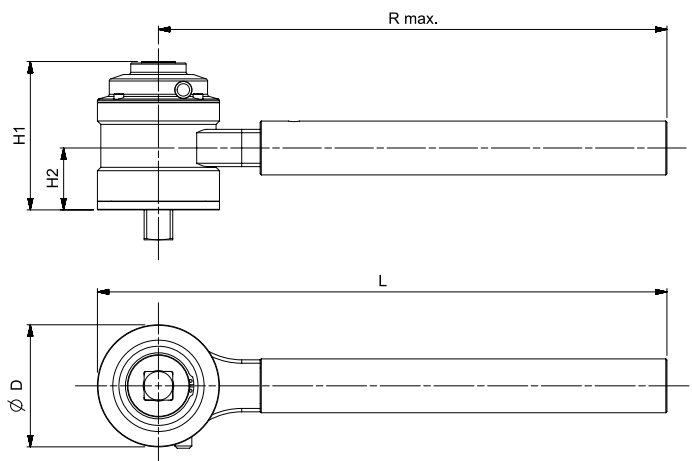



HANDTORQUE® STANDARD SERIES



HT 5/25

- Mean torque multiplication accuracy $\pm 4\%$
- High ratios allow the use of a small torque wrench, multipliers can be used where access is limited
- Anti Wind-Up Ratchet available on high ratio models
- Other reaction styles can be designed to suit specific applications
- Electronic torque transducers can be fitted for precise torque monitoring, see pages 93-95
- Other models available up to 300,000 N·m
- If calibration is required, a UKAS accredited calibration certificate may be ordered (at extra cost) up to 6,000 N·m

| 4 | STANDARD SERIES |
|----------|---|
| 16010 | HT 1/5.2, 1,700 N·m, ½" in ¾" out |
| 16012.HD | HT 2/5.2, 1,700 N·m, ¾" in 1" out |
| 16034.HD | HT 2/27, 1,700 N·m, ½" in 1" out |
| 16089.HD | HT 2/27 AWUR, 1,700 N·m, ½" in 1" out |
| 16014 | HT 5/5.2, 3,400 N·m, ¾" in 1" out |
| 16028 | HT 5/27, 3,400 N·m, ½" in 1" out |
| 16090 | HT 5/27 AWUR, 3,400 N·m, ½" in 1" out |
| 16016 | HT 6/5.2, 3,400 N·m, ¾" in 1½" out |
| 16024 | HT 6/27, 3,400 N·m, ½" in 1½" out |
| 16092 | HT 6/27 AWUR, 3,400 N·m, ½" in 1½" out |
| 16093 | HT 6/135 AWUR, 3,400 N·m, ½" in 1½" out |
| 16067 | HT 7/5.2, 6,000 N·m, ¾" in 1½" out |
| 16018 | HT 7/27, 6,000 N·m, ½" in 1½" out |
| 16065 | HT 7/27 AWUR, 6,000 N·m, ½" in 1½" out |
| 16068 | HT 7/135 AWUR, 6,000 N·m, ½" in 1½" out |
| 16059 | HT 9/27, 9,500 N·m, ¾" in 1½" out |
| 16070 | HT 9/27 AWUR, 9,500 N·m, ¾" in 1½" out |
| 16071 | HT 9/135 AWUR, 9,500 N·m, ½" in 1½" out |
| 16082 | HT 11/27, 20,000 N·m, ¾" in 2½" out |
| 16049 | HT 11/135 AWUR, 20,000 N·m, ½" in 2½" out |
| 16053 | HT 13/135 AWUR, 47,500 N·m, ½" in 2½" out |

Other gear ratios may be available upon request.

If AWUR is not required please enquire for part number.

HT 13/135 fitted with weld prepared reaction ring as standard.

AWUR = Anti Wind-Up Ratchet. See page 43.

NOTE: Model name does not reflect multiplication ratios, see mean multiplication ratios below.

For spares kits for Norbar multipliers, please see page 134.

| Model | HT 1/5.2 | HT 2/5.2 | HT 2/27 | HT 2/27 AWUR | HT 5/5.2 | HT 5/27 | HT 5/27 AWUR | HT 6/5.2 | HT 6/27 | HT 6/27 AWUR | HT 6/135 AWUR |
|---------------------------|----------|----------|----------|--------------|----------|---------|--------------|----------|---------|--------------|---------------|
| Part Number | 16010 | 16012.HD | 16034.HD | 16089.HD | 16014 | 16028 | 16090 | 16016 | 16024 | 16092 | 16093 |
| Mean Multiplication Ratio | 5.2:1 | 5.2:1 | 27:1 | 27:1 | 5.2:1 | 27:1 | 27:1 | 5.2:1 | 27:1 | 27:1 | 135:1 |
| Dimensions (mm) | ØD | 108 | 108 | 108 | 119 | 119 | 119 | 119 | 119 | 119 | 119 |
| | H | 83 | 98 | 98 | 114 | 106 | 127 | 132 | 106 | 128 | 159 |
| | L | 303 | 303 | 303 | 303 | 355 | 355 | 355 | 355 | 355 | 355 |
| | R1 | N/A | N/A | N/A | N/A | N/A | N/A | N/A | N/A | N/A | N/A |
| | R2 min. | 83 | 83 | 83 | 83 | 86 | 86 | 86 | 86 | 86 | 86 |
| R2 max. | 216 | 216 | 216 | 216 | 263 | 263 | 263 | 263 | 263 | 263 | |
| Tool Weight (kg) | 3.0 | 3.2 | 4.6 | 6.7 | 4.7 | 6.4 | 7.5 | 4.7 | 6.4 | 7.5 | 9.0 |
| Reaction Weight (kg) | 2.2 | 2.2 | 2.2 | 2.2 | 2.5 | 2.5 | 2.5 | 2.5 | 2.5 | 2.5 | 2.5 |

| Model | HT 7/5.2 | HT 7/27 | HT 7/27 AWUR | HT 7/135 AWUR | HT 9/27 | HT 9/27 AWUR | HT 9/135 AWUR | HT 11/27 | HT 11/135 AWUR | HT 13/135 AWUR |
|---------------------------|----------|---------|--------------|---------------|---------|--------------|---------------|----------|----------------|----------------|
| Part Number | 16067 | 16018 | 16065 | 16068 | 16059 | 16070 | 16071 | 16082 | 16049 | 16053 |
| Mean Multiplication Ratio | 5.2:1 | 27:1 | 27:1 | 135:1 | 27:1 | 27:1 | 135:1 | 27:1 | 135:1 | 135:1 |
| Dimensions (mm) | ØD | 144 | 144 | 144 | 184 | 184 | 184 | 212 | 212 | 315 |
| | H | 136 | 157 | 162 | 188 | 166 | 162 | 182 | 208 | 322 |
| | L | 423 | 423 | 423 | 423 | 448 | 448 | 448 | 609 | 341 |
| | R1 | 84 | 84 | 84 | 84 | 84 | 84 | 84 | N/A | N/A |
| | R2 min. | 150 | 150 | 150 | 150 | 175 | 175 | 175 | 320 | N/A |
| R2 max. | 331 | 331 | 331 | 331 | 351 | 351 | 351 | 500 | 500 | |
| Tool Weight (kg) | 8.1 | 9.6 | 10.7 | 12.2 | 16.3 | 17.4 | 18.9 | 31.7 | 32.1 | 95.2 |
| Reaction Weight (kg) | 6.3 | 6.3 | 6.3 | 6.3 | 8.3 | 8.3 | 8.3 | 13.3 | 13.3 | 6.9 |



HANDTORQUE® STANDARD SERIES

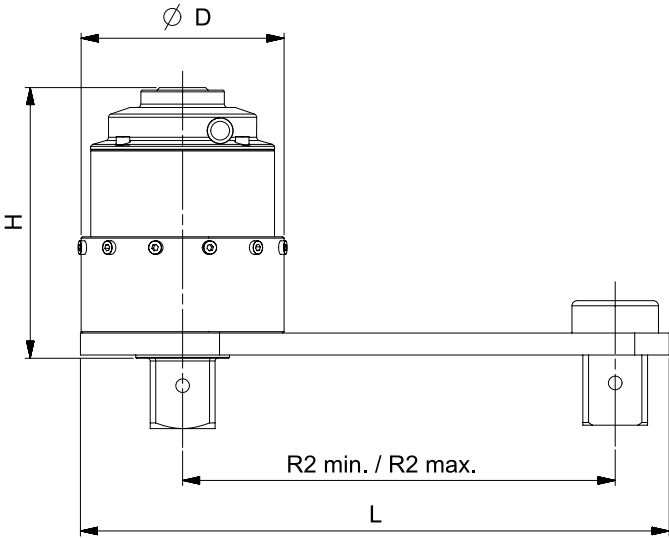

HT 1 - HT 6

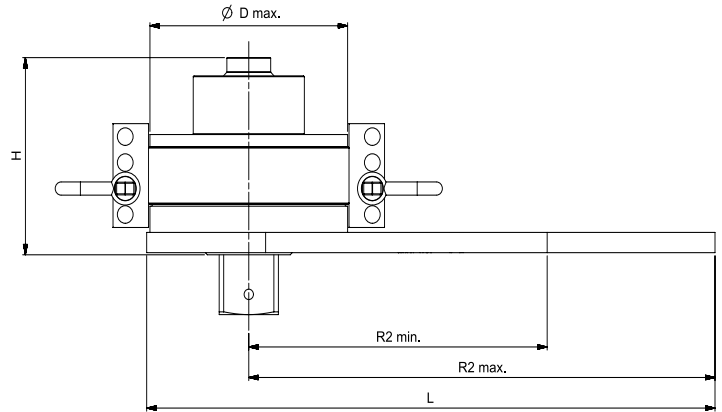

HT 11

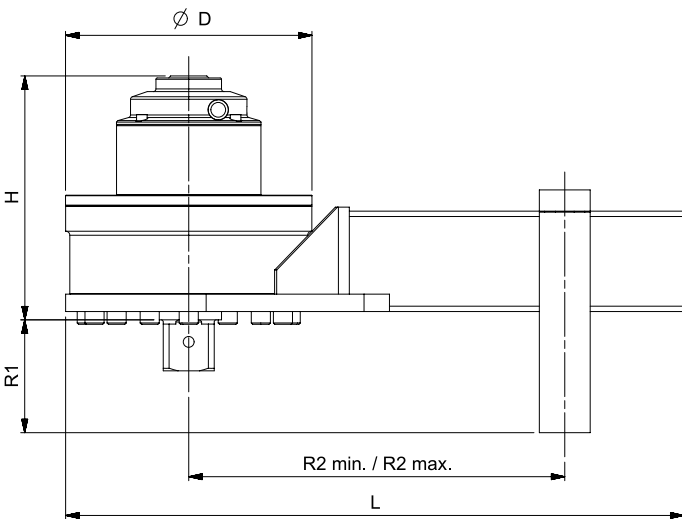

HT 7 - HT 9

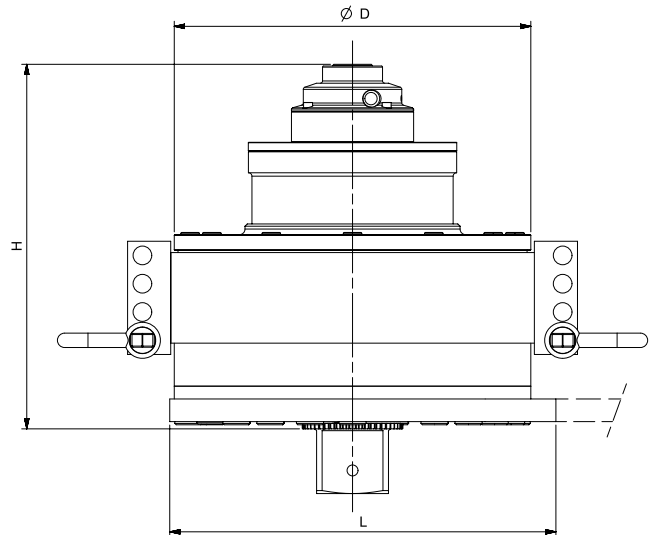

HT 13

UKAS ACCREDITED CALIBRATION CERTIFICATION

The part numbers shown below are for 'As Found', for new manual torque multiplying gearboxes up to the maximum capacity shown.

| | |
|--------------|--------------------------------|
| 12 | ONE DIRECTION |
| HTCC2.CW | Up to 6,000 N·m / 5,000 lbf·ft |
| 12 | TWO DIRECTIONS |
| HTCC2.CW+CCW | Up to 6,000 N·m / 5,000 lbf·ft |





HANDTORQUE® COMPACT SERIES



HT-72/27 (181450)

- Compact dimensions allow excellent access to applications and easy, safe handling
- Lightweight for torque capacity
- Supplied as standard with a steel reaction arm. Other options are available on request, including customised reactions
- Mean torque multiplication accuracy $\pm 4\%$
- Robust, 48 tooth Anti Wind-Up Ratchet (AWUR) contains the forces generated during tightening for safe and easy operation
- Each multiplier is supplied with its own unique traceable calibration certificate allowing the accurate calculation of input torque for critical applications
- If you order a UKAS accredited calibration certificate (available at extra cost), this certificate will be provided in place of the traceable calibration certificate.

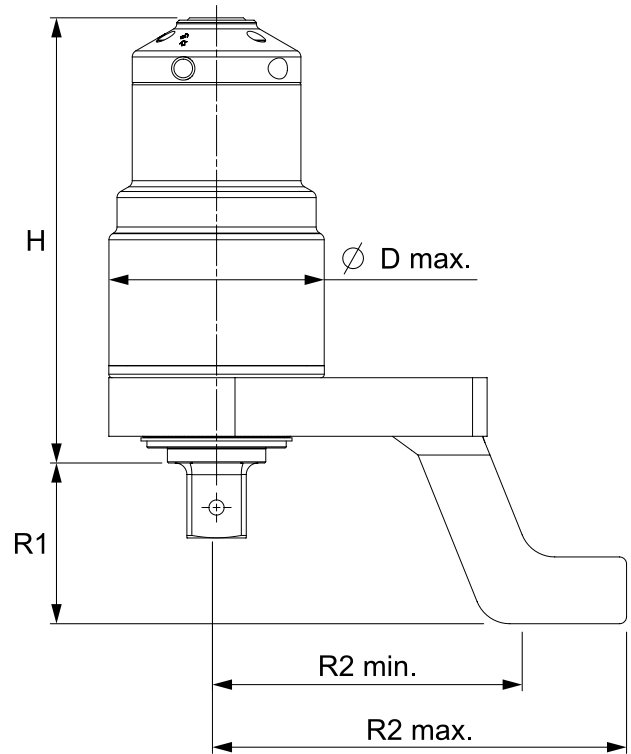

| 4 | COMPACT SERIES |
|--------|--|
| 181440 | HT-52/4.7, 1,000 N·m, ½" in ¾" out |
| 181441 | HT-52/22.2, 1,000 N·m, ¾" in ¾" out |
| 181442 | HT-52/22.2, 1,000 N·m, ½" in ¾" out |
| 181443 | HT-52/22.2 AWUR, 1,000 N·m, ¾" in ¾" out |
| 181444 | HT-52/22.2 AWUR, 1,000 N·m, ½" in ¾" out |
| 181445 | HT-52/22.2 AWUR, 1,000 N·m, ¾" in 1" out |
| 181446 | HT-52/22.2 AWUR, 1,000 N·m, ½" in 1" out |
| 181447 | HT-72/5.2, 1,500 N·m, ½" in 1" out |
| 181448 | HT-72/5.2, 1,000 N·m, ¾" in ¾" out |
| 181449 | HT-72/5.2, 2,000 N·m, ¾" in 1" out |
| 181450 | HT-72/27, 2,000 N·m, ½" in 1" out |
| 181451 | HT-72/27 AWUR, 2,000 N·m, ½" in 1" out |
| 181452 | HT-92/25 AWUR, 4,000 N·m, ½" in 1" out |
| 181453 | HT-119/25.5 AWUR, 7,000 N·m, ½" in 1½" out |

| Model | HT-52/4.7 | HT-52/22.2 | HT-52/22.2 AWUR | HT-72/5.2 | HT-72/5.2 | HT-72/5.2 | HT-72/27 | HT-72/27 AWUR | HT-92/25 AWUR | HT-119/25.5 AWUR |
|---------------------------|-----------|------------------|--------------------------------------|-----------|-----------|-----------|----------|---------------|---------------|------------------|
| Part Number | 181440 | 181441 181442 | 181443 181444 181445 181446 | 181447 | 181448 | 181449 | 181450 | 181451 | 181452 | 181453 |
| Mean Multiplication Ratio | 4.7:1 | 22.2:1 | 22.2:1 | 5.2:1 | 5.2:1 | 5.2:1 | 27:1 | 27:1 | 25:1 | 25.5:1 |
| Dimensions (mm) | ØD max. | 52 | 52 | 72 | 72 | 72 | 72 | 72 | 92 | 119 |
| | H | 91 | 116 | 130 | 117 | 122 | 117 | 132 | 150 | 212 |
| | R1 | 58 | 58 | 58 | 74 | 69 | 74 | 74 | 69 | 91 |
| | R2 min. | 71 | 71 | 71 | 112 | 112 | 112 | 112 | 115 | 152 |
| | R2 max. | 131 | 131 | 131 | 165 | 165 | 165 | 165 | 175 | 212 |
| Tool Weight (kg) | 1.0 | 1.3 | 1.4 | 2.5 | 2.5 | 2.6 | 2.9 | 3.2 | 5.4 | 9.3 |
| Reaction Weight (kg) | 0.9 | 0.9 | 0.9 | 1.4 | 1.4 | 1.4 | 1.4 | 1.4 | 2.5 | 4.0 |



POWERED TORQUE TOOLS

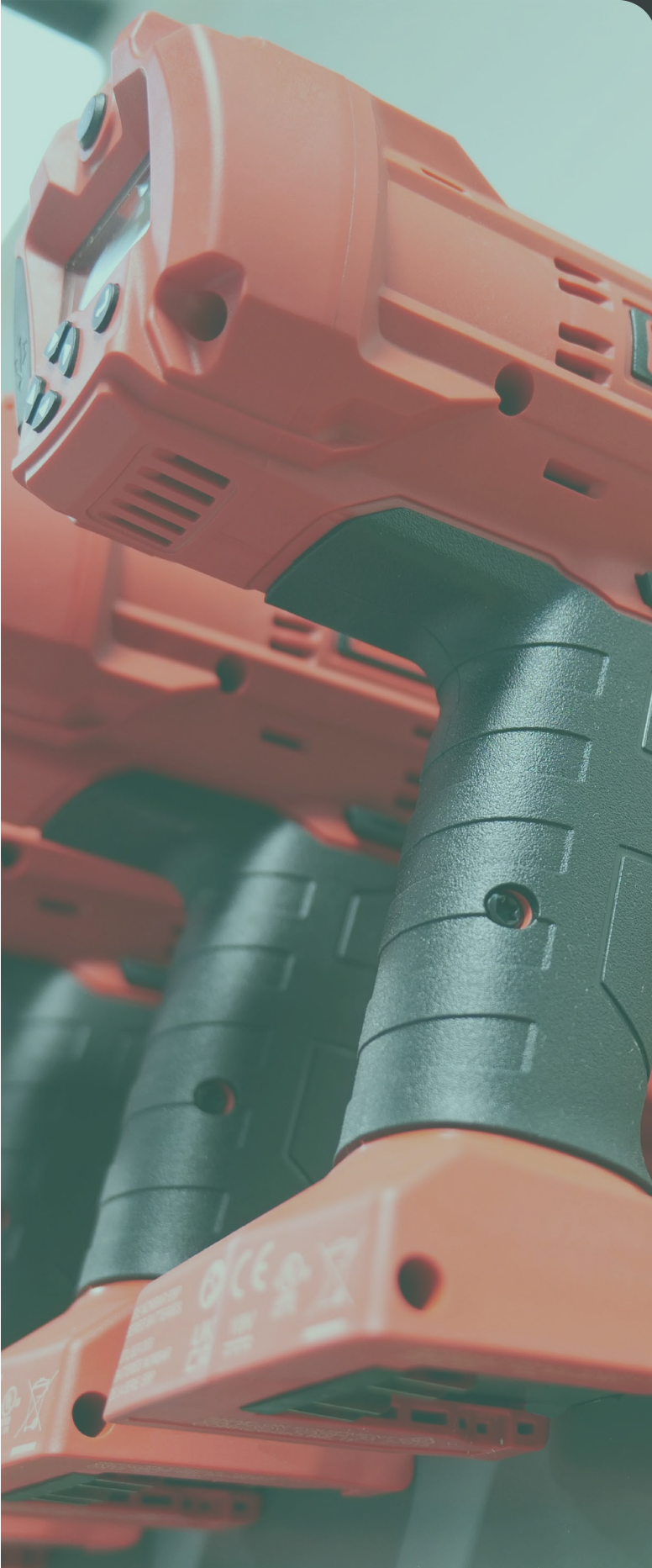

- EvoTorque® Battery Tool Compact (EBT-C) 50
- EvoTorque® Battery Tool Compact Advanced (EBT-CA) 51
- EvoTorque® Battery Tool (EBT) 54
- EvoTorque®2 56
- Pneumatic Torque Tools 58
- PneuTorque® PTS™ Series 60
- PneuTorque® PTS™ Remote Series 62
- ET, ET2, PTS™ and PTM Nose Extensions 63
- PneuTorque® Standard Series 64
- Torque Reaction 68
- PTS™ and PTM Dual Trigger Module (DTM) 72
- Secondary Handle 72
- Right Angle Gearbox Module 72
- Lubro Control Units 74
- Socket Retainers 74

Electronic Tools

EvoTorque® are electronic torque tools designed for applying torque to threaded fasteners. The unique ‘Intelligent Joint Sensing’ technology will accurately tighten to the correct torque without the risk of excess overshoot or undershoot that is common in other electric tools.

Pneumatic Tools

PneuTorques consist of a robust air motor driving a Norbar multiplier with three or more stages of epicyclic gearing. This gives the advantage of smooth, continuous rotation (versus an impulsing action or the hammer action in an impacting tool).



EVO TORQUE® BATTERY TOOL COMPACT (EBT-C)



Discover the Evolution

The EvoTorque® Battery Tool Compact (EBT-C) is setting new standards in the torque multiplier market.

Experience the blend of compact design, precise torque measurement and exceptional thermal management that makes the EBT-C the tool of choice for those who refuse to compromise on safety and reliability.



More than...

20%

smaller than equivalent EBT models



- The compact, lightweight and ergonomic design allows for easier access to applications and improved operator grip and comfort
- Patented cooling system, specifically engineered to manage and dissipate heat efficiently during operation ensures that the tool remains at optimal operating temperatures, even under heavy use
- Patented transducer-controlled battery torque tool works with 'intelligent joint sensing' technology to provide high accuracy and repeatability across all joint types
- The 'Safe to Start' button enhances safety by preventing accidental activation, requiring intentional engagement to proceed. Users can disable this feature in the menu settings for flexibility and personal preference
- 18V, 5.0Ah battery and efficient motor give outstanding fastening performance per charge
- High powered LED to illuminate application



EVOTORQUE® BATTERY TOOL COMPACT ADVANCED (EBT-CA)



Data you can Trust

The EvoTorque® Battery Tool Compact Advanced (EBT-CA) shares all the features and benefits of the EBT-C but has the premium additions of communication and data functionality.

| | EBT-C | EBT-CA |
|--------------------------------|-------|--------|
| Accuracy | ± 5 % | ± 3 % |
| Comms | □ | ■ |
| Presets | 10 | 50 |
| Torque Mode | ■ | ■ |
| Torque Then Angle Mode | ■ | ■ |
| Angle Mode | □ | ■ |
| Torque and Angle Monitoring | □ | ■ |
| Audit Mode | □ | ■ |
| Result Storage | □ | ■ |
| User ID | □ | ■ |
| PC Software | □ | ■ |
| Phone App | □ | ■ |
| Job Presets | □ | ■ |
| External Gearbox Ratio Setting | □ | ■ |
| Tool Lock Modes | □ | ■ |

EBT-CA Torque Modes

Torque
Operator sets a torque value and the tool will tighten until the target torque is achieved.



Torque Then Angle
Operator sets an initial torque target and final angle value. The tool will tighten to the set torque target, and then apply the angle value. The final torque value after the angle has been applied will be displayed.



Angle Only (Optional Torque Limit)
Operator sets an angle target, and the tool will immediately rotate until that angle is achieved. Torque is monitored, and a torque limit can be set which the tool will not exceed.

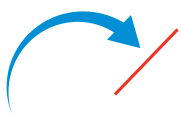





Torque with Angle Monitoring (TAM)
Operator sets an Initial and Final Torque, the angle is monitored between the Initial and Final Torque.



Audit Mode
The Operator sets a target torque and an angle limit. The tool will tighten until the target torque is achieved. The fastener rotation is measured, a pass/fail is then indicated.



| Symbol Key | |
|---|---|
| □ | ■ |
| Not Included Features | Included Features |
|  |  |
| Torque | Angle |
|  |  |
| Torque Monitoring | Angle Monitoring |
|  | |
| Torque Limit | |

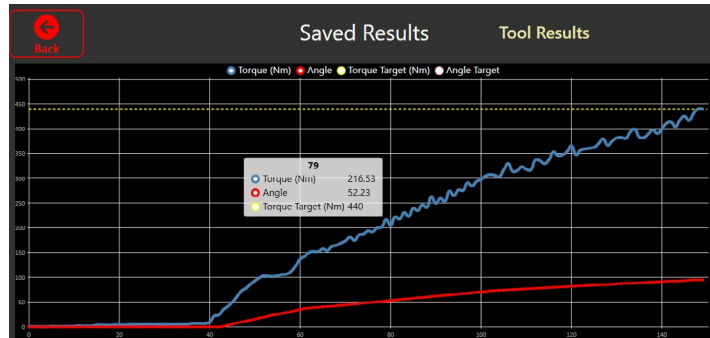

Software Graph

The tool comes supplied with PC software and a mobile phone app is also available. These can be used to retrieve results, view tool diagnostics, configure Presets, User IDs and Job Presets.

- Connectivity Options**
 Connect to mobile app using Bluetooth® Low Energy (BLE)
 Connect to PC software via USB
 Connect to G400 or CTech Box systems with XBEE
 (Please see pages 76- 77 for more information on Connected Tools)
- Create and send Presets**
 The user can create individual Presets, these can be grouped together in Jobs. Each Job can hold up to 50 Presets. Jobs and/or Presets can be transmitted to the tool, and results recorded.
- Create and send Users**
 Set up and send User IDs, with full name and tool access password.
- Save Results**
 The user can download results and graphs to a database in either the PC software or mobile app.
- Viewing Downloaded Results**
 The results include the tool serial number, timestamp, checkmarks of whether the result achieved the correct torque and angle values. These can be viewed in either table or graph format, and exported as CSV files.



| 13 | EBT-C SERIES |
|--------|---|
| 181473 | ¾" sq. dr., 150 - 750 N·m, 110 - 550 lbf·ft |
| 181477 | 1" sq. dr., 220 - 1,100 N·m, 160 - 800 lbf·ft |

| 8 | EBT-C & EBT-CA SERIES - ACCESSORIES |
|-----------|-------------------------------------|
| 60334.EBT | Battery Pack |
| 60352.KIT | Single Bay Battery Charger |
| 19868 | ¾" sq. dr for EBT-C 1,100 |

| 13 | EBT-CA SERIES NON - WIRELESS |
|--------|---|
| 181474 | ¾" sq. dr., 150 - 750 N·m, 110 - 550 lbf·ft |
| 181478 | 1" sq. dr., 220 - 1,100 N·m, 160 - 800 lbf·ft |

| 13 | EBT-CA SERIES BLUETOOTH |
|--------|---|
| 181475 | ¾" sq. dr., 150 - 750 N·m, 110 - 550 lbf·ft |
| 181479 | 1" sq. dr., 220 - 1,100 N·m, 160 - 800 lbf·ft |

| 13 | EBT-CA SERIES G400 |
|--------|---|
| 181476 | ¾" sq. dr., 150 - 750 N·m, 110 - 550 lbf·ft |
| 181480 | 1" sq. dr., 220 - 1,100 N·m, 160 - 800 lbf·ft |

| Model | EBT-C-750 EBT-CA-750 | EBT-C-1100 EBT-CA-1100 |
|------------------------|--------------------------------------|--------------------------------------|
| Part Number | 181473 181474 181475 181476 | 181477 181478 181479 181480 |
| Operating Range (N·m) | 75 - 750 | 110 - 1,100 |
| Calibrated Range (N·m) | 150 - 750 | 220 - 1,100 |
| Output Speed (rpm) | 12.5 | 9.1 |
| Dimensions (mm) | ØD max. | 60 |
| | H1 | 39 |
| | H2 | 224 |
| | L | 282 |
| | R1 | 60 |
| | R2 min. | 71 |
| | R2 max. | 131 |
| W | 76 | |
| Tool Weight (kg)** | 3.1 | 3.8 |
| Reaction Weight (kg) | 0.8 | 1.4 |



** Tool weight excludes both reaction and battery.
The battery weighs 0.8 kg.

Tool supplied with a traceable Torque and Angle Certificate of Calibration, 2 batteries, 1 single bay battery charger, cranked reaction, operator's manual and quick reference guide

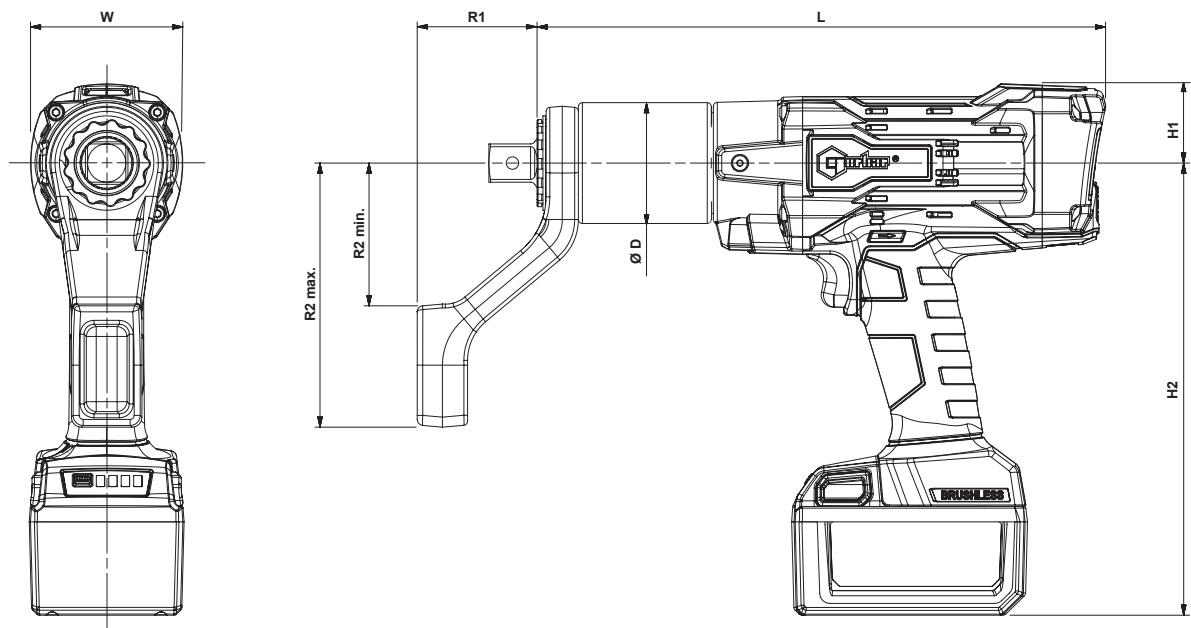



19864

Wheel Reaction Assembly for use with EBT-C & EBT-CA 750



19859

Bladed Reaction for use with EBT-C & EBT-CA 750



EBT-C-750 Series

EBT-C 750 shown with Cranked Reaction (19860)



EBT-C-1100 Series

EBT-C 1100 shown with Cranked Reaction (19861)

| 11 | EBT-C & EBT-CA REACTIONS FOR 750 N·m Tools |
|-----------|--|
| 19859 | Bladed Reaction |
| 19860 | Cranked Reaction |
| 19864 | Wheel Reaction Assembly |
| 19876.006 | 6" Bladed Extension |
| 19876.009 | 9" Bladed Extension |
| 19869 | 6", 3/4" sq. dr. Nose Extension |

Below: 19864 - Wheel Reaction Assembly

Right: 19859 - Bladed Reaction



| 11 | EBT-C & EBT-CA REACTIONS FOR 1,100 N·m Tools |
|-----------|--|
| 19870 | Bladed Reaction |
| 19861 | Cranked Reaction |
| 19872 | Wheel Reaction Assembly |
| 19879.009 | 9" Bladed Extension |

Left to Right:
19611 - Cranked Reaction
19782 - Single Sided Reaction Plate
19783 - Double Sided Reaction Plate
See pages 70 - 71 for more information



NOTE: Existing reactions for 68 mm gearbox will work with EBT-C and EBT-CA 1100
Where a more bespoke reaction is required, our 'Engineer to Order' service is available



EVOTORQUE® BATTERY TOOL (EBT)



The EvoTorque® Battery Tool (EBT) features a new brushless motor, data memory and data transfer capabilities. Norbar has combined this with our respected gearboxes to deliver a range of fast, reliable, accurate torque tools that retain key features from our EvoTorque® 2 range (see page 56).

Fast: EBT uses a powerful motor coupled with either a single speed or auto two speed gearbox for rapid joint completion times.

Durable: The industrial motor used by the EBT gives long life with minimal motor service requirement.

Accurate: EBT is a transducer-controlled battery powered torque tool designed for accurately applying torque to threaded fasteners. The unique 'intelligent joint sensing' technology continually measures the joint during tightening and when necessary, employs dynamic braking to avoid torque over-shoot due to motor inertia. Both accuracy and repeatability of ±3% of the setting within the calibrated range.

- Tool is not constrained by power cable or hose, improving safety, convenience and versatility
- 18V, 5.0Ah battery and efficient motor give outstanding fastening performance per charge
- 'Safe to start' button ensures hands are safely positioned at start up

Note: In some circumstances it can be difficult to support and operate the tool while simultaneously pressing the trigger and 'safe to start' button. For this reason, single trigger models are also available.

- OLED display ensures visibility in all conditions
- High powered LED to illuminate application
- Optional 'Ease of Use' functionality when in 'Torque Only' mode, minimising operator error
- Optional 'Relax Mode' feature automatically reverses tool following joint completion until the tool becomes free or the trigger is released, minimising the chance of fastener and reaction 'locking' in place
- Supplied with a traceable calibration certificate for torque and angle as standard
Calibrated ranges shown in the table on page 55, clockwise only
- Available in single speed ideal for torque with angle control
- Auto two speed configurations available for rapid joint completion
- Torque, Torque & Angle and Torque Audit modes available
- In Torque & Angle Mode and Audit Mode, torque can be set from a lower percentage of tool maximum on single speed tools compared to their auto two speed equivalents. Single speed tools are therefore recommended for angle operation
- Software can be updated remotely, without the need to return the product to Norbar
- Quiet : Noise level : 79.1dB(A), with an uncertainty K = 3dB, when free-running
- Vibration : Does not exceed 2.5m/s² (highest measured under test : 0.9m/s²)



EBT-800 Series



EBT-1350 Series



EBT-2000 Series



EBT-2700 Series



EBT-4000 Series



EBT-7000 Series



EVOTORQUE® BATTERY TOOL (EBT)



| 13 | EBT SERIES - SINGLE SPEED - 'SAFE TO START' MODELS |
|---------|--|
| 180349 | ¾" sq. dr., 160 - 800 N·m, 118 - 600 lbf-ft, Kit |
| 180445* | 1" sq. dr., 200 - 1,350 N·m, 150 - 1,000 lbf-ft, Kit |
| 180493 | 1" sq. dr., 400 - 2,000 N·m, 295 - 1,475 lbf-ft, Kit |
| 180541 | 1" sq. dr., 400 - 2,700 N·m, 295 - 2,000 lbf-ft, Kit |
| 180637 | 1" sq. dr., 800 - 4,000 N·m, 590 - 2,950 lbf-ft, Kit |
| 181481 | 1½" sq. dr., 1,400 - 7,000 N·m, 1,030 - 5,200 lbf-ft, Kit |

| 13 | EBT SERIES - AUTO TWO SPEED - 'SAFE TO START' MODELS |
|---------|---|
| 180469* | 1" sq. dr., 338 - 1,350 N·m, 250 - 1,000 lbf-ft, Kit |
| 180565 | 1" sq. dr., 676 - 2,700 N·m, 499 - 2,000 lbf-ft, Kit |
| 180661 | 1" sq. dr., 1,000 - 4,000 N·m, 738 - 2,950 lbf-ft, Kit |

*1,350 N·m models come supplied with both ¾" and 1" sq. dr.

| 13 | EBT SERIES - SINGLE SPEED - SINGLE TRIGGER MODELS |
|---------|--|
| 180850 | ¾" sq. dr., 160 - 800 N·m, 118 - 600 lbf-ft, Kit |
| 180898* | 1" sq. dr., 200 - 1,350 N·m, 150 - 1,000 lbf-ft, Kit |
| 181305 | 1" sq. dr., 400 - 2,000 N·m, 295 - 1,475 lbf-ft, Kit |
| 180946 | 1" sq. dr., 400 - 2,700 N·m, 295 - 2,000 lbf-ft, Kit |
| 180994 | 1" sq. dr., 800 - 4,000 N·m, 590 - 2,950 lbf-ft, Kit |
| 181482 | 1½" sq. dr., 1,400 - 7,000 N·m, 1,030 - 5,200 lbf-ft, Kit |

| 13 | EBT SERIES - AUTO TWO SPEED - SINGLE TRIGGER MODELS |
|---------|---|
| 180922* | 1" sq. dr., 338 - 1,350 N·m, 250 - 1,000 lbf-ft, Kit |
| 180970 | 1" sq. dr., 676 - 2,700 N·m, 499 - 2,000 lbf-ft, Kit |
| 181018 | 1" sq. dr., 1,000 - 4,000 N·m, 738 - 2,950 lbf-ft, Kit |

| Model | EBT-800 | EBT-1350 | EBT-1350 Auto Two Speed | EBT-2000 | EBT-2700 | EBT-2700 Auto Two Speed | EBT-4000 | EBT-4000 Auto Two Speed | EBT-7000 |
|------------------------|------------------|------------------|-------------------------|------------------|------------------|-------------------------|------------------|-------------------------|------------------|
| Part Number | 180349 180850 | 180445 180898 | 180469 180922 | 180493 181305 | 180541 180946 | 180565 180970 | 180637 180994 | 180661 181018 | 181481 181482 |
| Operating Range (N·m) | 100 - 800 | 120 - 1,350 | 338 - 1,350 | 200 - 2,000 | 270 - 2,700 | 676 - 2,700 | 400 - 4,000 | 1,000 - 4,000 | 1,400 - 7,000 |
| Calibrated Range (N·m) | 160 - 800 | 200 - 1,350 | 338 - 1,350 | 400 - 2,000 | 400 - 2,700 | 676 - 2,700 | 800 - 4,000 | 1,000 - 4,000 | 1,400 - 7,000 |
| Output Speed (rpm) | 11.2 | 6.5 | 32 | 4.2 | 3.3 | 13 | 2.3 | 9.5 | 1.2 |
| Dimensions (mm) | ØD max. | 52 | 72 | 72 | 68 | 80 | 92 | 92 | 119 |
| | H1 | 40 | 40 | 40 | 40 | 40 | 40 | 40 | 40 |
| | H2 | 262 | 262 | 262 | 262 | 262 | 262 | 262 | 262 |
| | L | 271 | 298 | 317 | 294 | 298 | 333 | 352 | 378 |
| | R1 | 59 | 76 | 76 | 75 | 76 | 76 | 70 | 90 |
| | R2 min. | 68 | 124 | 124 | 120 | 124 | 124 | 125 | 160 |
| | R2 max. | 131 | 167 | 167 | 165 | 167 | 167 | 175 | 210 |
| | W | 90 | 90 | 90 | 90 | 90 | 90 | 90 | 90 |
| Tool Weight (kg)* | 3.7 | 5.7 | 5.9 | 4.9 | 5.9 | 6.8 | 7.9 | 8.3 | 13.1 |
| Reaction Weight (kg) | 0.8 | 1.4 | 1.4 | 1.1 | 1.4 | 1.4 | 2.5 | 2.5 | 3.9 |

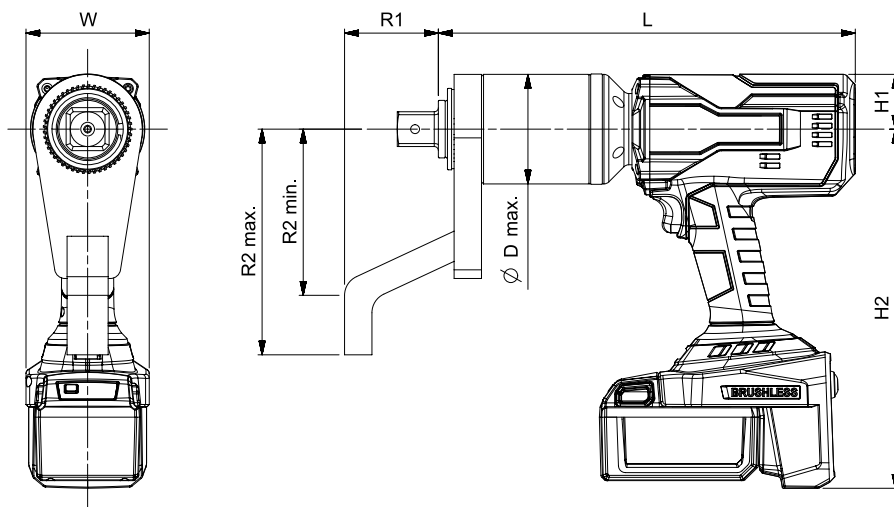

NOTE: Kit versions come with tool, 2 batteries, charger and a secondary handle in a carry case. 800 N·m tools do not come with a secondary handle.

Bare tools are also available, please visit www.norbar.com for more information.

Bare tools are supplied in a cardboard box without batteries, charger and secondary handle. Other tool variations are available, please contact Norbar for details.

NOTE: When the tool is to be used for untightening bolts; Norbar recommends the selection of single speed versions. In the case of prevailing torque lock-nuts or partially tightening bolts, the Auto Two Speed version of the tools will generally give no advantage and single speed tools should be selected.

* Tool weight excludes both reaction and battery. The battery weighs 0.8 kg.

Tool ranges shown above are calibrated ranges, see table above line drawing for operating ranges.

| 8 | EBT SERIES - ACCESSORIES |
|-----------|----------------------------|
| 60334.EBT | Battery Pack |
| 60352.KIT | Single Bay Battery Charger |



EVOTORQUE®2



The EvoTorque®2 is an electronic torque tool designed to accurately apply torque to threaded fasteners. Tools are factory calibrated to $\pm 3\%$ of reading. The unique ‘intelligent joint sensing’ technology continually measures the joint during tightening and when necessary, employs dynamic braking to avoid torque over-shoot due to motor inertia. Consequently, EvoTorque®2 can apply torque accurately over a wide range of joint rates from hard (high torque rate) through to soft (low torque rate). All EvoTorque®2 tools are highly tolerant of supply voltage and frequency variation. If the supply voltage is outside of tolerance then, as a safety feature, the tool will be prevented from starting.

The EvoTorque®2 has the ability to memorise multiple targets, work IDs, user IDs and readings. A work sequence (flow) can be performed on the EvoTorque®2, taking the user through a pre-defined tightening sequence. The tool has four modes of operation: Torque, Torque & Angle, Torque & Angle with Final Torque and Torque Audit. The unique Audit Mode is a sophisticated feature for testing pre-tightened bolts with minimal impact on the original fastening torque and can provide quality control data for monitoring joint performance over time. With accuracy and repeatability of $\pm 3\%$ of the setting, EvoTorque®2 offers many features including:

- Multiple units of torque measurement, N·m, lbf·ft, ft·lb and kgf·m
- Calibrated from 20% to 100% of tool range
- Torque, Torque & Angle and Torque Audit modes available
- Display and on-board storage of final torque or torque and angle values
- Memory capacity for 3,000 readings, time and date stamped
- USB and Bluetooth® 4.0 data transfer (also called Bluetooth® Smart)
- Complementary PC software ‘EvoLog’ for data management and tool configuration
- 12 user IDs can be downloaded to the tool and results can be stored against individual users
- Results can be output in CSV (comma-separated values) format for users not able to use EvoLog
- ‘Usage’ counter gives the ability to see the amount of times the tool has been used since the last reset
- ‘Turn Angle’ option can be used to check if bolts have already been tightened in an assembly process
- Supplied with a traceable calibration certificate for torque and angle as standard. Calibrated from 20% to 100% of tools maximum torque capacity, clockwise only



ET2-1000 & 1350



ET2-2700



ET2-4000



ET2-7000



EVOTORQUE®2



| 11 | EVOTORQUE 2 - 110 V |
|------------|---|
| 180230.B06 | ET2-72-1000-110, 3/4" sq. dr., 200 - 1,000 N·m |
| 180231.B06 | ET2-72-1350-110, 3/4" sq. dr., 270 - 1,350 N·m |
| 180232.B08 | ET2-72-2000-110, 1" sq. dr., 400 - 2,000 N·m |
| 180239.B08 | ET2-80-2700-110, 1" sq. dr., 540 - 2,700 N·m |
| 180238.B08 | ET2-92-4000-110, 1" sq. dr., 800 - 4,000 N·m |
| 180236.B12 | ET2-119-7000-110, 1 1/2" sq. dr., 1,400 - 7,000 N·m |

| 11 | EVOTORQUE 2 - 230 V |
|------------|---|
| 180220.B06 | ET2-72-1000-230, 3/4" sq. dr., 200 - 1,000 N·m |
| 180221.B06 | ET2-72-1350-230, 3/4" sq. dr., 270 - 1,350 N·m |
| 180222.B08 | ET2-72-2000-230, 1" sq. dr., 400 - 2,000 N·m |
| 180229.B08 | ET2-80-2700-230, 1" sq. dr., 540 - 2,700 N·m |
| 180228.B08 | ET2-92-4000-230, 1" sq. dr., 800 - 4,000 N·m |
| 180226.B12 | ET2-119-7000-230, 1 1/2" sq. dr., 1,400 - 7,000 N·m |



| Model | ET2-1000 ET2-1350 | ET2-2000 | ET2-2700 | ET2-4000 | ET2-7000 | |
|----------------------|--|--------------------------|--------------------------|--------------------------|--------------------------|-----|
| Part Number | 180230.B06 180220.B06 180231.B06 180221.B06 | 180232.B08 180222.B08 | 180239.B08 180229.B08 | 180238.B08 180228.B08 | 180236.B12 180226.B12 | |
| Output Speed (rpm) | 21 (ET-72-1000) 17 (ET-72-1350) | 11 | 10 | 6 | 3.3 | |
| Dimensions (mm) | ØD max. | 72 | 72 | 80 | 92 | 119 |
| | H1 | 45 | 45 | 45 | 45 | 45 |
| | H2 | 317 | 317 | 317 | 317 | 317 |
| | H3 | 109 | 109 | 109 | 109 | 109 |
| | L | 366 | 407 | 363 | 417 | 440 |
| | R1 | 71 | 76 | 76 | 70 | 90 |
| | R2 min. | 124 | 124 | 124 | 125 | 160 |
| | R2 max. | 167 | 167 | 167 | 175 | 210 |
| Tool Weight (kg) | 10.4 | 10.8 | 10.8 | 12.9 | 16.8 | |
| Reaction Weight (kg) | 1.5 | 1.5 | 1.5 | 2.6 | 3.9 | |

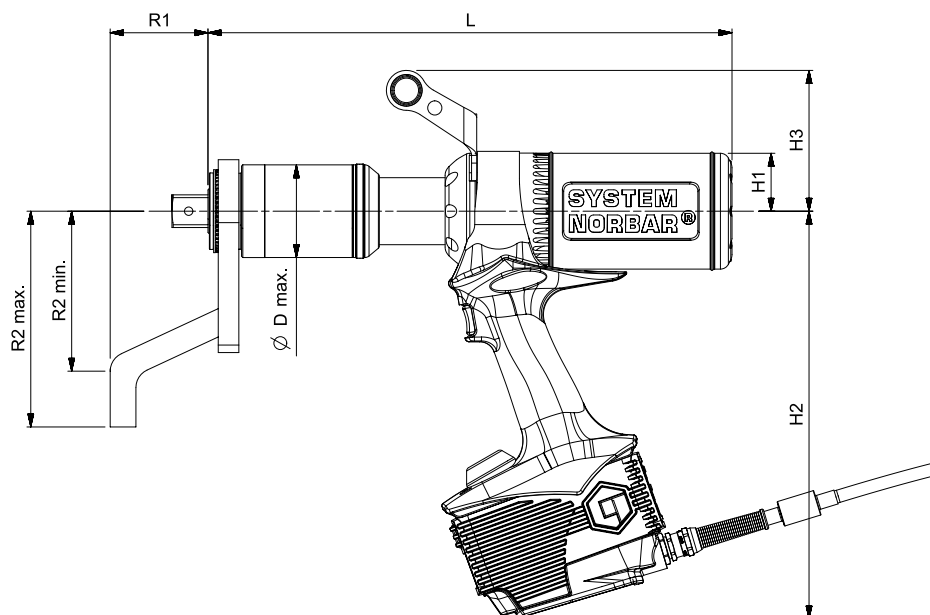

Patented in the UK and Germany (EP2699389) and in the USA (US9676086).



PNEUMATIC TORQUE TOOLS

What is a PneuTorque® Pneumatic Torque Tool?

The PneuTorque® consists of a robust air motor driving a Norbar multiplier with three or more stages of epicyclic gearing.

Torque control is achieved through adjustment of the air pressure. An air pressure versus torque graph and a calibration certificate is supplied with each tool and allows specific torque values to be set. For more critical applications, PneuTorques can be fitted with a torque transducer and the precise torque output displayed. The tool can then be shut off at the desired torque either manually or automatically using suitable control circuitry.

Why use PneuTorque® Pneumatic Torque Tools?

Hand operated torque multipliers are ideal for low volume or intermittent use or when there is no power source available. However, for production lines or whenever a large number of bolts is involved, a powered multiplier will save a considerable amount of time.

PneuTorque® operation is quiet – less than 84 dB(A) with absolutely no impacting. These two factors make PneuTorques comfortable for the operator to use, reducing fatigue and consequently increasing safety.

PneuTorques provide accurate torque control – on a given joint they will stall repeatedly to within ±5% (PTS tools, ±3%). Using electronic shut off, this repeatability can be improved to ±2%.

Summary of PneuTorque® Advantages:

- Sound pressure level does not exceed 84 dB(A) with an uncertainty K = 3dB
- No impacting means less damage to the tool, socket and bolted assembly
- Less operator fatigue, results in increased safety
- Powerful – models available up to 300,000 N·m (220,000 lbf·ft)
- Repeatability of ±5% for accurate torque control (±3% for PTS range)
- A wide range of attachments and accessories make PneuTorques adaptable to many applications

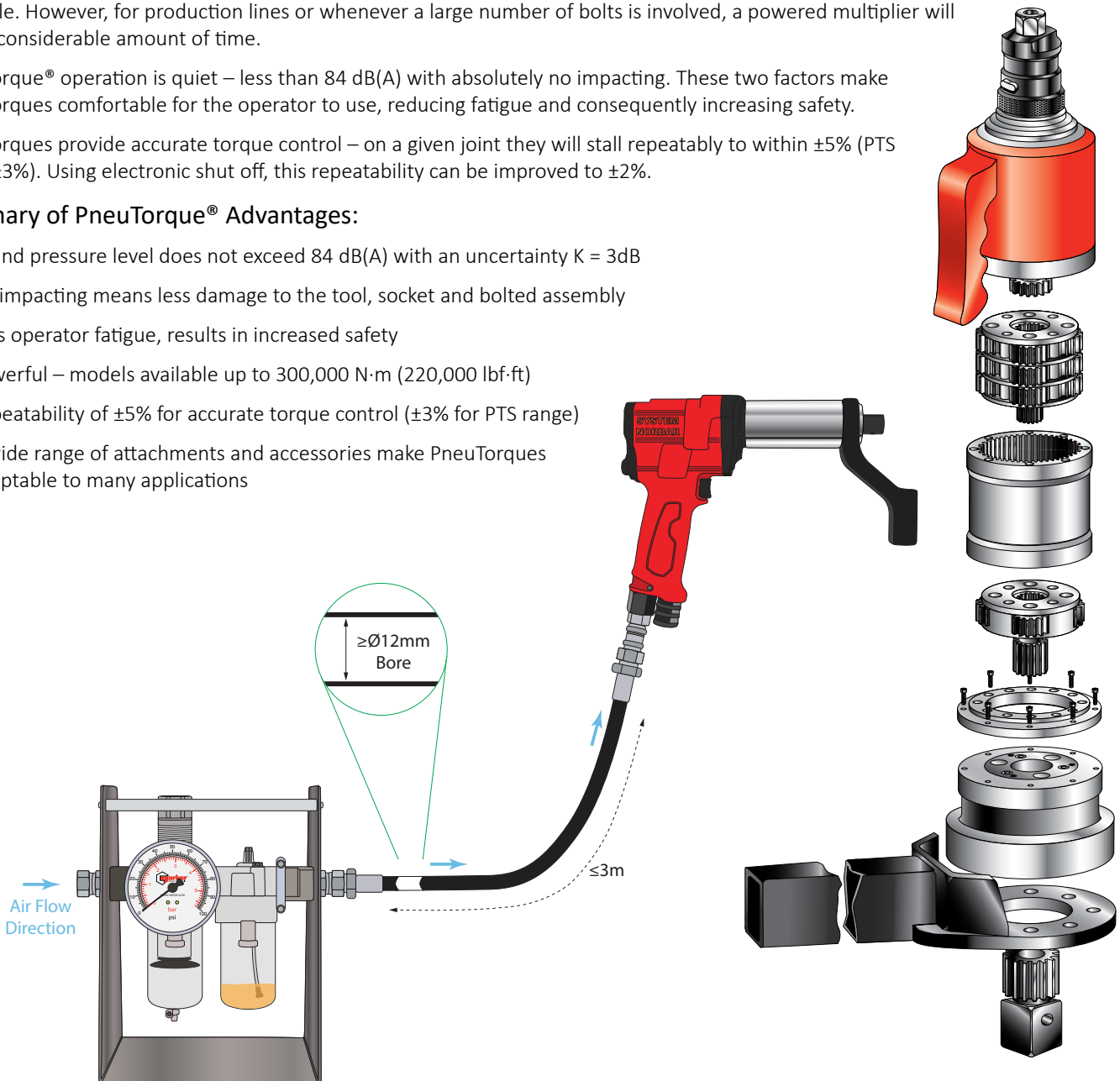
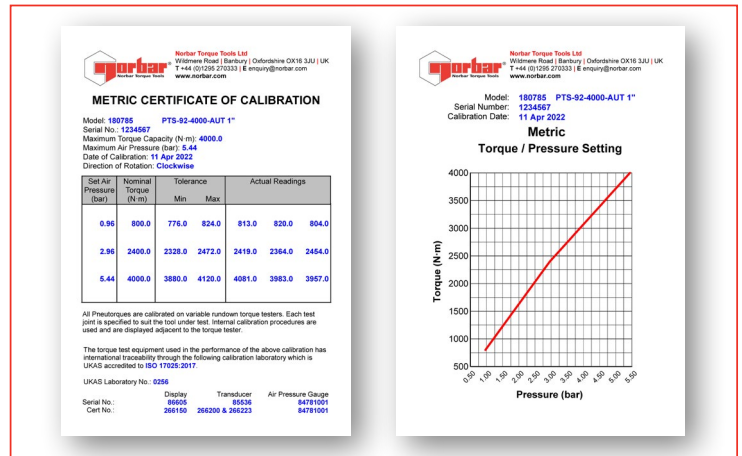



PNEUMATIC TORQUE TOOLS

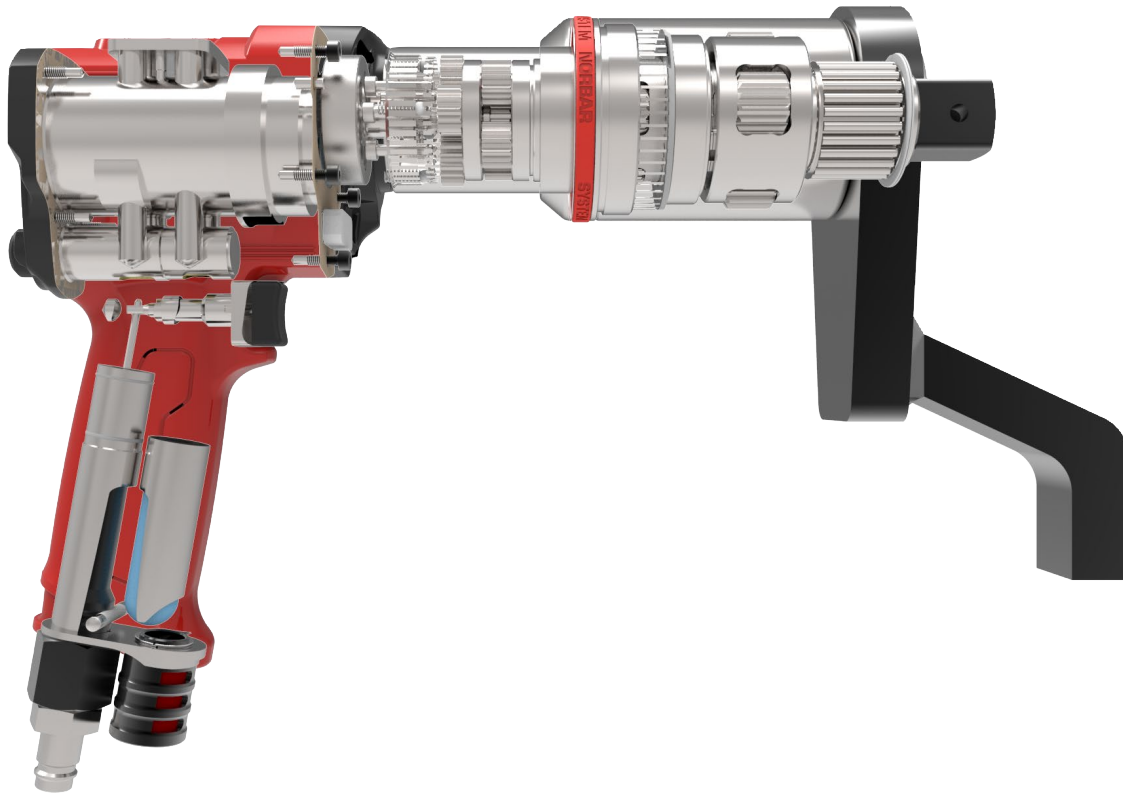

PneuTorque® Applications

The smooth and continuous torque output of the PneuTorque® makes these tools suitable for a wide range of bolting and non-bolting applications.

Bolting

PneuTorques are ideally suited to tightening and untightening bolts of up to 150 mm diameter. The following is just a small selection of applications:

- Wheel nuts on trucks, buses and large machinery
- Structural steelwork
- High pressure joints e.g. Pipelines, boiler feed pumps and pressure vessels
- Engine head bolts
- Injector heads on plastic injection moulding machines
- Heat exchangers
- Heavy vehicle production eg. chassis and suspension bolts



Non-bolting

Whenever a high continuous torque is needed, PneuTorques can be used as the power source. Typical applications include:

- Valve Actuation and valve grinding
- Powering wagons and gantries
- Barring of large diesel engines (turning the crankshaft) during build
- Weld testing by applying test torques
- Roller adjustment in steel mills and paper mills
- Valving of gas bottles





PNEUTORQUE® PTS™ SERIES



The PTS™ is the result of an extensive design project to produce an efficient air motor in an accurate torque tool. The air motor is then married to Norbar's respected gearbox range, sharing common torque reaction accessories with PTM, EvoTorque® 2 and EBT.

- Pistol grip handle for operator comfort
- Designed to offer excellent power-to-weight ratio
- Easily accessible switch for forward and reverse operation
- ±3% repeatability of reading from 20% to 100% of range
- Air coupling designed for safety and rapid operation
- Quiet operation - The sound pressure level is 77 dB(A) [the PTS™ 4000 is 79 dB(A)]. Uncertainty K = 3 dB
- Directional exhaust barrel directs exhaust away from operator
- Replaceable square drive
- Fast operation for rapid bolt rundown
- Non-impacting - exceptionally low vibration levels (0.343 m/s²), make these tools comfortable and safe for operator use
- Steel reactions supplied as standard. Bespoke reactions available upon request

When the tool is to be used for untightening bolts, Norbar recommends the selection of single speed versions. In the case of prevailing torque lock-nuts or partially tightening bolts, the Auto Two Speed version of the tools will generally give no advantage and single speed tools should be selected.

| 11 | PTS SERIES - STALL TOOLS - BI-DIRECTIONAL - SINGLE SPEED |
|------------|--|
| 180241.B06 | ¾" sq. dr., 100 - 500 N·m, 74 - 370 lbf-ft |
| 180242.B06 | ¾" sq. dr., 160 - 800 N·m, 118 - 590 lbf-ft |
| 180243.B06 | ¾" sq. dr., 200 - 1,000 N·m, 147 - 738 lbf-ft |
| 180244.B08 | 1" sq. dr., 270 - 1,350 N·m, 200 - 1,000 lbf-ft |
| 181454 | 1" sq. dr., 400 - 2,000 N·m, 295 - 1,475 lbf-ft |
| 180246.B08 | 1" sq. dr., 540 - 2,700 N·m, 398 - 1,991 lbf-ft |
| 180250.B08 | 1" sq. dr., 800 - 4,000 N·m, 590 - 2,950 lbf-ft |
| 180249.B12 | 1½" sq. dr., 1,400 - 7,000 N·m, 1,030 - 5,200 lbf-ft |

| 11 | PTS SERIES - STALL TOOLS - BI-DIRECTIONAL - AUTO TWO SPEED |
|--------|--|
| 180781 | ¾" sq. dr., 200 - 1,000 N·m, 147 - 738 lbf-ft |
| 180782 | 1" sq. dr., 270 - 1,350 N·m, 200 - 1,000 lbf-ft |
| 180784 | 1" sq. dr., 540 - 2,700 N·m, 398 - 1,991 lbf-ft |
| 180785 | 1" sq. dr., 800 - 4,000 N·m, 590 - 2,950 lbf-ft |
| 180788 | 1½" sq. dr., 1,400 - 7,000 N·m, 1,030 - 5,200 lbf-ft |





PNEUTORQUE® PTS™ SERIES



| Model | PTS-500 PTS-800 | PTS-1000 PTS-1350 | PTS-1000 Auto Two Speed PTS-1350 Auto Two Speed | PTS-2000 | PTS-2700 | PTS-2700 Auto Two Speed | PTS-4000 | PTS-4000 Auto Two Speed | PTS-7000 | PTS-7000 Auto Two Speed | |
|----------------------|--|--|--|------------|------------|-------------------------------|------------|-------------------------------|------------|----------------------------|------------|
| Part Number | 180241.B06 180242.B06 | 180243.B06 180244.B08 | 180781 180782 | 181454 | 180246.B08 | 180784 | 180250.B08 | 180785 | 180249.B12 | 180788 | |
| Output Speed (rpm) | 35.5 (PTS-52-500) 25.7 (PTS-52-800) | 20.4 (PTS-72-1000) 14.7 (PTS-72-1350) | 100 (PTS-72-1000) 75 (PTS-72-1350) | 9.2 | 7.3 | 30 | 5.3 | 22 | 2.6 | 13 | |
| Dimensions (mm) | ∅D max. | 52 | 72 | 72 | 68 | 80 | 80 | 92 | 92 | 119 | 119 |
| | H1 | 30 | 30 | 30 | 30 | 30 | 30 | 30 | 30 | 30 | 30 |
| | H2 | 243 | 243 | 243 | 243 | 243 | 243 | 243 | 243 | 243 | 243 |
| | L | 264 | 292 | 310 | 285 | 291 | 327 | 343 | 374 | 369 | 406 |
| | R1 | 59 | 74 | 74 | 74 | 74 | 74 | 74 | 75 | 90 | 90 |
| | R2 min. R2 max. | 71 131 | 124 165 | 124 167 | 120 165 | 124 165 | 124 167 | 125 175 | 125 175 | 160 210 | 160 210 |
| Tool Weight (kg) | 4.2 | 6.2 | 6.28 | 5.35 | 6.2 | 7.45 | 8.59 | 8.89 | 12.5 | 12.8 | |
| Reaction Weight (kg) | 0.9 | 1.4 | 1.4 | 1.1 | 1.4 | 1.4 | 2.5 | 2.5 | 3.9 | 3.9 | |

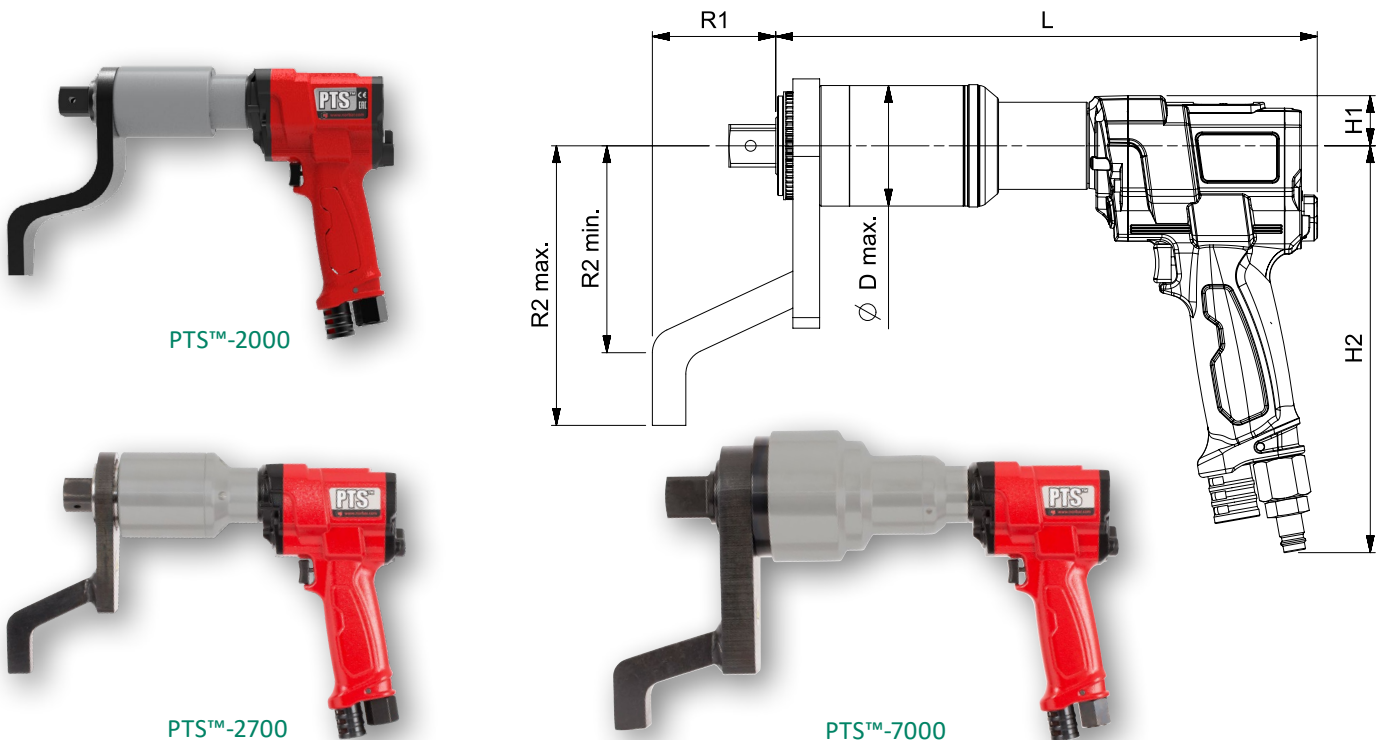



PNEUTORQUE® PTS™ REMOTE SERIES



Remote control versions have no direction control on the tool but rely on external pneumatic circuitry to provide this function. This opens up numerous application possibilities for the PneuTorque® ranging from simple stall shut-off in a hazardous working environment to sophisticated, multi-spindle torque and angle shut-off systems.

- Designed to offer excellent power-to-weight ratio
- ±3% repeatability of reading from 20% to 100% of range
- Replaceable square drive

NOTE: For full versatility, PTS™ Remotes are supplied without reaction see pages 70-71 for options or discuss bespoke engineered options with Norbar.

| 11 | PTS REMOTE SERIES |
|------------|--|
| 180271.B06 | ¾" sq. dr., 100 - 500 N·m, 74 - 370 lbf·ft |
| 180272.B06 | ¾" sq. dr., 160 - 800 N·m, 118 - 590 lbf·ft |
| 180273.B06 | ¾" sq. dr., 200 - 1,000 N·m, 147 - 738 lbf·ft |
| 180274.B08 | 1" sq. dr., 270 - 1,350 N·m, 200 - 1,000 lbf·ft |
| 181455 | 1" sq. dr., 400 - 2,000 N·m, 295 - 1,475 lbf·ft |
| 180276.B08 | 1" sq. dr., 540 - 2,700 N·m, 398 - 1,991 lbf·ft |
| 180295.B08 | 1" sq. dr., 800 - 4,000 N·m, 590 - 2,950 lbf·ft |
| 180279.B12 | 1½" sq. dr., 1,400 - 7,000 N·m, 1,030 - 5,200 lbf·ft |

| 11 | PTS REMOTE SERIES - AUTO TWO SPEED |
|--------|--|
| 180789 | ¾" sq. dr., 200 - 1,000 N·m, 147 - 738 lbf·ft |
| 180790 | 1" sq. dr., 270 - 1,350 N·m, 200 - 1,000 lbf·ft |
| 180792 | 1" sq. dr., 540 - 2,700 N·m, 398 - 1,991 lbf·ft |
| 180793 | 1" sq. dr., 800 - 4,000 N·m, 590 - 2,950 lbf·ft |
| 180796 | 1½" sq. dr., 1,400 - 7,000 N·m, 1,030 - 5,200 lbf·ft |

| Model | PTS REMOTE-500 | PTS REMOTE-800 | PTS REMOTE-1000 | PTS REMOTE-1350 | PTS REMOTE-2000 | PTS REMOTE-2700 | PTS REMOTE-4000 | PTS REMOTE-7000 |
|--------------------|----------------|----------------|-----------------|-----------------|-----------------|-----------------|-----------------|-----------------|
| Part Number | 180271.B06 | 180272.B06 | 180273.B06 | 180274.B08 | 181455 | 180276.B08 | 180295.B08 | 180279.B12 |
| Output Speed (rpm) | 27.8 | 20.1 | 16 | 11.5 | 7.2 | 5.7 | 4.1 | 2 |
| Dimensions (mm) | ∅D max. | 52 | 52 | 72 | 72 | 68 | 80 | 92 |
| | H1 | 29 | 29 | 29 | 29 | 29 | 29 | 29 |
| | H2 | 78 | 78 | 78 | 78 | 78 | 78 | 78 |
| | L | 284 | 284 | 311 | 311 | 302 | 311 | 362 |
| W | 70 | 70 | 70 | 70 | 70 | 70 | 70 | 70 |
| Tool Weight (kg) | 4.1 | 4.1 | 6.1 | 6.1 | 5.25 | 6.1 | 8.9 | 12.4 |

| Model | PTS REMOTE-1000 Auto Two Speed | PTS REMOTE-1350 Auto Two Speed | PTS REMOTE-2700 Auto Two Speed | PTS REMOTE-4000 Auto Two Speed | PTS REMOTE-7000 Auto Two Speed |
|--------------------|--------------------------------|--------------------------------|--------------------------------|--------------------------------|--------------------------------|
| Part Number | 180789 | 180790 | 180792 | 180793 | 180796 |
| Output Speed (rpm) | 78 | 56 | 22 | 20 | 10 |
| Dimensions (mm) | ∅D max. | 72 | 72 | 80 | 92 |
| | H1 | 29 | 29 | 29 | 29 |
| | H2 | 78 | 78 | 78 | 78 |
| | L | 330 | 330 | 344 | 395 |
| W | 70 | 70 | 70 | 70 | 70 |
| Tool Weight (kg) | 6.2 | 6.2 | 7.0 | 9.3 | 12.78 |

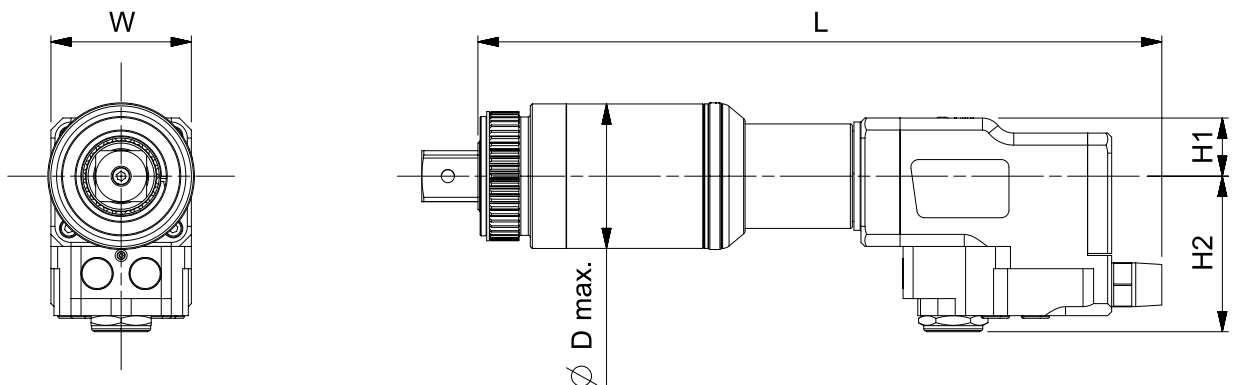



ET, ET2, PTS™ AND PTM NOSE EXTENSIONS

Special nose extension reaction devices are available for use in situations where the tool access is restricted. A typical application is the rear wheel nuts on heavy vehicles.



11 NOSE EXTENSIONS FOR 52 SERIES

| | |
|-----------|----------------------------|
| 18601.006 | 6" long, F/M 3/4" sq. dr. |
| 18601.009 | 9" long, F/M 3/4" sq. dr. |
| 18601.012 | 12" long, F/M 3/4" sq. dr. |

F/M = Female input square/Male output square

11 NOSE EXTENSIONS FOR 72 SERIES

| | |
|-----------|----------------------------|
| 19007.006 | 6" long, SPM/M 1" sq. dr. |
| 19007.009 | 9" long, SPM/M 1" sq. dr. |
| 19007.012 | 12" long, SPM/M 1" sq. dr. |

11 NOSE EXTENSIONS FOR 80 SERIES

| | |
|-----------|----------------------------|
| 19480.009 | 9" long, SPM/M 1" sq. dr. |
| 19480.012 | 12" long, SPM/M 1" sq. dr. |

SPM/M = Spline Male input/Male output square



11 SPLINED NOSE EXTENSIONS FOR 72/92 SERIES 1" DRIVE

| | |
|-----------|---|
| 19285.006 | ET2/EBT/PTS/PTM-72 6" long, 1" sq. dr. |
| 19285.009 | ET2/EBT/PTS/PTM-72 9" long, 1" sq. dr. |
| 19285.012 | ET2/EBT/PTS/PTM-72 12" long, 1" sq. dr. |
| 19047.006 | ET2/EBT/PTS/PTM-92 6" long, 1" sq. dr. |
| 19047.009 | ET2/EBT/PTS/PTM-92 9" long, 1" sq. dr. |
| 19047.012 | ET2/EBT/PTS/PTM-92 12" long, 1" sq. dr. |



11 SPLINED NOSE EXTENSIONS FOR 52 SERIES

| | |
|-----------|------------------------|
| 19045.006 | 6" long, 3/4" sq. dr. |
| 19045.009 | 9" long, 3/4" sq. dr. |
| 19045.012 | 12" long, 3/4" sq. dr. |

11 SPLINED NOSE EXTENSIONS FOR 72 SERIES 3/4" DRIVE

| | |
|-----------|------------------------|
| 19046.006 | 6" long, 3/4" sq. dr. |
| 19046.009 | 9" long, 3/4" sq. dr. |
| 19046.012 | 12" long, 3/4" sq. dr. |

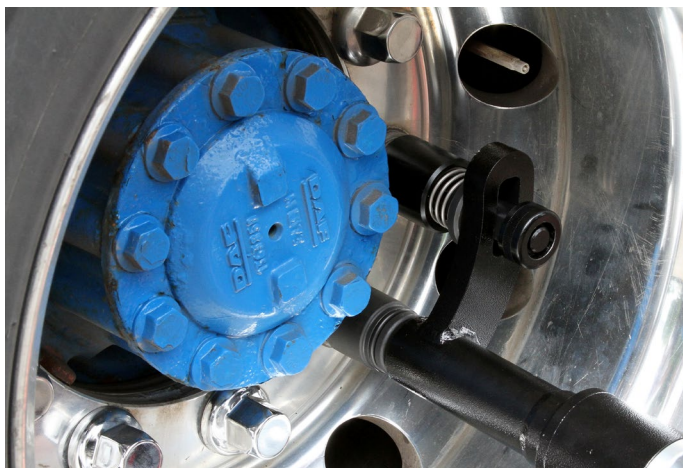

The TrukTorque™ nose extension features a special curved reaction arm designed to handle bolt tightening on the front and rear wheels of trucks and buses. The design easily accommodates wheel trims and deeply recessed wheel bolts.

11 NOSE EXTENSIONS FOR TRUCK AND BUS WHEELS (Fits PTM-72)

| | |
|-----------|-----------------------------------|
| 19087.009 | 1,000 N·m, 9" long, 3/4" sq. dr. |
| 19087.012 | 1,000 N·m, 12" long, 3/4" sq. dr. |
| 19089.009 | 1,000 N·m, 9" long, 1" sq. dr. |
| 19089.012 | 1,000 N·m, 12" long, 1" sq. dr. |



PNEUTORQUE® STANDARD SERIES



From left to right PT 5 Remote, PT 5 Single Speed, PT 5 Automatic Two Speed and PT 5 Manual Two Speed

Based on the original PneuTorque®, the ‘Standard Series’ range is a direct result of over 50 years of refinement and development necessary to keep pace with the requirements of industry today.

In use in many thousands of applications worldwide PneuTorque® wrenches continue to represent the foundation of Norbar’s powered tool range. Two speed models offer all the advantages of single speed versions but with the additional benefit of a run-down speed five times greater than the high torque speed setting.

- Models available for almost every bolting and torque application, up to 300,000 N·m.
Models above 6,000 N·m are Manufactured to Order, for more information please contact Norbar
- Forward and reverse operation
- Quiet : Noise level : 81dB(A), with an uncertainty K = 3dB, when free running
- Vibration : Does not exceed 2.5m/s² (highest measured under test: 0.444m/s²)
- Stall control gives repeatability of ±5% on a given joint
- Other reaction styles can be designed to suit specific applications
- Electronic torque transducers can be fitted for precise torque monitoring

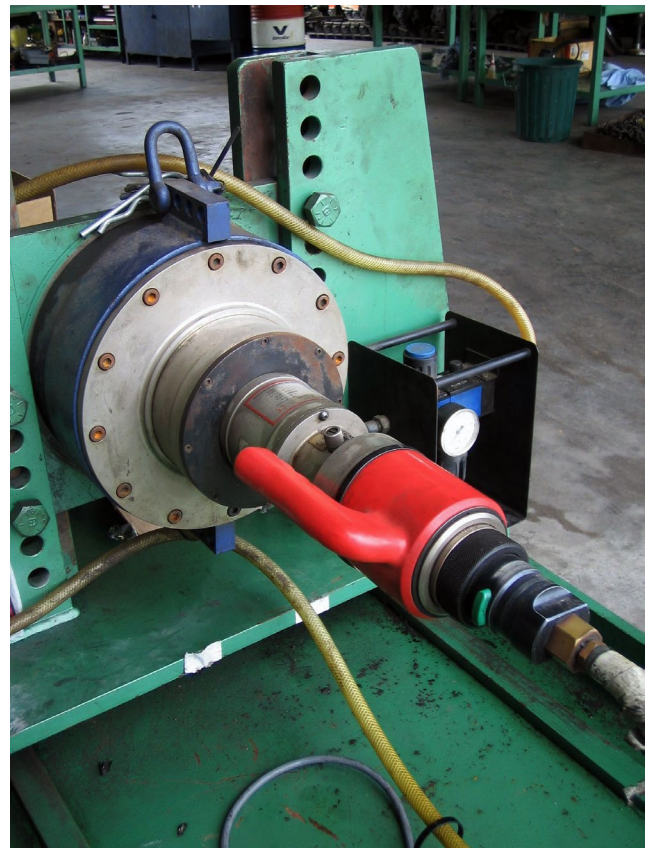



PNEUTORQUE® STANDARD SERIES



| 11 | TO 100,000 N·m - SINGLE SPEED |
|-------|---|
| 16031 | PT 1 ¾" sq. dr., 160 - 680 N·m, 120 - 500 lbf-ft |
| 16011 | PT 1 1" sq. dr., 160 - 680 N·m, 120 - 500 lbf-ft |
| 16098 | PT 1A ¾" sq. dr., 270 - 1,200 N·m, 200 - 900 lbf-ft |
| 16097 | PT 1A 1" sq. dr., 270 - 1,200 N·m, 200 - 900 lbf-ft |
| 16013 | PT 2 1" sq. dr., 515 - 1,700 N·m, 380 - 1,250 lbf-ft |
| 16015 | PT 5 1" sq. dr., 880 - 3,400 N·m, 650 - 2,500 lbf-ft |
| 16017 | PT 6 1½" sq. dr., 880 - 3,400 N·m, 650 - 2,500 lbf-ft |
| 16066 | PT 7 1½" sq. dr., 1,762 - 6,000 N·m, 1,300 - 4,500 lbf-ft |
| 16072 | PT 9 1½" sq. dr., 2,710 - 9,500 N·m, 2,000 - 7,000 lbf-ft |
| 16046 | PT 11 2½" sq. dr., 4,400 - 20,000 N·m, 3,250 - 14,700 lbf-ft |
| 18086 | PT 12 2½" sq. dr., 9,500 - 34,000 N·m, 7,000 - 25,000 lbf-ft |
| 16052 | PT 13 2½" sq. dr., 13,550 - 47,000 N·m, 10,000 - 35,000 lbf-ft |
| 16045 | PT 14 3½" sq. dr., 22,375 - 100,000 N·m, 16,500 - 73,500 lbf-ft |

| 11 | TO 9,500 N·m - AUTOMATIC TWO SPEED |
|-----------|---|
| 16031.AUT | PT 1 ¾" sq. dr., Auto 2SP 160 - 680 N·m, 120 - 500 lbf-ft |
| 16011.AUT | PT 1 1" sq. dr., Auto 2SP 160 - 680 N·m, 120 - 500 lbf-ft |
| 16098.AUT | PT 1A ¾" sq. dr., Auto 2SP 400 - 1,200 N·m, 295 - 900 lbf-ft |
| 16097.AUT | PT 1A 1" sq. dr., Auto 2SP 400 - 1,200 N·m, 295 - 900 lbf-ft |
| 16013.AUT | PT 2 1" sq. dr., Auto 2SP 700 - 1,700 N·m, 516 - 1,250 lbf-ft |
| 16015.AUT | PT 5 1" sq. dr., Auto 2SP 880 - 3,400 N·m, 650 - 2,500 lbf-ft |
| 16017.AUT | PT 6 1½" sq. dr., Auto 2SP 880 - 3,400 N·m, 650 - 2,500 lbf-ft |
| 16066.AUT | PT 7 1½" sq. dr., Auto 2SP 2,200 - 6,000 N·m, 1,622 - 4,500 lbf-ft |
| 16072.AUT | PT 9 1½" sq. dr., Auto 2SP 2,100 - 9,500 N·m, 2,286 - 7,000 lbf-ft |

MTS = Manual Two Speed. Auto 2SP = Automatic Two Speed.

Angle Encoders are available for Standard Series PTs please contact Norbar for further details.

NB: PneuTorque® PT 11 - PT 18 are supplied with a Lubro Control Unit as standard equipment. PneuTorques PT 12, 13 and 14 are also supplied with a weld prepared reaction ring as standard. PT 15 - 18 do not include output drive or reaction. These components will be engineered uniquely for each application. Remote PT part numbers are designated with an .X

e.g. PT 1 Remote is 16031.X

e.g. PT 1 Remote Auto is 16031.XAUT

For remote models, consult Norbar for prices.

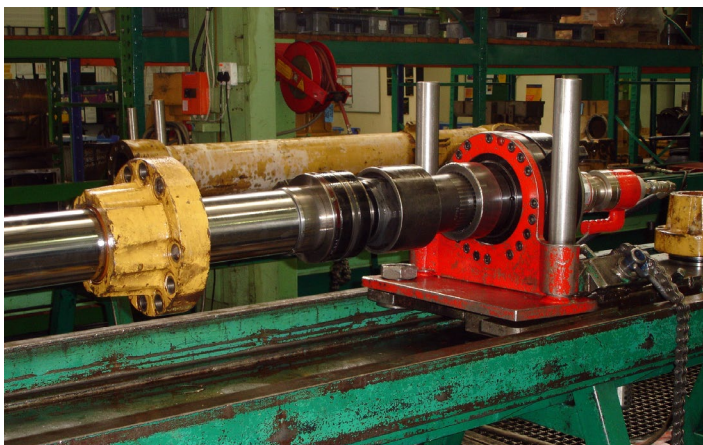

| 11 | TO 300,000 N·m - MANUAL TWO SPEED |
|-----------|--|
| 16031.MTS | PT 1 ¾" sq. dr., MTS 160 - 680 N·m, 120 - 500 lbf-ft |
| 16011.MTS | PT 1 1" sq. dr., MTS 160 - 680 N·m, 120 - 500 lbf-ft |
| 16098.MTS | PT 1A ¾" sq. dr., MTS 270 - 1,200 N·m, 200 - 900 lbf-ft |
| 16097.MTS | PT 1A 1" sq. dr., MTS 270 - 1,200 N·m, 200 - 900 lbf-ft |
| 16013.MTS | PT 2 1" sq. dr., MTS 515 - 1,700 N·m, 380 - 1,250 lbf-ft |
| 16015.MTS | PT 5 1" sq. dr., MTS 880 - 3,400 N·m, 650 - 2,500 lbf-ft |
| 16017.MTS | PT 6 1½" sq. dr., MTS 880 - 3,400 N·m, 650 - 2,500 lbf-ft |
| 16066.MTS | PT 7 1½" sq. dr., 1,762 - 6,000 N·m, 1,300 - 4,500 lbf-ft |
| 16072.MTS | PT 9 1½" sq. dr., 2,710 - 9,500 N·m, 2,000 - 7,000 lbf-ft |
| 16046.MTS | PT 11 2½" sq. dr., 4,400 - 20,000 N·m, 3,250 - 14,700 lbf-ft |
| 18086.MTS | PT 12 2½" sq. dr., 9,500 - 34,000 N·m, 7,000 - 25,000 lbf-ft |
| 16052.MTS | PT 13 2½" sq. dr., 13,550 - 47,000 N·m, 10,000 - 35,000 lbf-ft |
| 16045.MTS | PT 14 3½" sq. dr., 22,375 - 100,000 N·m, 16,500 - 73,500 lbf-ft |
| 18089.MTS | PT 15 MTS 40,000 - 150,000 N·m, 29,500 - 110,500 lbf-ft |
| 18090.MTS | PT 16 MTS 55,000 - 200,000 N·m, 40,500 - 147,500 lbf-ft |
| 18088.MTS | PT 17 MTS 70,000 - 250,000 N·m, 51,500 - 184,500 lbf-ft |
| 16054.MTS | PT 18 MTS 85,000 - 300,000 N·m, 62,500 - 221,500 lbf-ft |
| 16490 | Lifting Bracket for Standard Series (up to PT7) |

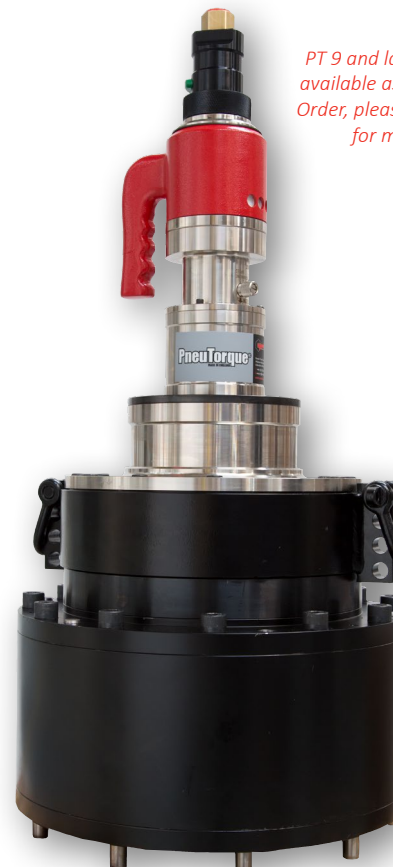

PT 9 and larger models are available as Manufacture to Order, please contact Norbar for more details



PNEUTORQUE® STANDARD SERIES



PneuTorque® Standard Series Manual Two Speed

| Model | PT 1 | PT 1A | PT 2 | PT 5 | PT 6 | PT 7 | PT 9 | PT 11 | PT 12 | PT 13 | PT 14 | PT 15 | PT 16 | PT 17 | PT 18 | |
|----------------------|------------------------|------------------------|-----------|-----------|-----------|-----------|-----------|-----------|-----------|-----------|-----------|-----------|-----------|-----------|-----------|-----|
| Part Number | 16031.MTS 16011.MTS | 16098.MTS 16097.MTS | 16013.MTS | 16015.MTS | 16017.MTS | 16066.MTS | 16072.MTS | 16046.MTS | 18086.MTS | 16052.MTS | 16045.MTS | 18089.MTS | 18090.MTS | 18088.MTS | 16054.MTS | |
| Output Speed (rpm) | 150 | 75 | 45 | 25 | 25 | 12.5 | 9 | 6 | 2.5 | 1.5 | 1 | 0.5 | 0.4 | 0.35 | 0.3 | |
| Dimensions (mm) | ∅D | 108 | 108 | 108 | 119 | 119 | 144 | 184 | 212 | 248 | 315 | 315 | * | 410 | 410 | 520 |
| | H | 436 | 436 | 436 | 479 | 481 | 509 | 504 | 581 | 622 | 664 | 729 | * | 866 | 939 | 936 |
| | L | 303 | 303 | 303 | 355 | 355 | 423 | 448 | 609 | 325 | 341 | 341 | * | N/A | N/A | N/A |
| | R1 | N/A | N/A | N/A | N/A | N/A | 84 | 84 | N/A | N/A | N/A | N/A | N/A | N/A | N/A | N/A |
| | R2 min. | 83 | 83 | 83 | 86 | 86 | 150 | 175 | 320 | N/A | N/A | N/A | N/A | N/A | N/A | N/A |
| | R2 max. | 216 | 216 | 216 | 263 | 263 | 331 | 351 | 500 | N/A | N/A | N/A | N/A | N/A | N/A | N/A |
| Tool Weight (kg) | 14.1 | 14.6 | 14.6 | 17.5 | 17.5 | 23.2 | 27.9 | 42.1 | 53.3 | 105.7 | 122.9 | * | 270.0 | 285.0 | 380.0 | |
| Reaction Weight (kg) | 2.2 | 2.2 | 2.2 | 2.5 | 2.5 | 6.3 | 8.3 | 13.3 | 6.5 | 6.9 | 10.4 | N/A | N/A | N/A | N/A | |

PneuTorque® Standard Series Single Speed

| Model | PT 1 | PT 1A | PT 2 | PT 5 | PT 6 | PT 7 | PT 9 | PT 11 | PT 12 | PT 13 | PT 14 | |
|----------------------|----------------|----------------|-------|-------|-------|-------|-------|-------|-------|-------|-------|-----|
| Part Number | 16031 16011 | 16098 16097 | 16013 | 16015 | 16017 | 16066 | 16072 | 16046 | 18086 | 16052 | 16045 | |
| Output Speed (rpm) | 30 | 15 | 9 | 5 | 5 | 2.5 | 1.8 | 1.2 | 0.5 | 0.3 | 0.2 | |
| Dimensions (mm) | ∅D | 108 | 108 | 108 | 119 | 119 | 144 | 184 | 212 | 248 | 315 | 315 |
| | H | 350 | 350 | 350 | 393 | 395 | 423 | 418 | 495 | 536 | 578 | 643 |
| | L | 303 | 303 | 303 | 355 | 355 | 423 | 448 | 609 | 325 | 341 | 341 |
| | R1 | N/A | N/A | N/A | N/A | N/A | 84 | 84 | N/A | N/A | N/A | N/A |
| | R2 min. | 83 | 83 | 83 | 86 | 86 | 150 | 175 | 320 | N/A | N/A | N/A |
| | R2 max. | 216 | 216 | 216 | 263 | 263 | 331 | 351 | 500 | N/A | N/A | N/A |
| Tool Weight (kg) | 10.6 | 11.1 | 11.1 | 14.0 | 14.0 | 19.7 | 24.4 | 38.6 | 49.8 | 102.2 | 119.4 | |
| Reaction Weight (kg) | 2.2 | 2.2 | 2.2 | 2.5 | 2.5 | 6.3 | 8.3 | 13.3 | 6.5 | 6.9 | 10.4 | |

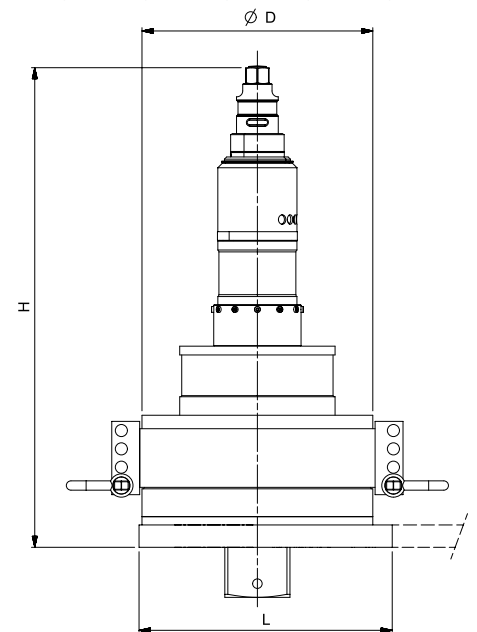

PneuTorque® Standard Series Automatic Two Speed

| Model | PT 1 | PT 1A | PT 2 | PT 5 | PT 6 | PT 7 | PT 9 | |
|----------------------|------------------------|------------------------|-----------|-----------|-----------|-----------|-----------|-----|
| Part Number | 16031.AUT 16011.AUT | 16098.AUT 16097.AUT | 16013.AUT | 16015.AUT | 16017.AUT | 16066.AUT | 16072.AUT | |
| Output Speed (rpm) | 150 | 75 | 45 | 25 | 25 | 12.5 | 9 | |
| Dimensions (mm) | ∅D | 108 | 108 | 108 | 119 | 119 | 144 | 184 |
| | H | 419 | 419 | 419 | 462 | 464 | 492 | 487 |
| | L | 303 | 303 | 303 | 355 | 355 | 423 | 448 |
| | R1 | N/A | N/A | N/A | N/A | N/A | 84 | 84 |
| | R2 min. | 83 | 83 | 83 | 86 | 86 | 150 | 175 |
| | R2 max. | 216 | 216 | 216 | 263 | 263 | 331 | 351 |
| Tool Weight (kg) | 14.1 | 14.6 | 14.6 | 17.5 | 17.5 | 23.2 | 27.9 | |
| Reaction Weight (kg) | 2.2 | 2.2 | 2.2 | 2.5 | 2.5 | 6.3 | 8.3 | |

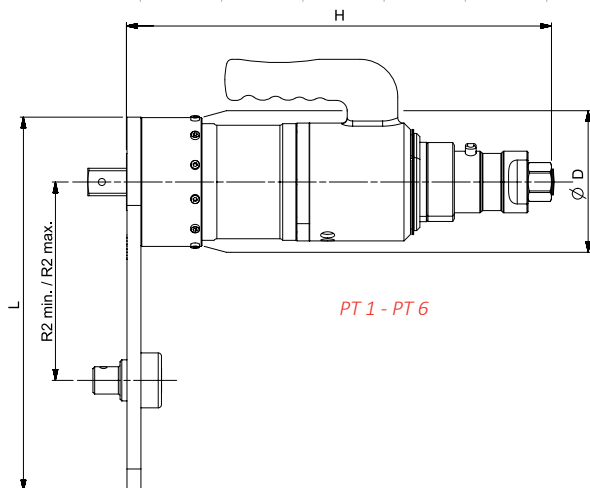

PT 1 - PT 6

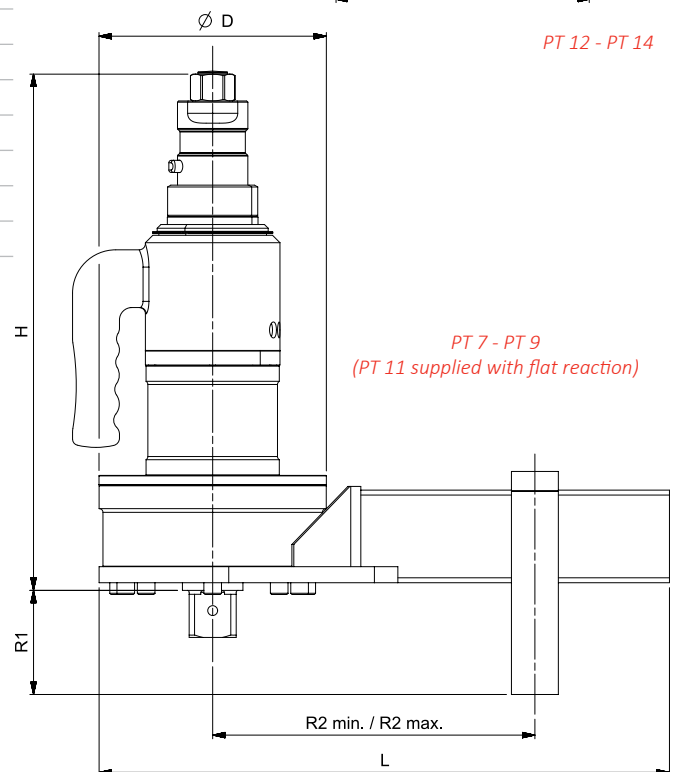

PT 12 - PT 14

PT 7 - PT 9
(PT 11 supplied with flat reaction)



PNEUTORQUE® STANDARD SERIES

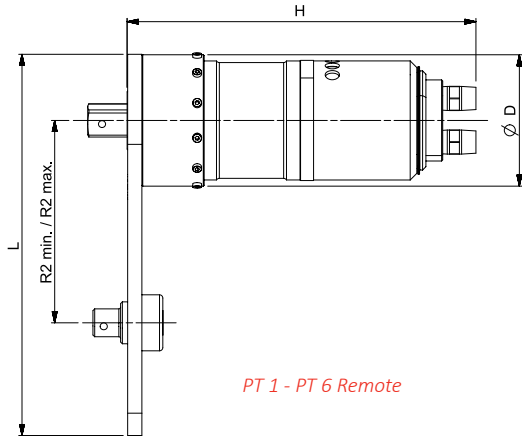

PneuTorque® Standard Series Automatic Two Speed - Remote

| Model | PT 1 | PT 1A | PT 2 | PT 5 | PT 6 | PT 7 | PT 9 |
|----------------------|--------------------------|--------------------------|------------|------------|------------|------------|------------|
| Part Number | 16031.XAUT 16011.XAUT | 16098.XAUT 16097.XAUT | 16013.XAUT | 16015.XAUT | 16017.XAUT | 16066.XAUT | 16072.XAUT |
| Output Speed (rpm) | 150 | 75 | 45 | 25 | 25 | 12.5 | 9 |
| Dimensions (mm) | ØD | 108 | 108 | 108 | 119 | 119 | 144 |
| | H | 339 | 339 | 339 | 382 | 383 | 412 |
| | L | 303 | 303 | 303 | 355 | 355 | 423 |
| | R1 | N/A | N/A | N/A | N/A | N/A | 84 |
| | R2 min. | 83 | 83 | 83 | 86 | 86 | 150 |
| | R2 max. | 216 | 216 | 216 | 263 | 263 | 331 |
| Tool Weight (kg) | 14.1 | 14.6 | 14.6 | 17.5 | 17.5 | 23.2 | 27.9 |
| Reaction Weight (kg) | 2.2 | 2.2 | 2.2 | 2.5 | 2.5 | 6.3 | 8.3 |

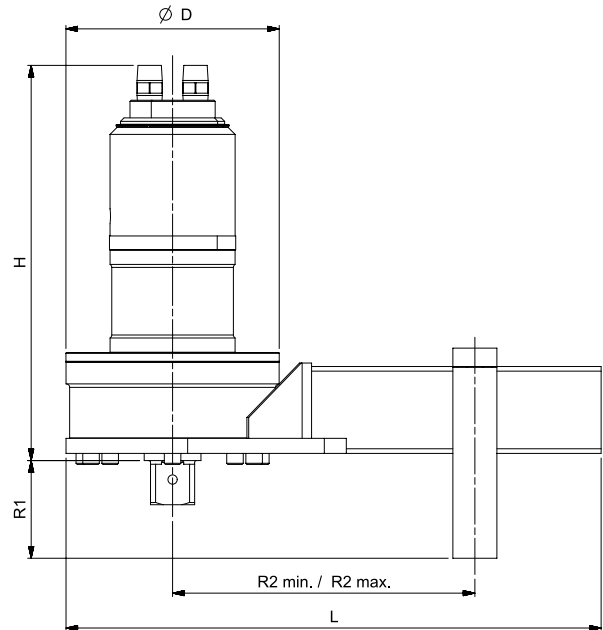

PneuTorque® Standard Series Single Speed - Remote

| Model | PT 1 | PT 1A | PT 2 | PT 5 | PT 7 | PT 9 | PT 11 | PT 12 | PT 13 | PT 14 |
|----------------------|--------------------|--------------------|---------|---------|---------|---------|---------|---------|---------|---------|
| Part Number | 16031.X 16011.X | 16098.X 16097.X | 16013.X | 16015.X | 16066.X | 16072.X | 16046.X | 18086.X | 16052.X | 16045.X |
| Output Speed (rpm) | 30 | 15 | 9 | 5 | 2.5 | 1.8 | 1.2 | 0.5 | 0.3 | 0.2 |
| Dimensions (mm) | ØD | 108 | 108 | 108 | 119 | 144 | 184 | 212 | 248 | 315 |
| | H | 270 | 270 | 270 | 313 | 343 | 340 | 415 | 456 | 490 |
| | L | 303 | 303 | 303 | 355 | 423 | 448 | 609 | 325 | 341 |
| | R1 | N/A | N/A | N/A | N/A | 84 | 84 | N/A | N/A | N/A |
| | R2 min. | 83 | 83 | 83 | 86 | 150 | 175 | 320 | N/A | N/A |
| | R2 max. | 216 | 216 | 216 | 263 | 331 | 351 | 500 | N/A | N/A |
| Tool Weight (kg) | 10.6 | 11.1 | 11.1 | 14.0 | 17.9 | 24.4 | 38.6 | 49.8 | 102.2 | 119.4 |
| Reaction Weight (kg) | 2.2 | 2.2 | 2.2 | 2.5 | 6.3 | 8.3 | 13.3 | 6.5 | 6.9 | 10.4 |

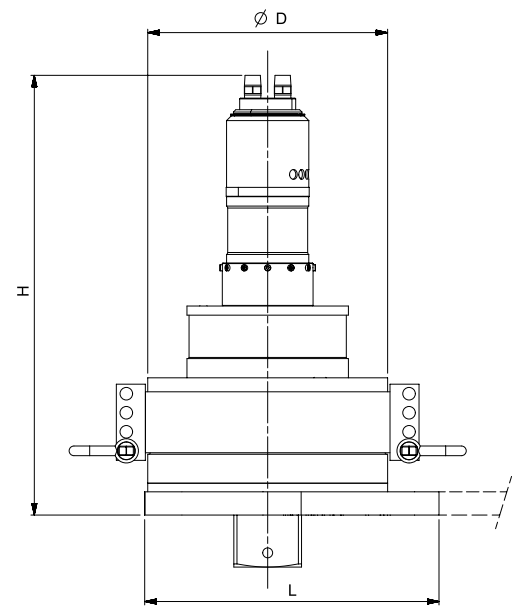

PneuTorque® Standard Series Manual Two Speed - Remote

| Model | PT 1 | PT 1A | PT 2 | PT 5 | PT 6 | PT 7 | PT 9 | PT 11 | PT 12 | PT 13 | PT 14 | PT 15 | PT 16 | PT 17 | PT 18 |
|----------------------|----------------------------|----------------------------|-------------|-------------|-------------|-------------|-------------|-------------|-------------|-------------|-------------|-------------|-------------|-------------|-------------|
| Part Number | 16031.XMSTS 16011.XMSTS | 16098.XMSTS 16097.XMSTS | 16013.XMSTS | 16015.XMSTS | 16017.XMSTS | 16066.XMSTS | 16072.XMSTS | 16046.XMSTS | 18086.XMSTS | 16052.XMSTS | 16045.XMSTS | 18089.XMSTS | 18090.XMSTS | 18088.XMSTS | 16054.XMSTS |
| Output Speed (rpm) | 150 | 75 | 45 | 25 | 25 | 12.5 | 9 | 6 | 2.5 | 1.5 | 1 | 0.5 | 0.4 | 0.35 | 0.3 |
| Dimensions (mm) | ØD | 108 | 108 | 108 | 119 | 119 | 144 | 184 | 212 | 248 | 315 | * | 410 | 410 | 520 |
| | H | 356 | 356 | 356 | 399 | 400 | 429 | 425 | 501 | 542 | 576 | * | 786 | 859 | 856 |
| | L | 303 | 303 | 303 | 355 | 355 | 423 | 448 | 609 | 325 | 341 | * | N/A | N/A | N/A |
| | R1 | N/A | N/A | N/A | N/A | N/A | 84 | 84 | N/A | N/A | N/A | N/A | N/A | N/A | N/A |
| | R2 min. | 83 | 83 | 83 | 86 | 86 | 150 | 175 | 320 | N/A | N/A | N/A | N/A | N/A | N/A |
| | R2 max. | 216 | 216 | 216 | 263 | 263 | 331 | 351 | 500 | N/A | N/A | N/A | N/A | N/A | N/A |
| Tool Weight (kg) | 14.1 | 14.6 | 14.6 | 17.5 | 17.5 | 23.2 | 27.9 | 42.1 | 53.3 | 105.7 | 122.9 | * | 270.0 | 285.0 | 380.0 |
| Reaction Weight (kg) | 2.2 | 2.2 | 2.2 | 2.5 | 2.5 | 6.3 | 8.3 | 13.3 | 6.5 | 6.9 | 10.4 | N/A | N/A | N/A | N/A |

* Available on request



TORQUE REACTION

This page applies to both HandTorque® multipliers and powered torque tools

Principles of Torque Reaction

Newton’s law dictates that for every applied force there is an equal and opposite reactive force. For applications requiring relatively low torques that can be applied with a torque wrench, this does not present a problem as the reactive force is absorbed by the operator. However, if the desired torque necessitates the use of a multiplier, the resultant reactive force can only be absorbed using an appropriate reaction device.

For this reason all Norbar multipliers are supplied with a reaction plate or reaction foot fitted as standard.

All of the standard reaction plates and feet supplied with standard Norbar tools have been designed to enable the multiplier’s use in a variety of environments. However, due to an infinite number of bolting arrangements, it is impossible to have one reaction device that will satisfy every customer’s requirement. See page 70-71 for when the supplied standard reaction is not suitable.

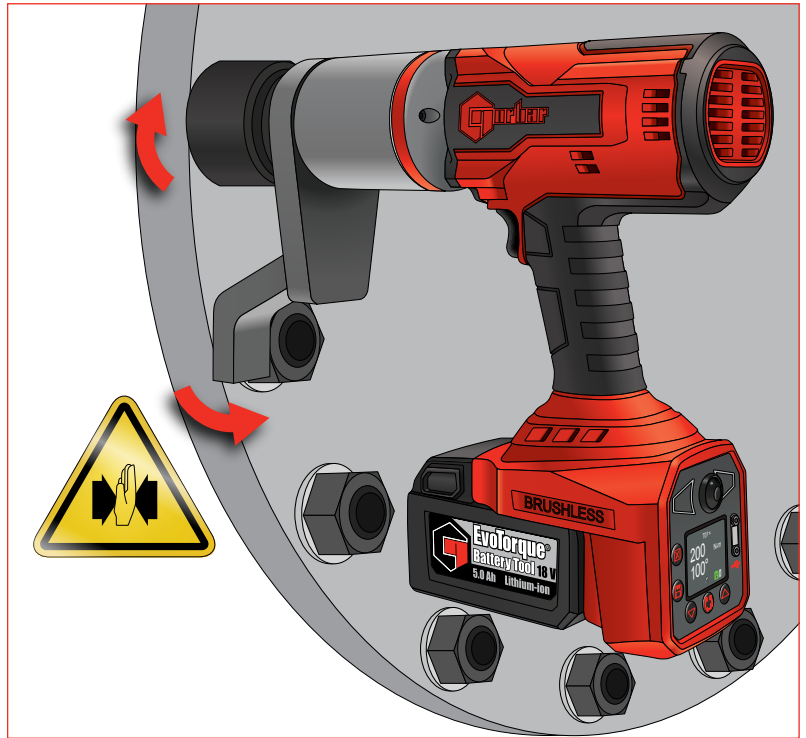

In the above example, 1,000 N·m torque output will result in a reactive force of 6,667 N at a point 0.15 m from the axis of rotation or 2,000 N at 0.5 m.

Avoiding Torque Reaction Problems

It has already been mentioned that the reaction force is equal to the force being applied. However, the magnitude of the reaction force is dependent upon the perpendicular distance between the point of reaction and the centre line of the multiplier, ie. the greater the distance the lower the force.

For this reason the point of reaction should be kept as far away from the centre line of the gearbox as is practical.

Customers using or modifying reaction plates for Standard Series multipliers up to a capacity of 3,400 N·m should note that if the reaction is taken on the radiused part, the reaction force is perpendicular to the tangent of the curve. Consequently, the further around the radius the reaction is taken, the smaller the perpendicular distance and therefore the greater the force.

Although a longer reaction plate may mean lower forces, the bending moment close to the multiplier will increase.

Customers extending the length of Norbar’s standard reaction plates should be aware that an increase in overall length will result in a larger induced bending stress and should not assume that because the reaction plate is strong enough at one length it will remain so when extended.

Excessive side loading, resulting from poor reaction, increases frictional forces inside the multiplier. This can lead to lower multiplication ratios (outside ±4%).

The ideal reaction arrangement has the centre of the reaction bar and the centre of the nut on a perpendicular line to the centre line of the tool.

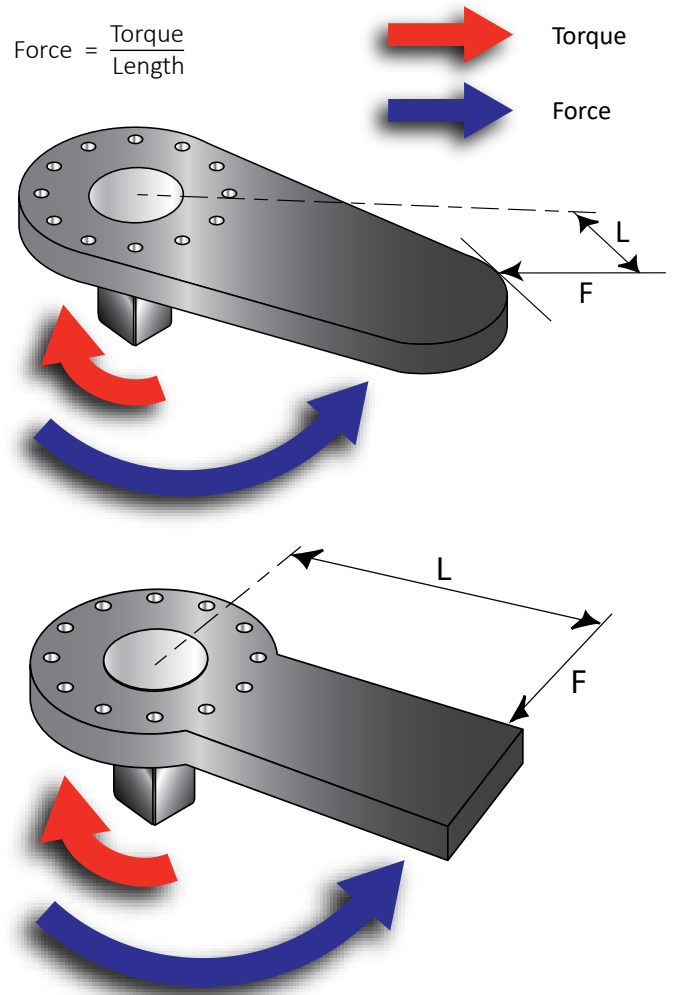



TORQUE REACTION

This page applies to both HandTorque® multipliers and powered torque tools



Points to remember

- Take the reaction as far away from the multiplier as practical
- Ensure that the reaction point remains square to the multiplier wherever possible as this will minimise any additional stress in the output square, which could result in premature failure. If the multiplier tilts under load, the reaction may not be square
- For applications that do not allow the reaction to be taken securely it is advisable to use a double-sided or balanced reaction plate

Reaction Force

When using multipliers and PneuTorques the reaction point must be capable of withstanding the reaction force. Therefore, great care must be exercised where the reaction is taken when applying high torques to studs and bolts.

By using the following formula you can calculate the force at the point of reaction. The greater the distance the lower the force.

D = Stud Diameter

$$\text{Formula to calculate Area of Stud} = \frac{\pi \times D^2}{4}$$

$$\text{Formula to calculate shear force: Shear Force} = \frac{\text{Reaction Force}}{\text{Area of Stud}}$$

What to do if the standard reaction device is not suitable

For those applications that do not permit the use of a standard reaction plate the customer has three options.

- Norbar or an authorised Norbar distributor will design and manufacture a special purpose reaction plate to the customer's requirements
- The customer can modify the standard reaction plate to suit their requirements
- The customer can fabricate their own reaction device after liaison with Norbar's technical department or a Norbar distributor

Customers wishing to either modify the original reaction plate or fabricate their own device should read the above information on how to avoid common torque reaction problems.



TORQUE REACTION

A variety of reaction plates, manufactured in Steel or Aluminium for HandTorque®, EvoTorque®, EvoTorque® Battery Tool and PneuTorque®. Norbar also offer a range of specific reactions for the Wind Energy Generation Industry.

| | |
|-------|-----------------------------------|
| 11 | REACTION FOR HT/PTS/PTM-52 SERIES |
| 18646 | Steel Cranked Reaction for 52 mm |

| | |
|-------|---------------------------------------|
| 11 | REACTION FOR ET/EBT/PTS/PTM-68 SERIES |
| 19611 | Steel Cranked Reaction for 68 mm |



Steel Cranked Reaction for 68 mm Gearbox

11 SPLINED REACTION FOR HT/ET/EBT/PTS/PTM-72 & 80 SERIES

| | | | | | |
|-------|--|--|-------|--|--|
| 19289 | Steel Cranked Reaction for 72 mm and 80 mm | | 18494 | Aluminium Cranked Reaction for 72 mm and 80 mm | |
|-------|--|--|-------|--|--|

11 SPLINED REACTION FOR HT/ET/EBT/PTS/PTM-92 SERIES

| | | | | | |
|-------|----------------------------------|--|-------|--------------------------------------|--|
| 19291 | Steel Cranked Reaction for 92 mm | | 18936 | Aluminium Cranked Reaction for 92 mm | |
|-------|----------------------------------|--|-------|--------------------------------------|--|

11 SPLINED REACTION FOR HT/ET/EBT/PTS/PTM-119 SERIES

| | | | | | |
|-------|--|--|-------|--|--|
| 19293 | Steel Cranked Reaction for 119 mm (Max. 7,000 N·m) | | 18961 | Aluminium Cranked Reaction for 119 mm (Max. 6,000 N·m) | |
|-------|--|--|-------|--|--|

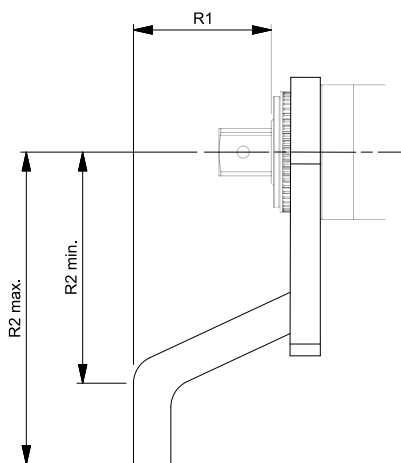

11 SPECIAL SPLINED REACTION FOR HT/ET/EBT/PTS/PTM-92 SERIES

| | |
|-------|----------------------------------|
| 78028 | Steel Cranked Reaction for 92 mm |
|-------|----------------------------------|

11 SPECIAL SPLINED REACTION FOR HT/ET/EBT/PTS/PTM-119 SERIES

| | |
|-------|-----------------------------------|
| 78027 | Steel Cranked Reaction for 119 mm |
|-------|-----------------------------------|

11 SPECIAL SPLINED REACTION FOR API FLANGES

| | |
|-------|--|
| 78029 | HT/ET/EBT/PTS/PTM-72 & 80 Series Steel Crowfoot Reaction for 1¼" – 1½"(M30 – M39) nuts/bolts |
| 78028 | HT/ET/EBT/PTS/PTM-92 Series Steel Cranked Reaction (see image above) for 1½" – 1¾"(M42 – M48) nuts/bolts |
| 78030 | HT/ET/EBT/PTS/PTM-119 Series Steel Crowfoot Reaction for 2" – 2½"(M52 – M64) nuts/bolts |

| Part Number | R1 | R2 min | R2 max |
|-------------|--------|--------|--------|
| 18646 | 59 mm | 71 mm | 131 mm |
| 19611 | 75 mm | 120 mm | 165 mm |
| 19289 | 76 mm | 124 mm | 167 mm |
| 18494 | 68 mm | 91 mm | 165 mm |
| 19291 | 70 mm | 125 mm | 175 mm |
| 18936 | 87 mm | 115 mm | 205 mm |
| 19293 | 90 mm | 160 mm | 210 mm |
| 18961 | 118 mm | 150 mm | 199 mm |

| Part Number | R1 | R2 min | R2 max |
|-------------|--------|--------|--------|
| 78027 | 90 mm | 148 mm | 248 mm |
| 78028 | 70 mm | 57 mm | 145 mm |
| 78029 | 76 mm | 45 mm | 115 mm |
| 78030 | 110 mm | 70 mm | 156 mm |



TORQUE REACTION

A variety of steel reaction plates and adaptors, together with ancillary feet, blades and heads to aid their use are available for HandTorque®, EvoTorque®, EvoTorque® Battery Tool and PneuTorque®.

| 11 SPECIAL SPLINED REACTION FOR RAIL | |
|--------------------------------------|---|
| Q4714 | HT/ET/EBT/PTS/PTM-52 Series Pegged Reaction Plate Max Torque 500 N·m |
| Q5000 | HT/ET/EBT/PTS/PTM-72 Series Pegged Reaction Plate Max Torque 1,500 N·m |



Q4714 Pegged Reaction Plate for rail

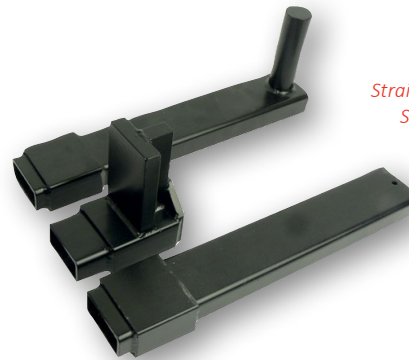

Straight Reaction with Peg (18298)
Short Reaction Foot (18241)
Straight Reaction (18291)

| 11 FOR HT/EBT/PTS/PTM-52 SERIES | |
|---------------------------------|-------------------------------|
| 18590 | Double-Sided Reaction Plate |
| 18576 | Straight Reaction Plate |
| 62236 | Reaction Plate Spline Adaptor |

| 11 FOR ET/EBT/PTS/PTM-68 SERIES | |
|---------------------------------|-----------------------------|
| 19783 | Double-Sided Reaction Plate |

| 11 FOR HT/ET/EBT/PTS/PTM-72 & 80 SERIES | |
|---|-----------------------------|
| 18293 | Double-Sided Reaction Plate |
| 18292 | Straight Reaction Plate |

| 11 FOR ET/EBT/PTS/PTM-92 SERIES | |
|---------------------------------|--------------------------------------|
| 18979 | Straight Reaction Plate |
| 18980 | Double-Sided Straight Reaction Plate |

| 11 FOR ET/EBT/PTM-119 SERIES | |
|------------------------------|--------------------------------------|
| 16687 | Straight Reaction Plate |
| 18981 | Double-Sided Straight Reaction Plate |

Double-Sided Reaction Plate (18293)

Straight Reaction Plate (18292)

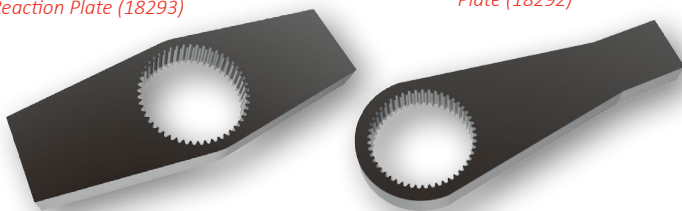

| 11 ANCILLARY ITEMS FOR USE WITH 18290 OR 18558 | |
|--|--|
| 18558 | Reaction Adaptor for HT/ET/EBT/PTS/PTM-52 Series |
| 18290 | Reaction Adaptor for HT/ET/EBT/PTS/PTM-72 Series |
| 18298 | Straight Reaction with Peg |
| 18291 | Straight Reaction |
| 18241 | Short Reaction Foot |
| 18358 | Sliding Reaction Blade (to be used with 18291) |
| 18359 | Sliding Reaction Spigot Head (to be used with 18291) |

Sliding Reaction (180300.092.B08)



| 11 SLIDING REACTIONS | |
|----------------------|---|
| 180300.052.B06 | 52 mm diameter Sliding Reaction ¾" sq. |
| 19785.068.B06 | 68 mm diameter Sliding Reaction ¾" sq. |
| 19785.068.B08 | 68 mm diameter Sliding Reaction 1" sq. |
| 180300.072.B06 | 72 mm diameter Sliding Reaction ¾" sq. |
| 180300.072.B08 | 72 mm diameter Sliding Reaction 1" sq. |
| 180300.080.B08 | 80 mm diameter Sliding Reaction 1" sq. |
| 180300.092.B08 | 92 mm diameter Sliding Reaction 1" sq. |
| 180300.092.B12 | 92 mm diameter Sliding Reaction 1 ½" sq. |
| 180300.119.B12 | 119 mm diameter Sliding Reaction 1 ½" sq. |

| 11 LIGHT-WEIGHT REACTIONS | |
|---------------------------|--|
| 19214 | ET/EBT/PT/PTS/PTM-72 API Class 4 Light-Weight Reaction |



Light-Weight Reaction (19214)

Reaction Weld Ring



Sliding Spigot Reaction Plate (18436)

| 11 REACTION WELD RINGS | |
|------------------------|--------------------------------|
| 18694 | For HT/EBT/PTS/PTM-52 |
| 19784 | For ET/EBT/PTS/PTM-68 |
| 18695 | For HT/ET/EBT/PTS/PTM-72 & 80 |
| 18696 | For HT/ET/EBT/PTS/PTM-92 |
| 18697 | For HT/ET/EBT/PTS/PTM-119 |
| 19871 | EBT-C 750 Reaction Weld Ring |
| 19784 | EBT-C 1,100 Reaction Weld Ring |

| 11 FOR HT 60 / PT 4500 / PT 5500 | |
|----------------------------------|--------------------------------------|
| 16687 | Single-Sided Straight Reaction Plate |
| 18436 | Sliding Spigot Reaction Plate |

| 11 FOR ET/EBT/PTS/PTM-68 SERIES | |
|---------------------------------|--------------------------------------|
| 19782 | Single-Sided Straight Reaction Plate |

| 11 FOR HT 30 / PT 2700 | |
|------------------------|--------------------------------------|
| 16686 | Single-Sided Straight Reaction Plate |



PTS™ AND PTM DUAL TRIGGER MODULE (DTM)



Dual Trigger Module (19286)

A secondary trigger for use with all PTS and PTM tools that easily attaches between the tool's air inlet port and hose. This requires the operator to use both hands to run the tool and so reduces the risk of hands getting trapped between the reaction bar and reaction point.

- Inlet ½" BSPP Female
- Outlet ½" BSPP Male



| | |
|-------|---|
| 11 | DUAL TRIGGER MODULE |
| 19286 | Dual Trigger Module for use with any PneuTorque |

To order a pre-assembled tool add the suffix .DTM onto the end of the part number.

NOTE: When fitting a DTM the torque tool must be recalibrated with the DTM in place, contact Norbar for details.

SECONDARY HANDLE



The secondary handle is an easy to fit and versatile accessory which offers additional support and ease of handling when applying torque with Norbar's powered tools. The secondary handle is designed to fit directly to all new powered tools which have a handle location groove in the annulus which is covered by a red rubber band (see inset image to the right).

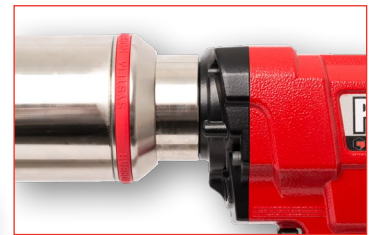

| | |
|--|--|
| 11 | SECONDARY HANDLE |
| 19363 | For use with ET2/EBT/PTS/PTM 72, 92 & 119 Series |
| 19448 | For use with ET2/EBT/PTS/PTM 80 Series |
| Not suitable for use with ET2/EBT/PTS/PTM 52 and 68 Series | |

RIGHT ANGLE GEARBOX MODULE

Right Angle Gearbox (180280)



The Right Angle Gearbox Adaptor will provide most ET, EBT, PTS™ and PTM tools with a 90° angle of operation, enabling the benefits of Norbar's pneumatic and electric torque tools to be brought to a host of applications from which they are currently excluded due to space restrictions.

- The tool handle can rotate 360° in relation to the Right Angle Gearbox allowing the most comfortable and safest position to be found
- The Right Angle Gearbox can be purchased as a stand-alone product and retrofitted to existing Norbar tools by suitably qualified technicians. Norbar recommend tool recalibration after a Right Angle Gearbox has been fitted but where this is not possible, an efficiency of 97% can be assumed.

| | |
|--------|--|
| 11 | RIGHT ANGLE GEARBOX MODULE |
| 180280 | For use with ET2/EBT/PTS/PTM 72, 80, 92 & 119 Series |
| 181486 | For use with ET2/EBT/PTS/PTM 68 Series |



RIGHT ANGLE GEARBOX MODULE

| | |
|---------------|---|
| 11 | EVOTORQUE 2 - 110 V - RIGHT ANGLE GEARBOX |
| 180230.B06.RA | ET2-72-1000-110, 3/4" sq. dr., 200 - 1,000 N·m |
| 180231.B06.RA | ET2-72-1350-110, 3/4" sq. dr., 270 - 1,350 N·m |
| 180232.B08.RA | ET2-72-2000-110, 1" sq. dr., 400 - 2,000 N·m |
| 180239.B08.RA | ET2-80-2700-110, 1" sq. dr., 540 - 2,700 N·m |
| 180238.B08.RA | ET2-92-4000-110, 1" sq. dr., 800 - 4,000 N·m |
| 180236.B12.RA | ET2-119-7000-110, 1 1/2" sq. dr., 1,400 - 7,000 N·m |

| | |
|---------------|---|
| 11 | EVOTORQUE 2 - 230 V - RIGHT ANGLE GEARBOX |
| 180220.B06.RA | ET2-72-1000-230, 3/4" sq. dr., 200 - 1,000 N·m |
| 180221.B06.RA | ET2-72-1350-230, 3/4" sq. dr., 270 - 1,350 N·m |
| 180222.B08.RA | ET2-72-2000-230, 1" sq. dr., 400 - 2,000 N·m |
| 180229.B08.RA | ET2-80-2700-230, 1" sq. dr., 540 - 2,700 N·m |
| 180228.B08.RA | ET2-92-4000-230, 1" sq. dr., 800 - 4,000 N·m |
| 180226.B12.RA | ET2-119-7000-230, 1 1/2" sq. dr., 1,400 - 7,000 N·m |



Right Angle Gearbox fitted to EvoTorque®2



Right Angle Gearbox fitted to PTS™

| | |
|-----------|--|
| 11 | PTS SERIES - STALL TOOLS - BI-DIRECTIONAL - AUTO TWO SPEED - RIGHT ANGLE GEARBOX |
| 180781.RA | 3/4" sq. dr., 200 - 1,000 N·m, 147 - 738 lbf·ft |
| 180782.RA | 1" sq. dr., 270 - 1,350 N·m, 200 - 1,000 lbf·ft |
| 180784.RA | 1" sq. dr., 540 - 2,700 N·m, 398 - 1,991 lbf·ft |
| 180785.RA | 1" sq. dr., 800 - 4,000 N·m, 590 - 2,950 lbf·ft |
| 180788.RA | 1 1/2" sq. dr., 1,400 - 7,000 N·m, 1,030 - 5,200 lbf·ft |

| | |
|---------------|--|
| 11 | PTS SERIES - STALL TOOLS - BI-DIRECTIONAL - SINGLE SPEED - RIGHT ANGLE GEARBOX |
| 180241.B06.RA | 3/4" sq. dr., 100 - 500 N·m, 74 - 370 lbf·ft |
| 180242.B06.RA | 3/4" sq. dr., 160 - 800 N·m, 118 - 590 lbf·ft |
| 180243.B06.RA | 3/4" sq. dr., 200 - 1,000 N·m, 147 - 738 lbf·ft |
| 180244.B08.RA | 1" sq. dr., 270 - 1,350 N·m, 200 - 1,000 lbf·ft |
| 181454.B08.RA | 1" sq. dr., 400 - 2,000 N·m, 295 - 1,475 lbf·ft |
| 180246.B08.RA | 1" sq. dr., 540 - 2,700 N·m, 398 - 1,991 lbf·ft |
| 180250.B08.RA | 1" sq. dr., 800 - 4,000 N·m, 590 - 2,950 lbf·ft |
| 180249.B12.RA | 1 1/2" sq. dr., 1,400 - 7,000 N·m, 1,030 - 5,200 lbf·ft |

| | |
|---------|---|
| 13 | EBT SERIES - SINGLE SPEED - 'SAFE TO START' - RIGHT ANGLE GEARBOX |
| 180353 | 3/4" sq. dr., 160 - 800 N·m, 118 - 600 lbf·ft, Kit |
| 180449* | 1" sq. dr., 200 - 1,350 N·m, 150 - 1,000 lbf·ft, Kit |
| 180497 | 1" sq. dr., 400 - 2,000 N·m, 295 - 1,475 lbf·ft, Kit |
| 180545 | 1" sq. dr., 400 - 2,700 N·m, 295 - 2,000 lbf·ft, Kit |
| 180641 | 1" sq. dr., 800 - 4,000 N·m, 590 - 2,950 lbf·ft, Kit |

| | |
|---------|---|
| 13 | EBT SERIES - AUTO TWO SPEED - 'SAFE TO START' - RIGHT ANGLE GEARBOX |
| 180473* | 1" sq. dr., 338 - 1,350 N·m, 250 - 1,000 lbf·ft, Kit |
| 180569 | 1" sq. dr., 676 - 2,700 N·m, 499 - 2,000 lbf·ft, Kit |
| 180665 | 1" sq. dr., 1,000 - 4,000 N·m, 738 - 2,950 lbf·ft, Kit |

*1,350 N·m models come supplied with both 3/4" and 1" sq. dr.



Right Angle Gearbox fitted to EBT



LUBRO CONTROL UNITS



Lubro Control Unit, part number 16074

Norbar's standard filter, regulator, lubricator unit 16074 features a 100 mm diameter gauge for easy and accurate setting of air pressure with ergonomic placement of air pressure adjustment control. Supplied with 3 metres of robust, steel braided air hose with fittings to connect to PneuTorque® wrenches.

Twin Regulator Lubro Control Unit, part number 16075

The 'Twin Lubro' has the same features as Norbar's standard filter, regulator, lubricator unit but has the benefit of two regulators and a switch that allows quick selection between two air pressure settings. A typical application for this would be a PneuTorque® user wishing to quickly select between two applications requiring different torque settings. For example, this might be controlled torque in the forward direction and maximum torque allowed by the tool in the reverse direction.



16074



16075

| 11 | LUBRO CONTROL UNITS |
|-------|--|
| 16074 | Lubro Control Unit with 3 m hose |
| 60339 | MPa only gauged Lubro Control Unit with 3 m hose |
| 16075 | Twin Lubro Control Unit with 3 m hose |

See page page 134 for Lubro Control Unit spares.

SOCKET RETAINERS



These socket retaining clips make attaching sockets to square drives easy and quick.

| 8 | SOCKET RETAINING CLIPS |
|-------|---|
| 19556 | Socket Retaining Clip for 3/4" sq. dr. (Yellow) - Pack of 10 |
| 19557 | Socket Retaining Clip for 1" sq. dr. (Red) - Pack of 10 |
| 19558 | Socket Retaining Clip for 1 1/2" sq. dr. (Green) - Pack of 10 |
| 19559 | Socket Retaining Clip for 2 1/2" sq. dr. (Blue) - Pack of 10 |



This product is intended for general purpose use at ground level. It is not intended as a solution for socket retention when working at height or where FOD (foreign object damage) could cause a safety and/or commercial risk.

Not recommended for use with impact tools.



CONNECTED TOOLS



- EBT for use with G400 and G400MP 76
- Torque Controller System Global 400 Series 77
- Multi-Port Torque Controller System Global 400MP Series 77

These systems are designed to error proof processes where highly customised products are assembled. When combined with the EBT customers can ensure correct torque has been achieved at key critical bolting steps of their processes monitored by the Global 400 or Global 400MP.





EBT FOR USE WITH G400 AND G400MP



Norbar’s highly accurate transducer controlled EBT battery powered torque tool perfectly complements and connects with Sturtevant Richmond’s Global 400 series Torque Controller systems via Xbee radio. These systems are designed to error-proof processes where highly customised products are assembled. When combined with the EBT customers can ensure correct torque has been achieved at key critical bolting steps of their processes monitored by the Global 400 or Global 400MP.

EBT is a transducer controlled battery powered torque tool designed for accurately applying torque to threaded fasteners. The unique ‘intelligent joint sensing’ technology continually measures the joint during tightening and when necessary, employs dynamic braking to avoid torque over-shoot due to motor inertia. Both accuracy and repeatability of ±3% of the setting within the calibrated range.

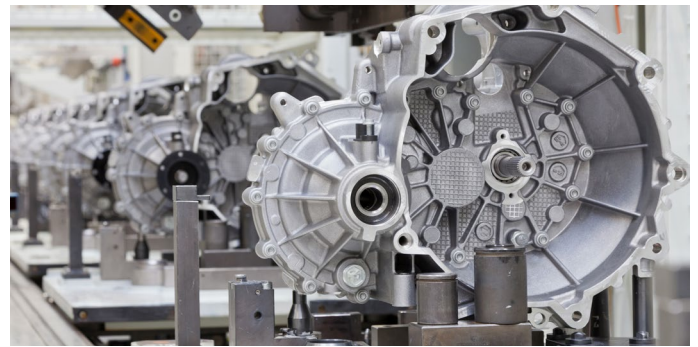

- Powerful motor coupled with either a single speed or auto two speed gearbox for rapid joint completion times
- Tool is not constrained by power cable or hose, improving safety, convenience and versatility
- OLED display ensures visibility in all conditions
- Clear indication of successful joint application
- 12 user IDs can be downloaded to the tool and results can be stored against individual users
- 20 unique stand-alone targets plus 20 unique work group targets for each work group
- 'Safe to start' button ensures hands are safely positioned at start up
- Quiet with noise levels that do not exceed 79.1dB(A)
- Non-impacting with vibration that do not exceed 2.5m/s²

13 EBT SERIES G400 CONTROLLER COMPATIBLE TOOLS

| | |
|--------|----------------------|
| 180357 | EBT 800 G400 |
| 180453 | EBT 1350 G400 |
| 180477 | EBT 1350-AUT G400 |
| 180549 | EBT 2700 G400 |
| 180573 | EBT 2700-AUT G400 |
| 180645 | EBT 4000 G400 |
| 180669 | EBT 4000-AUT G400 |
| 180858 | EBT 800 G400 ST |
| 180906 | EBT 1350 G400 ST |
| 180930 | EBT 1350-AUT G400 ST |
| 180954 | EBT 2700 G400 ST |
| 180978 | EBT 2700-AUT G400 |
| 181002 | EBT 4000 G400 |
| 181026 | EBT 4000-AUT G400 ST |

13 EBT-CA SERIES G400 CONTROLLER COMPATIBLE TOOLS

| | |
|--------|------------------|
| 181476 | EBT-CA 750 G400 |
| 181480 | EBT-CA 1100 G400 |

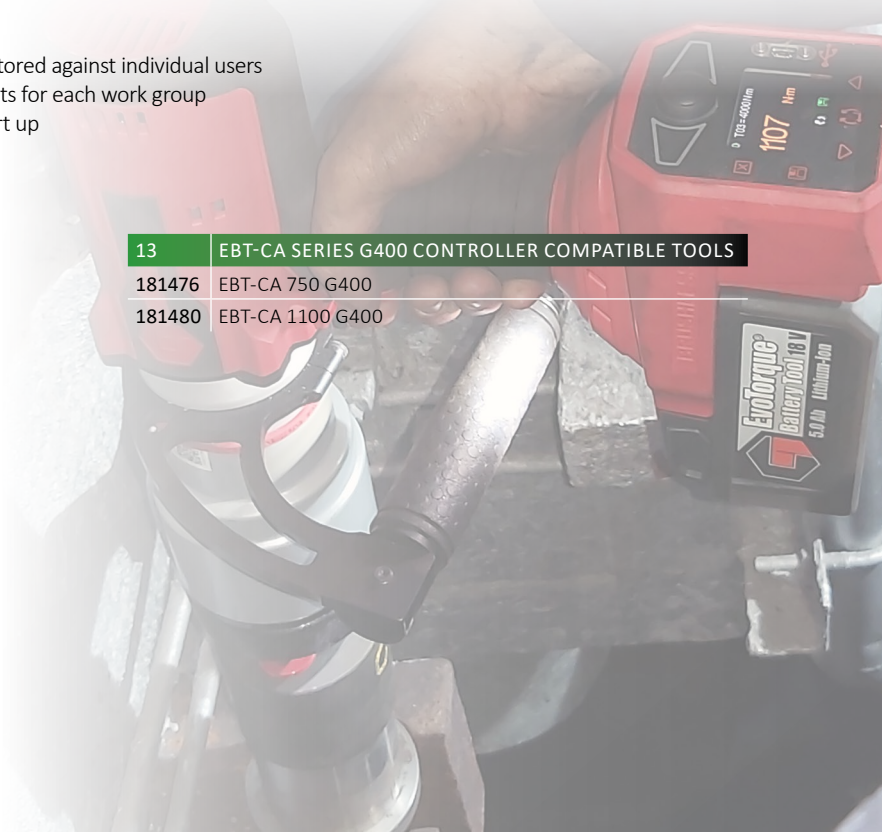

For more information contact Norbar.



TORQUE CONTROLLER SYSTEM GLOBAL 400 SERIES

**Utilise connected wireless tooling to error-proof your processes**

The Global 400 is designed to organise workstations where highly customised products are assembled. It can work with 16 primary torque tools, 8 holding tools and an additional 8 I/O tools. It has the capacity for 100 sets of parameters that can be grouped allowing 4 operators to work as a team. These parameters or groups can be formed into jobs containing a fixed build sequence of up to 35 steps. Error-proofs your processes using connected wireless tooling.

- Supports up to 16 Sturtevant Richmond tools as well as the Norbar EvoTorque® Battery Tool
- Works with many protocols and MES systems (EitherNet IP, Open Protocol, Toolsnet, 24 Volt I/O)
- Supports the use of barcode scanners to further error proof your process
- Has the capability for 100 sets of parameters
- 10 pin I/O connector providing discreet I/O capabilities

System Capabilities:

- 6 inch diagonal, back-lit colour LCD display
- USB-A connector for use with barcode scanner, or updating firmware and saving files
- RS-232 D-Sub9 Connector for use with serial barcode scanner or serial printer
- Key switch for programming access, 21 function keys for programming
- Adjustable and programmable beeper for audio communication



MULTI-PORT TORQUE CONTROLLER SYSTEM GLOBAL 400MP SERIES

**Designed to organise multiple workstations where highly customised products are assembled**

The Global 400mp distributes all the power, flexibility, ease and capabilities of the Global 400 over 4 individual network interfaces. The result? Up to 4 operators can work independently and don't even have to be in the same work cell.

4 separate network interfaces and Global 400mp architecture eliminate the need for groups in order to support simultaneous work.

Parameters are formed directly into jobs. With 4 network interfaces each operator can work on their own job, independent of the other operators.

The Global 400mp can be applied to assembly, repair and maintenance operations.

- Has the ability to work with 4 different stations/operators simultaneously through multiple ports
- Supports up to 16 Sturtevant Richmond tools as well as the Norbar EvoTorque® Battery Tool
- Works with many protocols and MES systems (EitherNet IP, Open Protocol, Toolsnet, 24 Volt I/O)
- Supports the use of barcode scanners to further error proof your process
- Has the capability for 100 sets of parameters
- 10 pin I/O connector providing discreet I/O capabilities







TORQUE MEASUREMENT



- Torque Measurement 80
- TruCheck™ 2 81
- TruCheck™ 2 (0.1 - 30 N·m) 82
- TruCheck™ 2 (3 - 2,100 N·m) 83
- T-Box™ 2 84
- Torque Screwdriver Tester (TST) 86
- Torque Tool Tester (TTT) 87
- Professional Torque Tester (Pro-Test) 88
- Spares for Instrumentation Products 89
- Static Transducer Bench Stands 89
- Part Number Suffix System 89
- Static Transducers 90
- Rotary Transducers 92
- Transducer Leads 93
- Annular Transducers 93
- Flange Mounted Transducers (FMT) 96
- ISO 3000 Loader 97
- Torque Wrench Calibrator - Manual 98
- Torque Wrench Calibrator - Ancillaries 99
- Torque Wrench Calibrator - Auto 100
- Test Rigs and Fixtures 102

Norbar started manufacturing electronic torque measuring instruments in the early 1970s and now offers a comprehensive range from the easy to use, cost-effective TruCheck™ 2 through to the sophisticated T-Box™ 2. Norbar's torque measuring instruments are renowned for high accuracy and superb reliability.



Measurement and Calibration - Glossary of Terms

The following information may help in selecting the appropriate measuring device for your needs.

Accuracy

The precision of the instrument which can be reported in three ways:

1. By quoting the guaranteed tolerance as a percentage of the reading or indicated value (eg. '0.5% of reading').
2. By quoting the guaranteed tolerance as a percentage of the full scale value of the instrument (eg. 0.1% FS or 0.1% FSD).
3. By quoting a 'class' of device in accordance with BS7882:2017 'Method for calibration and classification of torque measuring devices'.

Modes of Operation

First Peak of Torque - when a 'click type' torque wrench signals that the set torque has been achieved, the applied torque will momentarily drop before climbing again. Generally the fastener stops rotating at point 1 and from a standstill, the breakaway torque to achieve further rotation of the fastener will be higher than point 3b. Only if the operator is very insensitive to the break point will the final tightening effort be incorrect.

'First Peak of Torque' mode will detect the break point of the torque wrench, not the highest torque applied.

Peak Torque - this mode of operation will record the highest torque applied. In the case of a 'click type' torque wrench this may be higher than the actual break point if the wrench continues to be loaded beyond the break.

Consequently, Peak Torque is more useful for calibrating devices without a break signal such as dial or electronic wrenches.

Track - this mode has no memory at all. When the load is removed the display will return to zero.

Track is used for calibrating the device itself or for monitoring a fluctuating torque.

Resolution

The smallest measurement interval that can be determined on the indicating device. This applies to analogue and digital devices.

Number of Digits

Digital displays are described as having a certain number of 'digits' or 'active digits'. Half digits can be used to increase the resolution of a device without the expense of going to an additional full active digit.

Example 1. 1,000 N·m displayed on a 4 digit system would read 1000 (resolution = 1 N·m).

Example 2. 1,000 N·m displayed on a 4½ digit system would read 1000.0 (resolution = 0.1 N·m).

Active digits change as the torque changes. Non-active digits only assist in showing the magnitude of the torque. For example, 10,000 N·m requires 5 digits to display its magnitude.

Example 3. With 4 active digits (and 1 passive digit), 10,000 N·m would change in steps of 10 N·m.

Example 4. With 4½ or 5 active digits, 10,000 N·m would change in steps of 1 N·m.

Signal Processing

Electronic circuitry falls broadly into two types, analogue and digital, with most electronic measurement systems comprising a mixture of the two. There are also whole analogue electronic systems, but these are rare in torque measurement. Most systems start with an analogue signal. The point at which the signal is converted defines the type.

Analogue systems – one in which the signal is processed before being converted to digital.

Digital systems – the original analogue signal is converted to digital before processing.

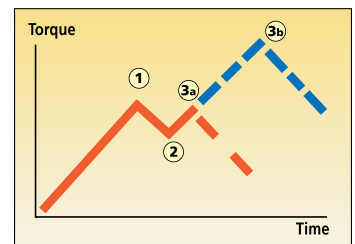

- 1 = Torque wrench activates
- 2 = 'Click' heard
- 3a = Wrench released quickly
- 3b = Wrench released slowly



TRUCHECK™ 2



This cost-effective torque wrench checker has been redesigned to incorporate improved features whilst maintaining ease of use. The TruCheck™ 2 aims to cut the cost of purchasing a torque wrench checking system and remove the fears over the complexity of using such equipment.

- Enables torque wrench performance to be monitored as part of your strategy to keep wrenches in peak condition
- LCD display with clear target indication from colour changing display (Plus version only). Visible in poorly lit work areas
- Two versions, TruCheck™ 2 and TruCheck™ 2 Plus available
- 'Basic' version has limited settable options. Ideal for non-expert users with click type torque wrenches
- TruCheck™ 2 Plus allows a selection of torque units, three modes of operation (Click, Dial and Track), the ability to store up to 15 targets and select from 12 languages
- Plus version allows operator to set a target value and tolerance
- ±1% of reading accuracy (±2% when below 10% of range for the 10 N·m and 1,100 N·m TruCheck™ 2 model)
- Inbuilt Micro USB 2.0 port enables power from any USB power source. Plus version allows for both power and data transfer simultaneously
- Supplied with traceable calibration certificate in clockwise direction. A counter-clockwise calibration is available at additional cost
- Software can be updated remotely, without the need to return the product to Norbar

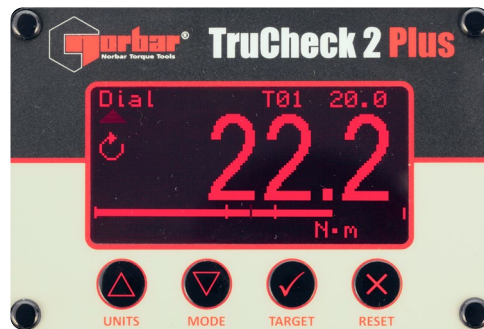

TruCheck™ 2 Plus display showing above target tolerance

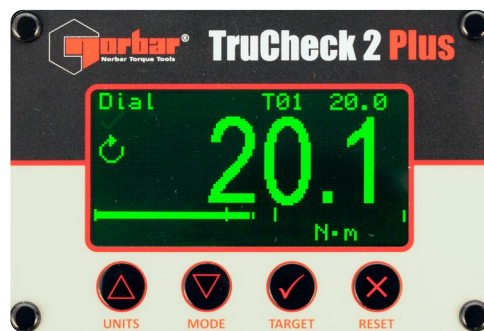

TruCheck™ 2 Plus display showing within target tolerance

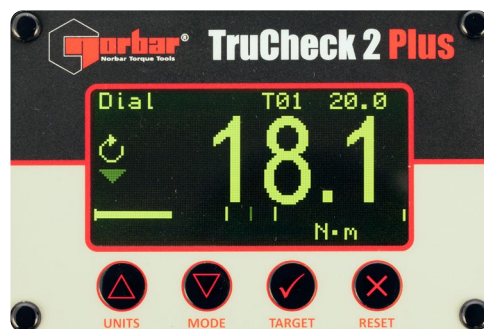

TruCheck™ 2 Plus display showing below target tolerance





TRUCHECK™ 2 (0.1 - 30 N·m)



TruCheck™ 2 Plus 3 N·m



TruCheck™ 2 with Torque Screwdriver (not included)

| 4 | TRUCHECK 2 (0.1 - 30 N·m) |
|--------|-------------------------------|
| 43514* | TruCheck 2, 0.1 - 3 N·m |
| 43515* | TruCheck 2 Plus, 0.1 - 3 N·m |
| 43516* | TruCheck 2, 0.5 - 10 N·m |
| 43517* | TruCheck 2 Plus, 0.5 - 10 N·m |
| 43518* | TruCheck 2, 1.5 - 30 N·m |
| 43563* | TruCheck 2 Plus, 1.5 - 30 N·m |

* 43514, 43515, 43516 and 43517 supplied with ¼" male hexagon and ¼" female sq. dr. adapter

* 43518 and 43563 supplied with 10 mm male hexagon, ¼" and ⅜" female sq. dr. adapter

| 12 | |
|----------|---|
| TCACC.CW | UKAS accredited calibration all sizes - clockwise |
| TCACC. | UKAS accredited calibration all sizes - clockwise and counter-clockwise |
| CW+CCW | counter-clockwise |

NOTE: If you order a UKAS accredited calibration, this certificate will be provided in place of the traceable calibration certificate and over the operating range as indicated on the device.

NOTE: For applicable Joint Simulators please refer to the FMT (Ancillary Section) on page page 96

| Model | TruCheck 2/Plus 0.1 - 3.0 N·m 0.5 - 10 N·m | TruCheck 2/Plus 1.5 - 30 N·m | |
|---|--|---------------------------------|-----|
| Part Number | 43514, 43515, 43516, 43517 | 43518, 43563 | |
| Range | 0.1 - 3.0 N·m 0.5 - 10 N·m | 1.5 - 30 N·m | |
| In-Built Transducer Male Hex Drive Size | ¼" | 10 mm | |
| Dimensions (mm) | A | 175 | 175 |
| | B | 10 | 10 |
| | ØC | 6.5 | 6.5 |
| | D | 55 | 55 |
| | E | 10 | 10 |
| | F | 64 | 64 |
| | G | N/A | 72 |
| | H | 64 | 64 |
| J | 72 | N/A | |
| Weight (kg) | 1.4 | 1.4 | |

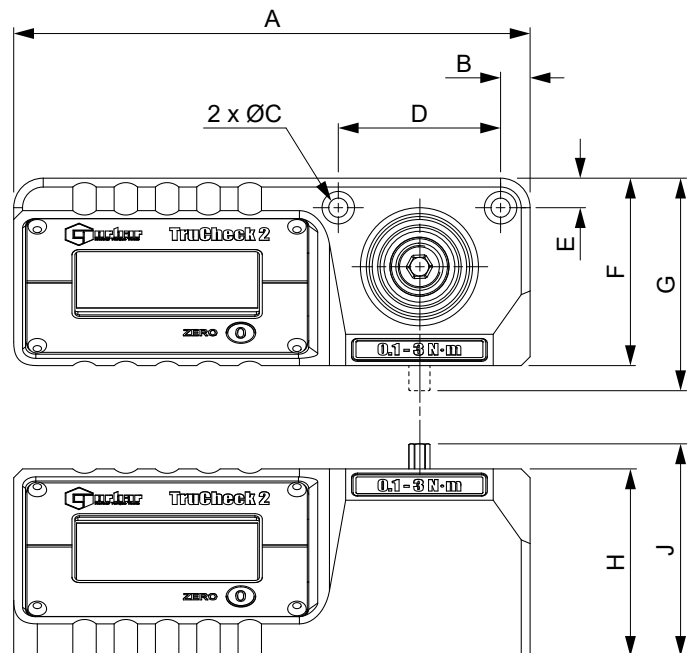

NOTE: The male hexagon on the 3 N·m and 10 N·m models is vertically aligned. The 30 N·m model male hexagon is horizontally aligned.



TRUCHECK™ 2 (3 - 2,100 N·m)



| | |
|--------------------|---|
| 4 | TRUCHECK 2 (3 - 2,100 N·m) |
| 43520* | TruCheck 2, 3 - 65 N·m |
| 43521* | TruCheck 2 Plus, 3 - 65 N·m |
| 43522* | TruCheck 2, 10 - 260 lbf-ft |
| 43523* | TruCheck 2 Plus, 10 - 260 lbf-ft |
| 43524* | TruCheck 2, 10 - 350 N·m |
| 43525* | TruCheck 2 Plus, 10 - 350 N·m |
| 43528 [®] | TruCheck 2, 40 - 800 lbf-ft |
| 43529 [®] | TruCheck 2 Plus, 40 - 800 lbf-ft |
| 43530 [®] | TruCheck 2, 50 - 1,100 N·m |
| 43531 [®] | TruCheck 2 Plus, 50 - 1,100 N·m |
| 43532 [^] | TruCheck 2, 200 - 2,100 N·m |
| 43533 [^] | TruCheck 2 Plus, 200 - 2,100 N·m |
| 29191 | ¾" sq. dr. adapter for 27 mm male hexagon |
| 29403 | 1" sq. dr. adapter for 27 mm male hexagon |

* 43520 and 43521 supplied with ⅜" female square drive
 + 43522, 43523, 43524 and 43525 supplied with ½" female square drive
 ® 43528, 43529, 43530 and 43531 supplied with 27 mm male hexagon plus ¾" female sq. dr. adapter
 ^ 43532 and 43533 supplied with 27 mm male hexagon plus 1" female sq. dr. adapter.

| | |
|--------------|---|
| 12 | |
| TCACC.CW | UKAS accredited calibration all sizes - clockwise |
| TCACC.CW+CCW | UKAS accredited calibration all sizes - clockwise and counter-clockwise |

NOTE: If you order a UKAS accredited calibration, this certificate will be provided in place of the traceable calibration certificate and over the operating range as indicated on the device.



TruCheck™ 2 Plus 1100 shown with a Power Tool Test Fixture (not included - see page page 103) allowing for cost-effective checking of power tools

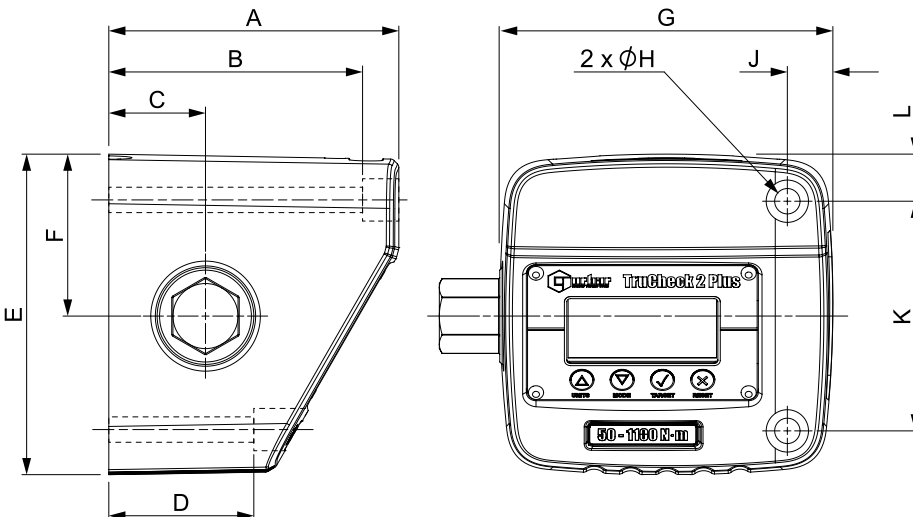

TruCheck™ 2 Plus
1,100 N·m



TruCheck™ 2 Plus
350 N·m

TruCheck™ 2 Report Print Software

The Norbar report print software allows you to test the output of a torque wrench. The software will capture readings from your TruCheck™ 2 instrument and save them in a database and allow you to produce a customised report that can be shared or stored.

| Model | TruCheck 2/Plus 3 - 65 N·m 10 - 260 lbf-ft 10 - 350 N·m | TruCheck 2/Plus 40 - 800 lbf-ft 50 - 1,100 N·m 200 - 2,100 N·m |
|-----------------|--|---|
| Part Number | 43520, 43521, 43522, 43523, 43524, 43525 | 43528, 43529, 43530, 43531, 43532, 43533 |
| Dimensions (mm) | A | 110 |
| | B | 95 |
| | C | 40 |
| | D | 50 |
| | E | 117 |
| | F | 59 |
| | G | 138 |
| | ØH | 10.5 |
| J | 19 | |
| K | 80 | |
| L | 19 | |
| Weight (kg) | 2.6 | 3.5 |



T-BOX™ 2



61908 TDMS USB Flash Drive

The T-Box™ 2 utilises its powerful processor to provide a seamless and complete torque data collection package. This is capable of tool calibrations, data logging, simultaneous transducer connections and archiving to your PC. As standard T-Box™ 2 is supplied with a UKAS accredited bi-directional calibration certificate recording each input as an independent channel.

- Instrument accuracy of $\pm 0.05\%$ ($\pm 0.1\%$ when below 10% of transducer capacity)
- System accuracy with a typical Norbar transducer, $\pm 0.5\%$ from 20% of transducer capacity
- 5 digit resolution when used with any Norbar transducer
- Features a 10.1" multi-touch screen display with on-screen graphic icons for simple and easy tool navigation and selection
- Features hardened and impact resistant glass helping to prevent chips and scratches appearing on the screen's surface
- 2 transducer ports gives you the ability to perform 2 tasks simultaneously e.g. graphing & measuring
- Two task windows allows simultaneous working. Measure against a target while graphing the cycle, take readings from two transducers simultaneously, capture two different graphs at the same time or manage and review readings as they are captured
- The T-Box™ 2 can capture graphs up to 325 Hz, offering the ability to analyse fast moving transients
- User configurable to allow a selection of Torque, Torque and Angle, rate targets and the ability to set thresholds
- Ability to predefine multiple targets
- 2 USB ports, 1 RS-232 serial port and 2 independently configurable ancillary ports
- Includes 6 modes for torque tool measurement: Track, Click, Dial & Electronic, Stall, Screwdriver and Hydraulic
- File browser/manager for internal storage and USB management giving the user greater ease and flexibility in managing multiple files and folders
- Can export readings and graphs to CSV and JSON format allowing for 3rd party software integration
- Ability to network via USB adapter
- Continuous output of up to 100 readings per second via RS-232 or USB virtual serial devices
- Fast CPU frequency up to 2.3 GHz
- Large capacity memory of 120 GB SSD storage
- 4GB RAM allows for smooth and seamless operation
- Bench stand supplied as standard with an adjustable viewing angle
- Rear panel features 100 mm x 100 mm VESA mounting holes, allowing for easy wall mounting or the use of third party stands / arms
- Software can be updated remotely, without the need to return the product to Norbar
- Fully supports the use of a keyboard and mouse (not supplied)

4 T-BOX 2

43542 T-Box 2 Instrument with TDMS Software



Displaying 2 transducer readings simultaneously

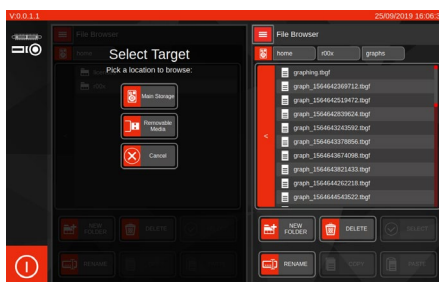

Storage destination (left) file browser (right)

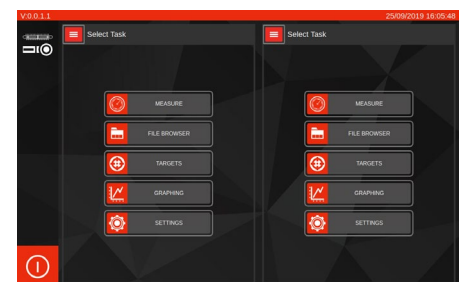

Home menu for 2 separate windows



T-BOX™ 2



The Analogue Board (AnB) Module are more than just simple transducer inputs, they are distinct computing modules that operate independently containing their own states and settings. The T-Box™ 2 comes equipped with 2 of these modules inbuilt (image to the right). A good application for this would be the calibration of hydraulic torque wrenches where one AnB is configured to read a torque transducer and the other is configured to read a pressure transducer, allowing the user to build up a torque versus pressure graph using one instrument. See page 107 for a schematic example.

For situations where more than 2 transducers are required an external AnB module (43543 shown to the left) is available, this would also offer the advantage of being able to place the transducer at a distance to your T-Box™ 2 with no detrimental effects on the measurement signal.



Software version 1.0.3.1 available

- Ability to set up new graph pre-sets and defaults, saving the user time
- New graphing settings allows the user to set a maximum graph duration to stop data capture after a designated time
- Can link targets with the ability to delete previously captured result
- Intelligent target file history memorises the last-used files for individual AnB modules improving convenience when working with two transducers with different sets of targets at once
- Ability to enable or disable implicit AnB selection allowing for greater control when setting or clearing targets in AnB modules
- Users can now toggle serial data output on/off per AnB allowing the ability to suppress output from one AnB and leaving only the data stream from the AnB of interest
- Progressive Reset lets you sweep through a series of Linked Targets for the purpose of rapidly calibrating hydraulic wrenches or gearboxes, (peak-type modes only)

| | |
|-------|--------------------|
| 4 | AnB MODULE |
| 43543 | T-Box 2 AnB Module |

- Broadcast Capture Triggers lets you trigger capture of a reading on the neighbouring AnB when a reading capture is made on the target (peak-type and click modes only; peak-type modes require Progressive Reset to be enabled)
- Combining Progressive Reset and Broadcast Capture Triggers with Linked Targets to capture hydraulic wrench torque at a series of desirable pressure levels for rapid hydraulic wrench calibration. This approach can dramatically reduce calibration times (for instance, from several minutes to under 1 minute)
- Capture large numbers of readings with more fluidity than ever before thanks to performance optimisations in the user interface
- Simplified update procedure allowing for updates within T-Box™ 2 User Interface without the requirement of a keyboard

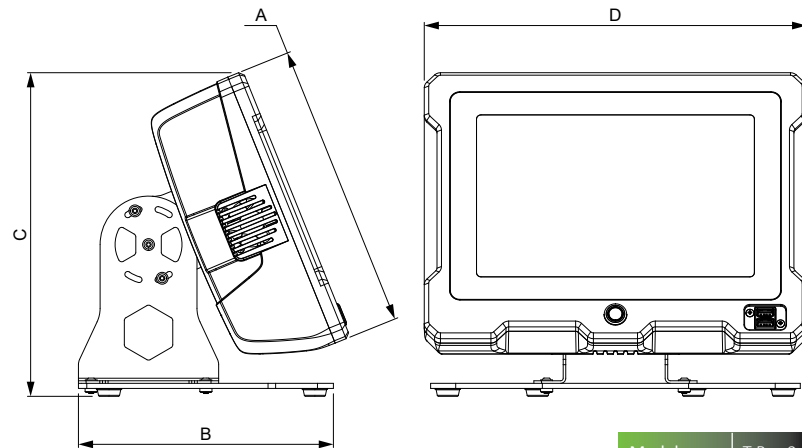

Displaying transducer reading alongside target selection

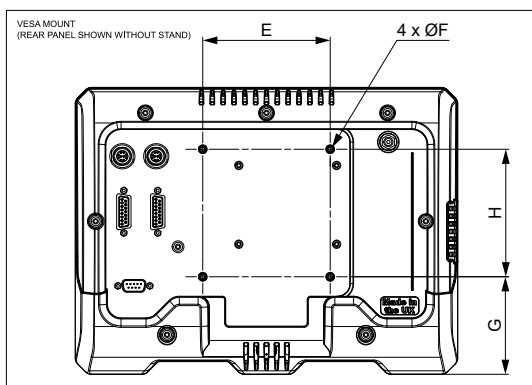

T-Box™ 2 back panel allows for 2 transducers to connect simultaneously, 1 RS-232 serial port and 2 ancillary ports

| | | |
|-----------------|---------|-----|
| Model | T-Box 2 | |
| Part Number | 43542 | |
| Dimensions (mm) | A | 225 |
| | B | 200 |
| | C | 254 |
| | D | 300 |
| | E | 100 |
| | ØF | M4 |
| | G | 76 |
| | H | 100 |
| Weight (kg) | 5.2 | |



T-Box™ 2 at the center of a test bench for manual torque wrenches, powered torque tools and hydraulic torque wrenches



TORQUE SCREWDRIVER TESTER (TST)



Calibration details



The Torque Screwdriver Tester (TST) combines simplicity and functionality to provide a high quality instrument for the testing and calibration of low capacity torque tools.

The TST is supplied as standard with a UKAS accredited torque calibration certificate in CW direction for the complete system i.e. Supplied with Instrument certificate and internal transducer system certificate.

Featuring an internal transducer complete with Rundown Fixture, the TST is available in 3 torque ranges, 0.04 to 2 N·m, 0.5 to 10 N·m and 1.25 to 25 N·m. Class 1 system accuracy over its Primary range ($\pm 0.5\%$ of reading from 20% to 100% of full scale).

What makes the TST genuinely versatile is the interface for an external transducer. This interface, accessed by a 2 way switch on the TST, allows the connection of any transducer from Norbar's Smart range and most mV/V calibrated transducers from Norbar or other manufacturers.

- Instrument accuracy of $\pm 0.05\%$ ($\pm 0.1\%$ when below 10% of transducer capacity)
- System accuracy with internal transducer or a typical external Norbar transducer, $\pm 0.5\%$ from 20% of transducer capacity
- Pictorial display panel for easy mode selection
- Limit detection with low, pass and fail indication. Up to 12 target values can be set
- Digital limit state output for control of external tools
- Operation from fast charge internal battery pack (maximum time of 3 hours 20 minutes for full charge) or a.c. supply (90 to 264 Volts)
- RS-232-C serial data interface for connection to a printer or PC. Continuous RS-232 output when used in Track mode (up to 11 readings per second)
- Pulse count feature in Impulse mode and Clutch Tool mode
- Smart intelligence for transducer recognition
- Memory for calibration details of 20 non-Smart mV/V calibrated transducers
- Analogue output allows the instrument to be used as part of a process control system for performance analysis
- User-selectable frequency response for each mode of operation
- All user-selectable features have password protection. The instrument can be issued to users with only the required modes of operation and units of measure enabled. This feature can virtually eliminate operator induced errors
- $\frac{1}{4}$ " female hex to $\frac{1}{4}$ " female square adaptor comes supplied as standard



| 4 | TST SERIES 2 |
|-------|-----------------------|
| 43212 | TST 2, 0.04 - 2 N·m |
| 43213 | TST 10, 0.5 - 10 N·m |
| 43214 | TST 25, 1.25 - 25 N·m |

| 12 | |
|---------|--|
| TST.CCW | UKAS-accredited counter-clockwise calibration when ordered with new unit |

Above part numbers exclude Transducer lead for external transducer (see page 93).

TST is supplied complete with a Rundown Fixture for joint simulation. Additional rundowns are available see page 96.

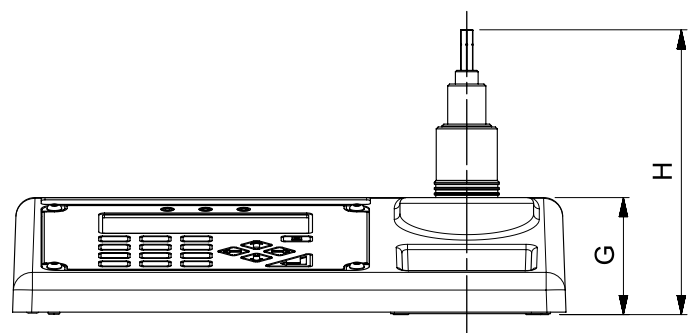
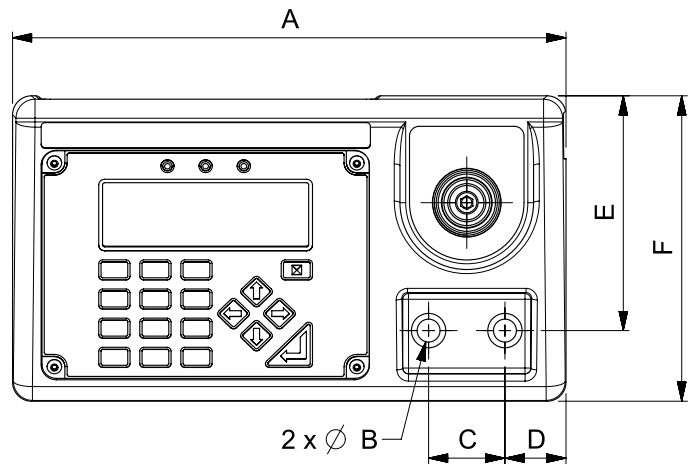

| Model | All Models | |
|-----------------|-------------------------|-----|
| Part Number | 43212 43213 43214 | |
| Dimensions (mm) | A | 290 |
| | ØB | 10 |
| | C | 40 |
| | D | 32 |
| | E | 123 |
| | F | 160 |
| | G | 61 |
| | H | 149 |
| Weight (kg) | 4.7 | |



TORQUE TOOL TESTER (TTT)



The Torque Tool Tester (TTT) shares all of the extensive features of the Torque Screwdriver Tester (TST) except that it has no internal transducer. Instead, the TTT offers not one but three external transducer interfaces allowing any three transducers to be simultaneously connected. Selection between the transducers is made by a rotary switch at the back of the instrument case.

The TTT is supplied as standard with a UKAS accredited calibration certificate in CW direction.

Any transducer from Norbar's Smart range and most mV/V calibrated transducers from Norbar or other manufacturers can be connected to the TTT. The Smart feature means that once a transducer has been connected, the instrument will automatically recognise calibration details such as mV/V output, serial number and capacity.

- Instrument accuracy of $\pm 0.05\%$ ($\pm 0.1\%$ when below 10% of transducer capacity)
- System accuracy with a typical Norbar transducer, $\pm 0.5\%$ from 20% of transducer capacity
- Pictorial display panel for easy mode selection
- Limit detection with low, pass and fail indication. Up to 12 target values can be set
- Digital limit state output for control of external tools
- Operation from fast charge internal battery pack (maximum time of 3 hours 20 minutes for full charge) or a.c. supply (90 to 264 Volts)
- RS-232-C serial data interface for connection to a printer or PC. Continuous RS-232 output when used in Track mode (up to 11 readings per second)
- Pulse count feature in Impulse mode and Clutch Tool mode
- Smart intelligence for transducer recognition, now displays transducer capacity, units and Serial Number
- Memory for calibration details of 20 non-Smart mV/V calibrated transducers
- Analogue output allows the instrument to be used as part of a process control system for performance analysis
- User-selectable frequency response for each mode of operation
- All user-selectable features have password protection. The instrument can be issued to users with only the required modes of operation and units of measure enabled. This feature can virtually eliminate operator induced errors
- Peak memory modes can now be configured to have auto reset (previously only manual reset was possible)
- Series 3 users can set up their own measurement units, making it possible to interface with non-torque transducers, for example load or pressure



| | |
|-------|----------------|
| 4 | TTT SERIES 3 |
| 43228 | TTT Instrument |

| | |
|---------|--|
| 12 | |
| TTT.CCW | UKAS-accredited counter-clockwise calibration when ordered with new unit |

Above part number excludes Transducer leads (see page 92)



| Model | All Models | |
|-----------------|------------|-----|
| Part Number | 43228 | |
| Dimensions (mm) | A | 152 |
| | B | 181 |
| | C | 200 |
| Weight (kg) | 4.8 | |

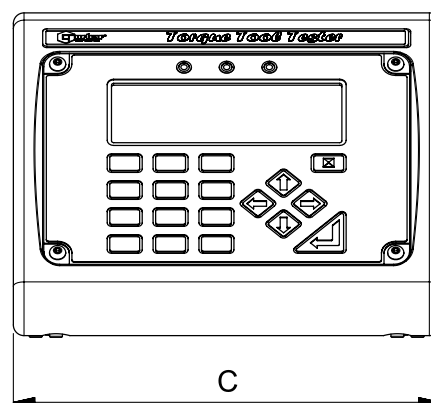
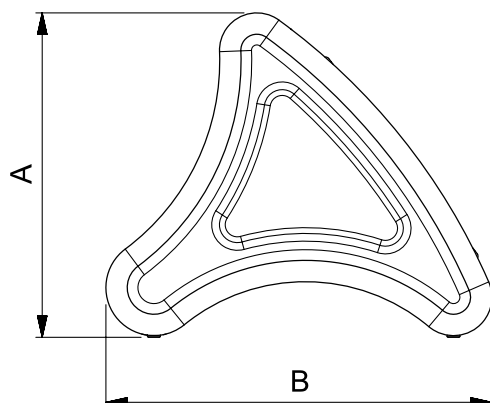



PROFESSIONAL TORQUE TESTER (PRO-TEST)



Calibration details



The Professional Torque Tester (Pro-Test) - Series 2, is an accurate, highly specified and easy to operate instrument for testing and calibrating all types of torque wrench.

The Pro-Test is supplied as standard with a UKAS accredited calibration certificate.

- Pro-Test is priced to make in-house testing a viable proposition even for the smaller industrial and automotive torque wrench user
- Guaranteed classification to BS7882:2017, Class 1 or better over the primary calibration range (20% to 100% of full scale), Class 2 or better over the secondary calibration range (lowest calibrated value to 20% of full scale). Class 1 equates to $\pm 0.5\%$ of reading
- Three essential operating modes allow the Pro-Test to be used with all torque wrench types 'Track' displays the live value, 'Peak Memory' records the highest value and 'First Peak Memory' records the first peak of torque (for click type torque wrenches). Both memory modes can be used with manual or automatic reset
- Large backlit display is easily visible from a distance and in poor light
- Display and transducer are hard-wired together with a 600 mm cable
- All common units of torque measurement are included
- Pictorial mode selection incorporated for ease of use
- User can select the language they wish to work in (most European languages are included)
- Transducer can be mounted for torque wrench operation in the horizontal or vertical plane
- RS-232-C is included for the output of reading to a printer, PC, data capture unit, SPC software etc
- Optional mounting plate gives greater flexibility of mounting options
- All user-settable parameters are menu selectable from the front panel
- Supplied in a robust carry case with a data transfer lead to connect to a PC or printer
- All transducers are supplied as standard with a UKAS accredited calibration certificate in CW direction. For additional counter-clockwise direction order: Part No. PROTEST.CCW



| 4 | PRO-TEST SERIES 2 |
|-------|-------------------------------|
| 43218 | Pro-Test 60, 1.2 - 60 N·m |
| 43219 | Pro-Test 400, 8 - 400 N·m |
| 43220 | Pro-Test 1500, 30 - 1,500 N·m |

| 4 | ANCILLARY PRODUCTS FOR PRO-TEST |
|---------------|----------------------------------|
| 62198.BLK9005 | Mounting Bracket |
| 60253 | 12v DC Power Supply for Series 2 |
| 29190 | 1" x 36 mm Socket |
| 29179 | ¾" x 36 mm Socket |
| 29143 | ½" x 36 mm Socket |
| 29083 | ⅜" x 36 mm Socket |

| 12 | |
|-------------|--|
| PROTEST.CCW | Counter-clockwise calibration when ordered with new unit |



| Model | Pro-Test 60 | Pro-Test 400 | Pro-Test 1500 |
|--------------------|---|---|-----------------|
| Part Number | 43218 | 43219 | 43220 |
| Socket(s) provided | ¼" to 10 mm Hex ⅜" to 10 mm Hex ½" to 10 mm Hex | ⅜" to 22 mm Hex ½" to 22 mm Hex ¾" to 22 mm Hex | ¾" to 36 mm Hex |
| Dimensions (mm) | ØA | 12 | 12 |
| | B | 55 | 55 |
| | C | 183 | 183 |
| | D | 18 | 18 |
| | E | 70 | 70 |
| | F | 185 | 185 |
| | G | 233 | 233 |
| | H | 106 | 106 |
| Weight (kg) | 6.3 | 6.4 | 7.3 |

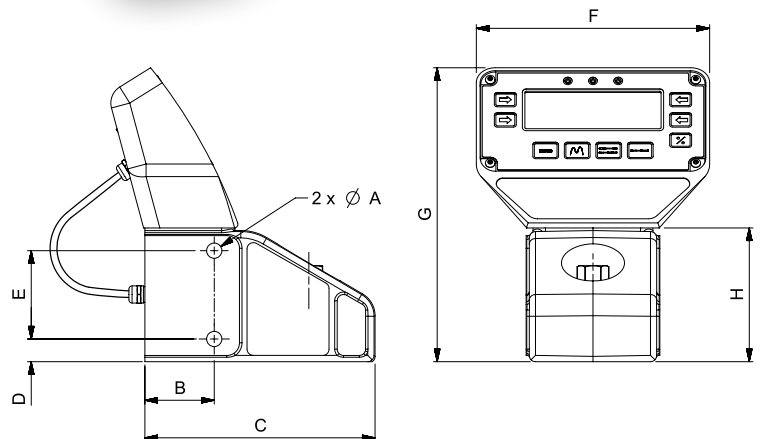



SPARES FOR INSTRUMENTATION PRODUCTS

PART NUMBER SUFFIX SYSTEM

| 8 | SPARES FOR INSTRUMENTATION PRODUCTS |
|-------|--|
| 38876 | Rechargeable Battery Pack for Pro-Log, TST & TTT |
| 29610 | ¼" Female - ½" Male Sleeve Adaptor |
| 29611 | ½" Female - ¾" Male Sleeve Adaptor |
| 29612 | ½" Female - 1" Male Sleeve Adaptor |
| 29613 | ¾" Female - 1" Male Sleeve Adaptor |
| 29614 | ¾" Female - ½" Male Sleeve Adaptor |

| 4 | SERIAL DATA LEAD KIT |
|-------|----------------------|
| 60248 | Serial Data Lead Kit |

Note: Serial Data Lead Kit is not suitable for use with HE Instrument and TruCheck™ 2

60259 | USB to Serial Data Lead (Does not work with USM-3)
 This kit enables Norbar 'CE Marked' instruments (Post January 1996 ETS, TWA and DTS plus all Pro-Test, TST and TTT) to connect to most PCs.

Transducers can be ordered for use with Norbar's current range of instruments (TST, TTT, TTL-HE and T-Box™ 2), and as Industry Standard (mV/V calibrated) for certain display instruments from other manufacturers.

A part number suffix system is used to identify the type of calibration required. For example, a 1,000 N·m Static Transducer for use with a TTT instrument would become part number 50772.LOG.

| SUFFIX | USAGE | CERTIFIED IN |
|--------|---|--------------|
| .LOG | TST, TTT, TTL-HE & T-Box™ 2 | Torque Units |
| .IND | Instruments of non Norbar manufacture (check with Norbar for suitability) and TST, TTT, TTL-HE & T-Box™ 2 | mV/V |

Where the transducer suffix .LOG is used, the transducer is calibrated with an instrument, as a system, a calibration certificate is provided in torque units. A full scale mV/V figure is also supplied.

STATIC TRANSDUCER BENCH STANDS

| 4 | BENCH STANDS FOR STATIC TORQUE TRANSDUCERS |
|----------------|--|
| 50211 | Small frame size (10 N·m) ¼" sq. |
| 50212 | Small frame size (50 N·m) ⅜" sq. |
| 50213 | Small frame size (100/250 N·m) ½" sq. |
| 50220 | Large frame size (250/500 N·m) ¾" sq. |
| 50221 | Large frame size (1,000/1,500 N·m) 1" sq. |
| 50127.BLK9005* | Extra large size (7,000 N·m) 1½" sq. |
| 52014 | ¼" Insert for Small Bench Stands |
| 52015 | ⅜" Insert for Small Bench Stands |
| 52016 | ½" Insert for Small Bench Stands |
| 52017 | ¾" Insert for Large Bench Stands |
| 52018 | 1" Insert for Large Bench Stands |

* Dimensions available on request



Bench stands ensure the correct mounting of Norbar's Static Torque Transducers up to 7,000 N·m (5,000 lbf·ft).

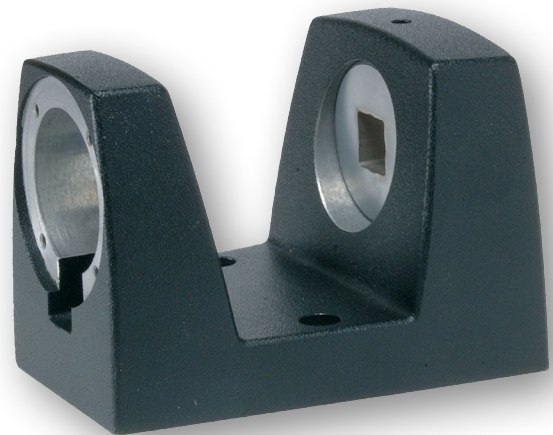

| Model | Small Frame Size | Large Frame Size |
|-----------------|-------------------------|------------------|
| Part Number | 50211 50212 50213 | 50220 50221 |
| Dimensions (mm) | A | 70 |
| | B | 120 |
| | C | 150 |
| Weight (kg) | 0.8 | 2.5 |

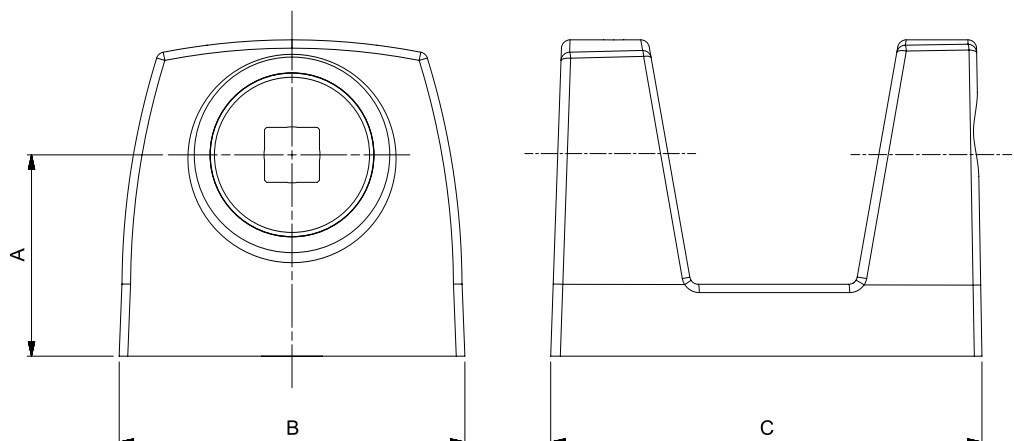



STATIC TRANSDUCERS



Calibration details



The accuracy and quality of the Norbar Static Torque Transducers has made them the first choice of many calibration laboratories throughout the world. Up to 5,000 N·m (5,000 lbf·ft) classified to BS7882:2017, typically better than Class 1 for the primary classification range ($\pm 0.5\%$ of reading from 20% to 100% of full scale).

- Robust, heat treated, alloy steel torsion shaft design
- Designed to ignore non-torsional forces
- Operates in clockwise and counter-clockwise directions
- Calibration up to 100,000 N·m with a UKAS accredited certificate
- For transducers rated at over 7,000 N·m consult with your Norbar technical sales representative for accuracy statements

- Calibrated in clockwise direction as standard. Counter-clockwise provided on request
- Smart transducers have a built in memory circuit which contains essential information about the transducer. This information can be read by Norbar's TST, TTT, TTL-HE & T-Box™ 2 instruments meaning that when the transducer is connected, it is immediately recognised and ready for use

Static Transducers ¼" through to 1"

| 4 | STATIC TRANSDUCERS - 0.1 - 1,500 N·m | |
|------------|--------------------------------------|--------|
| 50587.xxx* | 0.1 - 1 N·m | ¼" M/F |
| 50588.xxx | 0.25 - 2.5 N·m | ¼" M/F |
| 50589.xxx | 0.5 - 5 N·m | ¼" M/F |
| 50590.xxx | 1 - 10 N·m | ¼" M/F |
| 50591.xxx | 2.5 - 25 N·m | ⅜" M/F |
| 50592.xxx | 5 - 50 N·m | ⅜" M/F |
| 50593.xxx | 10 - 100 N·m | ½" M/F |
| 50594.xxx | 25 - 250 N·m | ½" M/F |
| 50701.xxx | 25 - 250 N·m | ¾" M/F |
| 50849.xxx | 35 - 350 N·m | ½" M/F |
| 50596.xxx | 50 - 500 N·m | ¾" M/F |
| 50772.xxx | 100 - 1,000 N·m | 1" M/F |
| 50766.xxx | 150 - 1,500 N·m | 1" M/F |

| 4 | STATIC TRANSDUCERS - 0.1 - 1,000 lbf·ft | |
|-----------|---|--------|
| 50611.xxx | 0.1 - 1 lbf·ft | ¼" M/F |
| 50615.xxx | 0.5 - 5 lbf·ft | ¼" M/F |
| 50618.xxx | 1 - 10 lbf·ft | ¼" M/F |
| 50620.xxx | 2.5 - 25 lbf·ft | ⅜" M/F |
| 50836.xxx | 5 - 50 lbf·ft | ½" M/F |
| 50624.xxx | 10 - 100 lbf·ft | ½" M/F |
| 50625.xxx | 25 - 250 lbf·ft | ½" M/F |
| 50702.xxx | 25 - 250 lbf·ft | ¾" M/F |
| 50627.xxx | 50 - 500 lbf·ft | ¾" M/F |
| 50773.xxx | 100 - 1,000 lbf·ft | 1" M/F |

| 4 | STATIC TRANSDUCERS - 1 - 1,000 lbf·in | |
|------------|---------------------------------------|--------|
| 50610.xxx* | 1 - 10 lbf·in | ¼" M/F |
| 50612.xxx | 2.5 - 25 lbf·in | ¼" M/F |
| 50614.xxx | 5 - 50 lbf·in | ¼" M/F |
| 50617.xxx | 10 - 100 lbf·in | ¼" M/F |
| 50619.xxx | 25 - 250 lbf·in | ⅜" M/F |
| 50621.xxx | 50 - 500 lbf·in | ⅜" M/F |
| 50623.xxx | 100 - 1,000 lbf·in | ½" M/F |

| 4 | STATIC TRANSDUCERS - 10 - 100 ozf·in | |
|------------|--------------------------------------|--------|
| 50609.xxx* | 10 - 100 ozf·in | ¼" M/F |

xxx Indicates .LOG or .IND versions, please see page 89.

* .LOG versions not suitable for use with TST, TTT or TTL-HE, purchased pre Feb 2016.

+ UKAS accredited calibration up to 80,000 lbf·ft. A non-accredited value at 100,000 lbf·ft is extrapolated and provided for reference only.

| Model | ¼" M/F | ⅜" M/F | ½" M/F | ¾" M/F | 1" M/F | | |
|-------------|--|---|---|--|-------------------------------------|-----|-----|
| Part Number | 50587.xxx 50588.xxx 50589.xxx 50590.xxx 50611.xxx 50615.xxx 50618.xxx 50610.xxx 50612.xxx 50614.xxx 50617.xxx 50609.xxx | 50591.xxx 50592.xxx 50620.xxx 50619.xxx 50621.xxx | 50593.xxx 50594.xxx 50849.xxx 50836.xxx 50624.xxx 50625.xxx 50623.xxx | 50701.xxx 50596.xxx 50702.xxx 50627.xxx | 50772.xxx 50766.xxx 50773.xxx | | |
| | Dimensions (mm) | ∅A | 36 | 36 | 36 | 54 | 54 |
| | | B | 33 | 33 | 33 | 42 | 42 |
| | | C | 86 | 90 | 93 | 142 | 147 |
| | | D | 10 | 13 | 16 | 24 | 29 |
| | | E | 30 | 34 | 37 | 46 | 51 |
| | | F | 6.5 | 10 | 13 | 22 | 26 |
| | Weight (kg) | 0.6 | 0.6 | 0.6 | 1.5 | 1.7 | |

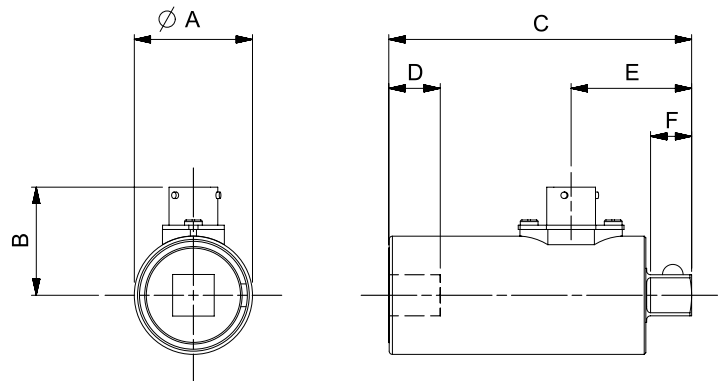

| 12 | TD2.CCW | |
|----|---|--|
| | Alternative calibration direction for transducers up to 1,500 N·m / 1,000 lbf·ft when ordered with new unit | |

| 12 | STATIC TRANSDUCERS | |
|----|--------------------|---|
| | SECCAL.CW | Secondary calibration in one direction on static transducers with 2½" square drives to extend the range below 10% of the rated capacity, when ordered with new unit |

| | | |
|--|---------------|--|
| | SECCAL.CW+CCW | Secondary calibration in two directions on static transducers with 2½" square drives to extend the range below 10% of the rated capacity, when ordered with new unit |
|--|---------------|--|

| | | |
|--|------------------|--|
| | ADDCALPOINTS.NEW | Additional calibration steps below 10% of rated capacity to 2% for transducers up to 7,000 N·m (5,000 lbf·ft) when ordered with new unit |
|--|------------------|--|



STATIC TRANSDUCERS



Calibration details

Static Transducers 1½" through to 3½" Male to Female (M/F)

| 4 | STATIC TRANSDUCERS - 250 - 7,000 N·m | |
|-----------|--------------------------------------|---------|
| 50703.xxx | 250 - 2,500 N·m | 1½" M/F |
| 50791.xxx | 300 - 3,000 N·m | 1½" M/F |
| 50599.xxx | 500 - 5,000 N·m | 1½" M/F |
| 50669.xxx | 700 - 7,000 N·m | 1½" M/F |

| 4 | STATIC TRANSDUCERS - 250 - 5,000 lbf-ft | |
|-----------|---|---------|
| 50704.xxx | 250 - 2,500 lbf-ft | 1½" M/F |
| 50630.xxx | 500 - 5,000 lbf-ft | 1½" M/F |

| 4 | STATIC TRANSDUCERS - 1,000 - 100,000 N·m | |
|-----------|--|---------|
| 50776.xxx | 1,000 - 10,000 N·m | 2½" M/F |
| 50797.xxx | 2,500 - 25,000 N·m | 2½" M/F |
| 50781.xxx | 5,000 - 50,000 N·m | 2½" M/F |
| 50783.xxx | 8,000 - 80,000 N·m | 3½" M/F |
| 50816.xxx | 10,000 - 100,000 N·m | 3½" M/F |

| 4 | STATIC TRANSDUCERS - 1,000 - 60,000 lbf-ft | |
|-----------|--|---------|
| 50777.xxx | 1,000 - 10,000 lbf-ft | 2½" M/F |
| 50798.xxx | 2,500 - 25,000 lbf-ft | 2½" M/F |
| 50799.xxx | 3,000 - 30,000 lbf-ft | 2½" M/F |
| 50782.xxx | 6,000 - 60,000 lbf-ft | 3½" M/F |

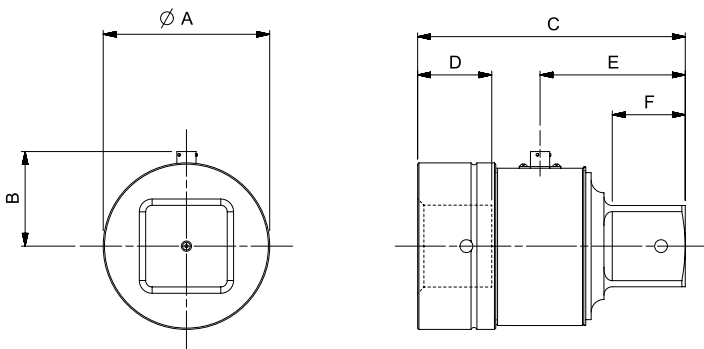

| Model | 1½" M/F | 2½" M/F | 3½" M/F | |
|-----------------|--|--|-------------------------------------|-----|
| Part Number | 50703.xxx 50791.xxx 50599.xxx 50669.xxx 50704.xxx 50630.xxx | 50776.xxx 50797.xxx 50781.xxx 50777.xxx 50798.xxx 50799.xxx | 50783.xxx 50816.xxx 50782.xxx | |
| Dimensions (mm) | ØA | 95 | 130 | 160 |
| | B | 59 | 80 | 107 |
| | C | 160 | 209 | 292 |
| | D | 41 | 59 | 91 |
| | E | 85 | 114 | 147 |
| | F | 38 | 57 | 76 |
| Weight (kg) | 4.5 | 11.5 | 16.5 | |

| 12 | |
|----------|--|
| TD5.CCW@ | Alternative calibration direction for transducers from 1,501 - 7,000 N·m / 1,001 - 5,000 lbf-ft when ordered with new unit |
| TD3.CCW+ | Alternative calibration direction for transducers from 7,001 - 100,000 N·m / 5,001 - 100,000 lbf-ft when ordered with new unit |

Static Transducers 2½" through to 3½" Male to Male (M/M)

| 4 | STATIC TRANSDUCERS - 2,500 - 100,000 N·m | |
|-----------|--|---------|
| 50603.xxx | 2,500 - 25,000 N·m | 2½" M/M |
| 50794.xxx | 5,000 - 50,000 N·m | 3½" M/M |
| 50796.xxx | 10,000 - 100,000 N·m | 3½" M/M |

| 4 | STATIC TRANSDUCERS - 2,500 - 100,000 lbf-ft | |
|------------|---|---------|
| 50635.xxx | 2,500 - 25,000 lbf-ft | 2½" M/M |
| 50795.xxx | 5,000 - 50,000 lbf-ft | 3½" M/M |
| 50637.xxx+ | 10,000 - 100,000 lbf-ft | 3½" M/M |

| 4 | STATIC TRANSDUCERS - 15,000 - 200,000 N·m | |
|---|---|---------|
| - | 15,000 - 150,000 N·m | 4½" M/M |
| - | 20,000 - 200,000 N·m | 4½" M/M |

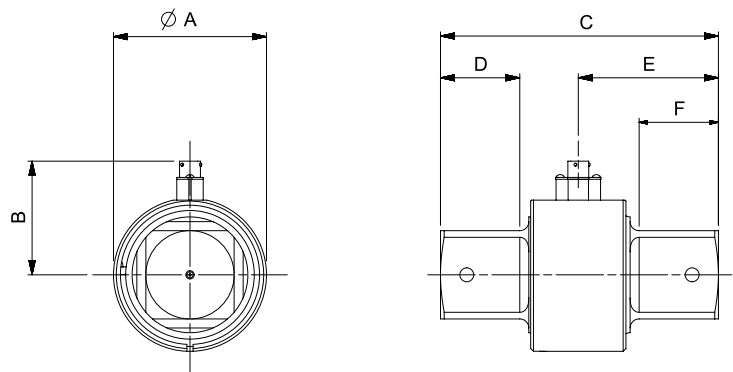

| Model | 2½" M/M | 3½" M/M | |
|-----------------|------------------------|--|-----|
| Part Number | 50603.xxx 50635.xxx | 50794.xxx 50796.xxx 50795.xxx 50637.xxx | |
| Dimensions (mm) | ØA | 110 | 165 |
| | B | 82 | 95 |
| | C | 200 | 271 |
| | D | 57 | 76 |
| | E | 100 | 135 |
| | F | 57 | 76 |
| Weight (kg) | 11.5 | 16.5 | |



ROTARY TRANSDUCERS



Rotary transducers are designed to measure the torque from continuously rotating shafts such as impulse power tools and certain non-impulse tools with a severe clutch action.

This range offers class-leading performance with impulse tools and will be supplied with a UKAS accredited calibration certificate from Norbar's laboratory.

These transducers are known as Smart transducers. They have built-in intelligence in the form of a memory circuit which contains essential information about the transducer which can be read by the appropriate type of instrument (TST, TTT, TTL-HE & T-Box™ 2), thus reducing set-up time.

They will also work with instruments that cannot read the memory information, by inputting the relevant calibration details manually.

Note: Not for use with Impact Tools.

Angle measurement also available.



| 4 | ROTARY TRANSDUCERS |
|-----------|---------------------------------|
| 50708.xxx | 0.25 - 5 N·m ¼" M/F Hex |
| 50709.xxx | 1 - 20 N·m ¼" M/F Hex |
| 50710.xxx | 1 - 20 N·m ¼" M/F sq. dr. |
| 50719.xxx | 0.75 - 15 lbf·ft ¼" M/F sq. dr. |
| 50711.xxx | 3.75 - 75 N·m ⅜" M/F sq. dr. |
| 50720.xxx | 2.5 - 50 lbf·ft ⅜" M/F sq. dr. |
| 50712.xxx | 10 - 200 N·m ½" M/F sq. dr. |
| 50721.xxx | 7.5 - 150 lbf·ft ½" M/F sq. dr. |
| 50713.xxx | 12.5 - 250 N·m ¾" M/F sq. dr. |

| 4 | ROTARY TRANSDUCERS |
|-----------|----------------------------------|
| 50722.xxx | 10 - 200 lbf·ft ¾" M/F sq. dr. |
| 50714.xxx | 25 - 500 N·m ¾" M/F sq. dr. |
| 50723.xxx | 15 - 300 lbf·ft ¾" M/F sq. dr. |
| 50715.xxx | 75 - 1,500 N·m 1" M/F sq. dr. |
| 50724.xxx | 50 - 1,000 lbf·ft 1" M/F sq. dr. |

| 12 | |
|---------|-------------------------------|
| TD2.CCW | Counter-clockwise calibration |

Angle options available, contact Norbar.

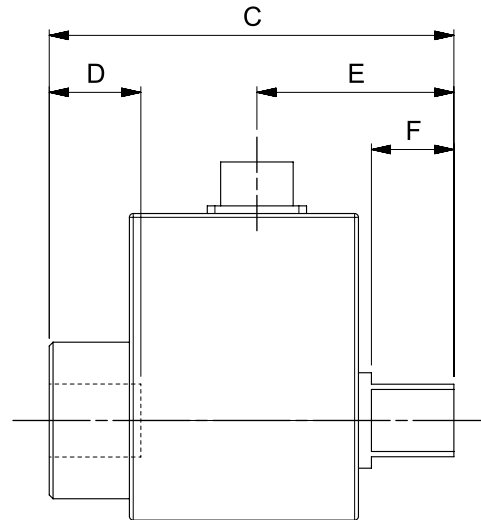
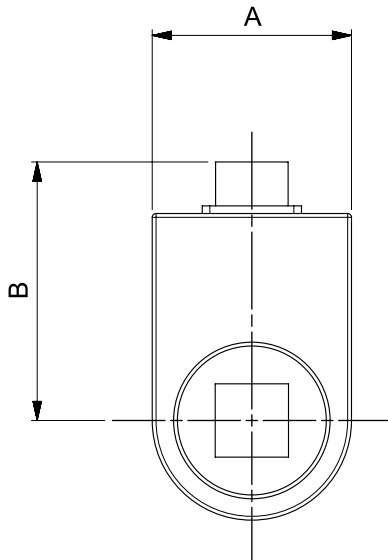

| Model | ¼" M/F Hex | ¼" M/F sq. dr. | ⅜" M/F sq. dr. | ½" M/F sq. dr. | ¾" M/F sq. dr. | 1" M/F sq. dr. | |
|-----------------|------------------------|------------------------|------------------------|------------------------|--|------------------------|-----|
| Part Number | 50708.xxx 50709.xxx | 50710.xxx 50719.xxx | 50711.xxx 50720.xxx | 50712.xxx 50721.xxx | 50713.xxx 50714.xxx 50722.xxx 50723.xxx | 50715.xxx 50724.xxx | |
| Dimensions (mm) | A | 30 | 30 | 42 | 52 | 63 | |
| | B | 58 | 58 | 62 | 67 | 79 | |
| | C | 116 | 72 | 77 | 87 | 106 | 125 |
| | D | N/A | 10 | 13 | 16 | 24 | 29 |
| | E | 49 | 33 | 36 | 42 | 51 | 61 |
| | F | 26 | 7 | 11 | 15 | 21 | 26 |
| Weight (kg) | 0.2 | 0.2 | 0.2 | 0.4 | 0.8 | 1.5 | |



TRANSDUCER LEADS



If ordering a static, annular or rotary transducer you will also require a corresponding lead (see list below).

To comply with the latest calibration standards, most new transducer leads will have a suffix to indicate the length in centimetres.

| 4 | TRANSDUCER LEADS |
|-----------|--|
| 60216.200 | PRO-LOG, TST, TTT, T-Box XL & T-Box 2 to 10 Way Transducer for use with Norbar Rotary Transducers |
| 60217.200 | PRO-LOG, TST, TTT, T-Box XL & T-Box 2 to 6 Way Transducer for use with Norbar Static & Annular Transducers |
| 60223.200 | PRO-LOG, TST, TTT & T-Box XL to no connector |
| 60224.200 | 10 Way Transducer to no connector |
| 60225.200 | 6 Way Transducer to no connector |
| 51067.225 | ETS to Transducer (Pre 1994) + 5 way (60055) |
| 60152.225 | ETS to Transducer (Post 1994) + 5 way (60163) |

| 4 | TRANSDUCER LEADS |
|------------|---|
| 60308.400 | PRO-LOG, TST, TTT, T-Box XL & T-Box 2 to Torque & Angle Annular Transducers |
| 60308.600 | PRO-LOG, TST, TTT, T-Box XL & T-Box 2 to Torque & Angle Annular Transducers |
| 60308.1000 | PRO-LOG, TST & TTT to Torque & Angle Annular Transducers |

Other lengths can be ordered, contact Norbar for more information.

Note: The system should be calibrated with the increased length lead, as calibration may be affected.

Note: The maximum permissible cable length is 15 m for TST, TTT or T-Box™ 2 and 7 m with a T-Box™ XL. Contact Norbar for further details.

ANNULAR TRANSDUCERS



| 4 | ANNULAR TRANSDUCERS FOR 72 mm SERIES GEARBOX (PT tools only - not suitable for PTS/PTM tools) |
|---|---|
| Suitable for PT-72 mm Remote Series | |
| 50666.xxx | 100 - 1,000 N·m |
| 50667.xxx | 150 - 1,500 N·m |
| 50668.xxx | 200 - 2,000 N·m |
| Standard calibration is performed loading counter-clockwise only. | |

| 4 | ANNULAR TRANSDUCERS FOR PTS/PTM 72 |
|-----------------------------------|------------------------------------|
| Suitable for PTS/PTM-72 mm Series | |
| 50840.xxx | 100 - 1,000 N·m |
| 50841.xxx | 150 - 1,500 N·m |
| 50842.xxx | 200 - 2,000 N·m |
| 50846.LOGA | 100 - 1,000 N·m with Angle |

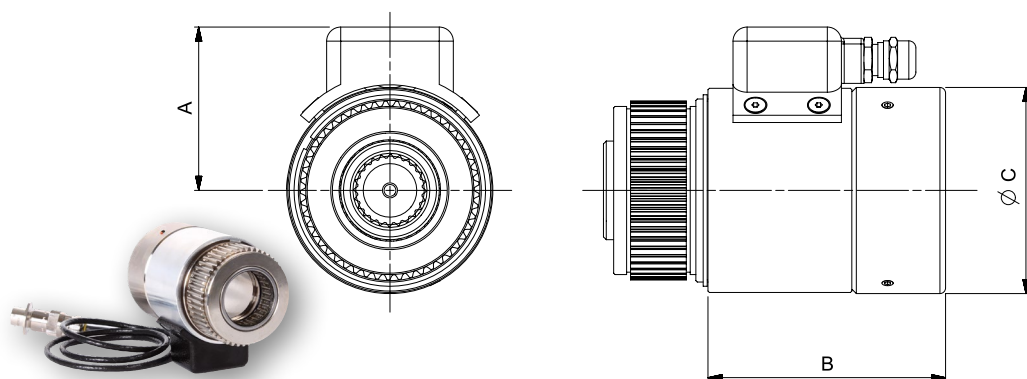

| Model | Annular Transducers for use with 72 mm Series Multipliers | Annular Transducers for use with 72 mm Series Multipliers |
|-----------------|--|---|
| Part Number | 50666.xxx 50667.xxx 50668.xxx 50840.xxx 50841.xxx 50842.xxx | 50846.LOGA |
| Dimensions (mm) | A | 58 |
| | B | 84 |
| | ∅C | 72 |
| Weight (kg) | 1.5 | 3.1 |

Torque and Angle Annular Transducer Note:

- 5,000 N·m and above include dowels on both mounting faces
- Angle resolution < 1° when used with T-Box™ 2
- CW+CCW calibration is standard
- Use 60308.xxx series lead for direct connection to T-Box™ 2 for torque and angle/turns monitoring and storage
- PT square drive and other parts may require removal to fit transducer
- All the above are standard construction. Harsh Environment models are available on request
- '.INDA' versions are available on request

Note: PTS™ and reactions with dowel holes can be supplied at an extra cost on request. Request details on PneuTorque® Type '.XD'

| 12 | ANNULAR TRANSDUCERS |
|------------------|---|
| SECCAL.CW | Secondary calibration in one direction on annular transducers for HT/PT9 & HT/PT11 to extend the range below 10% of the rated capacity, when ordered with new unit |
| SECCAL.CW+CCW | Secondary calibration in two directions on annular transducers for HT/PT9 & HT/PT11 to extend the range below 10% of the rated capacity, when ordered with new unit |
| ADDCALPOINTS.NEW | Additional calibration steps below 10% of rated capacity to 2% for transducers up to 7,000 N·m (5,000 lbf·ft) when ordered with new unit |



ANNULAR TRANSDUCERS



Calibration details



These Annular Transducers are designed to fit directly to Norbar torque multipliers and will accurately measure the torque output from the gearbox, via a display instrument (instrument supplied separately, see pages 84 - 85 & 87).

- Up to 6,000 N·m classified to BS7882:2017, typically better than Class 1 for the primary classification range ($\pm 0.5\%$ of reading from 20% to 100% of full scale)
- For transducers rated at over 7,000 N·m consult with your Norbar technical sales representative for accuracy statements
- Designed to ignore non-torsional forces
- Smart transducers have a built in memory circuit which contains essential information about the transducer. This information can be read by Norbar's TST, TTT, TTL-HE & T-Box™ 2 instruments meaning that when the transducer is connected, it is immediately recognised and ready for use
- Smart transducers can also be used with many other instruments, however, these will operate as normal ratio calibrated (mV/V) transducers - the Smart data will not be read

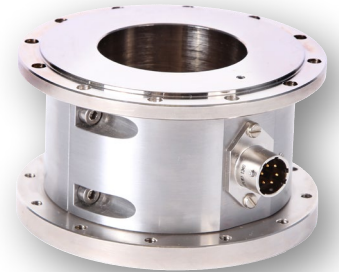

4 ANNULAR TRANSDUCERS FOR STANDARD SERIES GEARBOX

Suitable for PT1, PT1A and PT2

| | |
|-----------|-------------------------------|
| 50638.xxx | 100 - 1,000 N·m ¾" sq. dr. |
| 50648.xxx | 100 - 1,000 lbf-ft ¾" sq. dr. |

Suitable for heavy duty HT2, PT1, PT1A and PT2 (16013.X and 16013.HD)

| | |
|-----------|-------------------------------|
| 50639.xxx | 150 - 1,500 N·m 1" sq. dr. |
| 50649.xxx | 150 - 1,500 lbf-ft 1" sq. dr. |

12

TD2.CCW Alternative calibration direction for transducers up to 1,500 N·m / 1,000 lbf-ft when ordered with new unit

Suitable for HT5 and PT5

| | |
|-----------|-------------------------------|
| 50640.xxx | 250 - 2,500 N·m 1" sq. dr. |
| 50650.xxx | 250 - 2,500 lbf-ft 1" sq. dr. |
| 50641.xxx | 350 - 3,500 N·m 1" sq. dr. |

Suitable for HT6 and PT6

| | |
|-----------|-----------------------------|
| 50700.xxx | 350 - 3,500 N·m 1½" sq. dr. |
|-----------|-----------------------------|

Suitable for HT7 and PT7

| | |
|-----------|--------------------------------|
| 50643.xxx | 500 - 5,000 N·m 1½" sq. dr. |
| 50652.xxx | 500 - 5,000 lbf-ft 1½" sq. dr. |

12

TD5.CCW Alternative calibration direction for transducers from 1,501 - 7,000 N·m / 1,001 - 5,000 lbf-ft when ordered with new unit

4 ANNULAR TRANSDUCERS FOR STANDARD SERIES GEARBOX

Suitable for HT9 and PT9

| | |
|-----------|--------------------------------|
| 50644.xxx | 1,000 - 10,000 N·m 1½" sq. dr. |
| 50653.xxx | 700 - 7,000 lbf-ft 1½" sq. dr. |

Suitable for HT11 and PT11

| | |
|-----------|-----------------------------------|
| 50645.xxx | 2,000 - 20,000 N·m 2½" sq. dr. |
| 50654.xxx | 1,500 - 15,000 lbf-ft 2½" sq. dr. |

Suitable for HT12 and PT12

| | |
|-----------|-----------------------------------|
| 50764.xxx | 3,500 - 35,000 N·m 2½" sq. dr. |
| 50765.xxx | 2,500 - 25,000 lbf-ft 2½" sq. dr. |

Suitable for HT13 and PT13

| | |
|-----------|--------------------------------|
| 50646.xxx | 5,000 - 50,000 N·m 2½" sq. dr. |
|-----------|--------------------------------|

Suitable for PT14

| | |
|-----------|----------------------------------|
| 50647.xxx | 10,000 - 100,000 N·m 3½" sq. dr. |
|-----------|----------------------------------|

12

TD4.CCW Alternative calibration direction for transducers from 7,001 - 100,000 N·m / 5,001 - 75,000 lbf-ft when ordered with new unit

Suitable for PT18.MTS

| | |
|---|----------------------|
| - | 30,000 - 300,000 N·m |
|---|----------------------|

Standard calibration is performed loading counter-clockwise only.

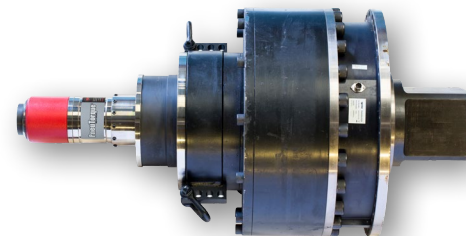
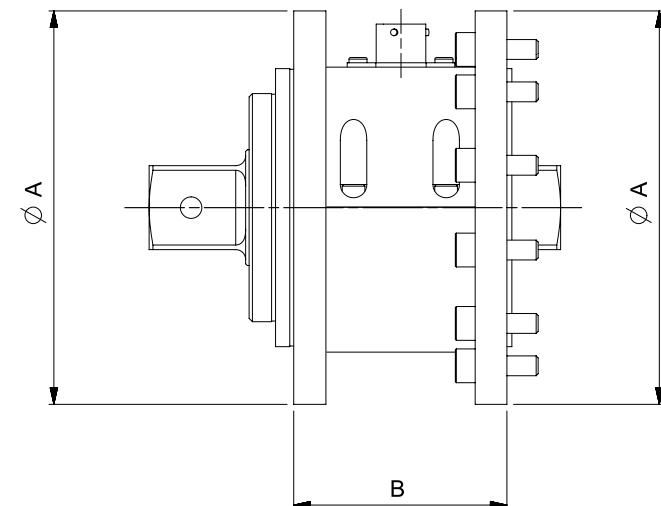

PT 18 fitted with 300,000 N·m Annular Transducer and square drive

| Model | Annular Transducers for use with Standard Series Multipliers | | |
|-----------------|--|--|------------------------|
| Part Number | 50638.xxx 50648.xxx 50639.xxx 50649.xxx | 50640.xxx 50650.xxx 50641.xxx 50700.xxx | 50643.xxx 50652.xxx |
| Dimensions (mm) | ØA | 108 | 144 |
| | B | 60 | 71 |
| Weight (kg) | 1.4 | 2.6 | 3.6 |



ANNULAR TRANSDUCERS

Calibration details



4 TORQUE & ANGLE ANNULAR TRANSDUCERS - FIXED CONNECTOR

Suitable for heavy duty PT1, PT1A and PT2

50820.LOGA* 100 - 1,000 N·m ¾" sq. dr.

50821.LOGA** 150 - 1,500 N·m 1" sq. dr.

* Can only be used with remote/plain sleeve motors i.e. not a standard PT handle, due to cable interference.

* Only fits to PT with HD final stage carrier having 1" female sq. dr.

Suitable for HT5 and PT5

50822.LOGA 350 - 3,500 N·m 1" sq. dr.

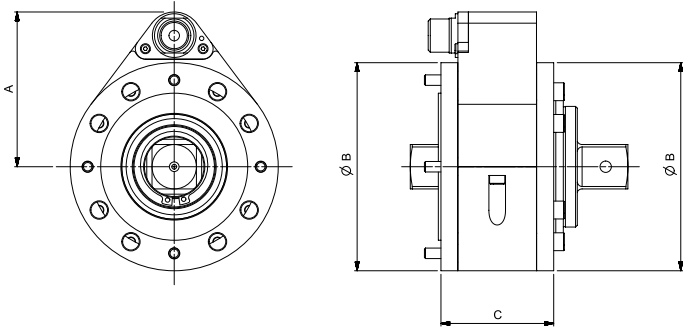

| Model | | Torque & Angle Annular Transducers with Fixed Connector |
|-----------------|----|---|
| Part Number | | 50820.LOGA 50821.LOGA 50822.LOGA |
| Dimensions (mm) | A | 89 |
| | ØB | 119 |
| | C | 65 |
| Weight (kg) | | 1.4 |



Fixed Connector

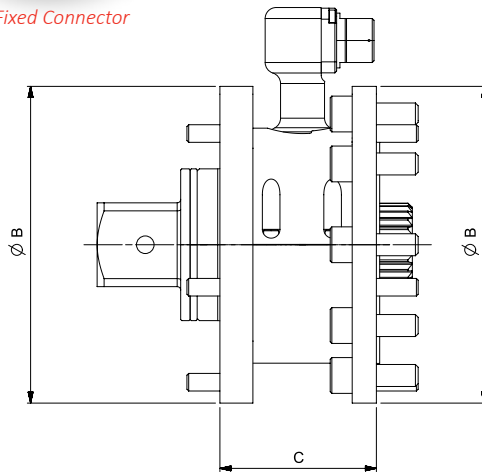
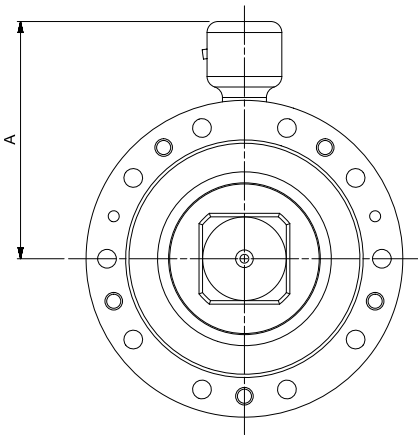

180° Swivel Connector

4 TORQUE & ANGLE ANNULAR TRANSDUCERS - 180° SWIVEL CONNECTOR

Suitable for HT7 and PT7

50834.LOGA 500 - 5,000 N·m 1½" sq. dr.

Suitable for HT9 and PT9

50824.LOGA 1,000 - 10,000 N·m 1½" sq. dr.

Suitable for HT11 and PT11

50825.LOGA 2,000 - 20,000 N·m 2½" sq. dr.

Suitable for HT12 and PT12

50826.LOGA 3,500 - 35,000 N·m 2½" sq. dr.

Suitable for HT13 and PT13

50827.LOGA 5,000 - 50,000 N·m 2½" sq. dr.

Suitable for HT14 and PT14

50828.LOGA 10,000 - 100,000 N·m 3½" sq. dr.

PT13 & PT14 require special front cover plate with added dowel clearance holes

Suitable for HT15 and PT15

50832.LOGA 15,000 - 150,000 N·m 4½" sq. dr.

Suitable for HT16 and PT16

50829.LOGA 20,000 - 200,000 N·m 5" sq. dr.

Suitable for HT17 and PT17

50830.LOGA 25,000 - 250,000 N·m 6" sq. dr.

Suitable for HT18 and PT18

50831.LOGA 30,000 - 300,000 N·m 6" sq. dr.

| Model | Torque & Angle Annular Transducers with Swivel Connector | | | | | | | | | | |
|-----------------|--|------------|------------|------------|------------|-------------|-------------|-------------|-------------|-------------|-----|
| | 5,000 N·m | 10,000 N·m | 20,000 N·m | 35,000 N·m | 50,000 N·m | 100,000 N·m | 150,000 N·m | 200,000 N·m | 250,000 N·m | 300,000 N·m | |
| Part Number | 50834.LOGA | 50824.LOGA | 50825.LOGA | 50826.LOGA | 50827.LOGA | 50828.LOGA | 50832.LOGA | 50829.LOGA | 50830.LOGA | 50831.LOGA | |
| Dimensions (mm) | A | 108 | 120 | 140 | 151 | 186 | 186 | * | * | * | 289 |
| | ØB | 144 | 178 | 212 | 248 | 315 | 315 | * | * | * | 520 |
| | C | 144 | 184 | 212 | 240 | 315 | 315 | * | * | * | 520 |
| Weight (kg) | 7.0 | 10.0 | 15.0 | 29.3 | 43.5 | 46.6 | * | * | * | 149.5 | |

* Available on request



FLANGE MOUNTED TRANSDUCERS (FMT)



Calibration details



Flange Mounted Transducers (FMT) incorporate mounting points for securely fixing the transducer to the working surface. The transducer lead which comes attached to the transducer, is fitted with a high quality connector, suitable for attachment to TST, TTT and T-Box™ 2 instruments. FMTs are provided with precision square drive adaptors suitable for the calibration of torque wrenches.



FMT 2 N-m

| Model | FMT (2 N-m - 25 N-m) | FMT (60 N-m - 400 N-m) | FMT (1,500 N-m) | |
|-----------------|---------------------------|------------------------------------|--|----------------------------------|
| Part Number | 50671.xxx | 50844.xxx | 50676.xxx | |
| | 50672.xxx | 50674.xxx | 50680.xxx | |
| | 50673.xxx | 50675.xxx | 50681.xxx | |
| | 50677.xxx | | | |
| | 50678.xxx | | | |
| | 50679.xxx | | | |
| Dimensions (mm) | ØA | 5.5 | 8.5 | 12 |
| | ØB | 64 | 90 | 150 |
| | C | 63 | 65 | 84 |
| | D | 83 (1/4"), 86 (3/8") | 92 (1/4"), 95 (3/8"), 101 (1/2"), 108 (3/4") | 128 (1/2"), 138 (3/4"), 138 (1") |
| | E | 132 | 192 (60 N-m, 150 N-m & 100 lbf-ft) N/A (400 N-m & 250 lbf-ft) | N/A |
| Weight (kg) | 0.8 (2 N-m & 20 lbf-in) | 1.6 (60 N-m, 150 N-m & 100 lbf-ft) | 7.0 | |
| | 0.8 (10 N-m & 100 lbf-in) | 1.7 (400 N-m) | | |
| | 0.9 (25 N-m & 250 lbf-in) | 2.7 (250 lbf-ft) | | |

| 4 | FMT |
|------------|---|
| 50671.xxx* | 0.04 - 2 N-m, 1/4" sq. dr. with Joint Simulator |
| 50672.xxx | 0.5 - 10 N-m, 1/4" sq. dr. with Joint Simulator |
| 50673.xxx | 1.25 - 25 N-m, 1/4" + 3/8" sq. dr. with Joint Simulator |
| 50677.xxx* | 0.4 - 20 lbf-in, 1/4" sq. dr. with Joint Simulator |
| 50678.xxx | 5 - 100 lbf-in, 1/4" sq. dr. with Joint Simulator |
| 50679.xxx | 12.5 - 250 lbf-in, 1/4" + 3/8" sq. dr. with Joint Simulator |



FMT 150 N-m

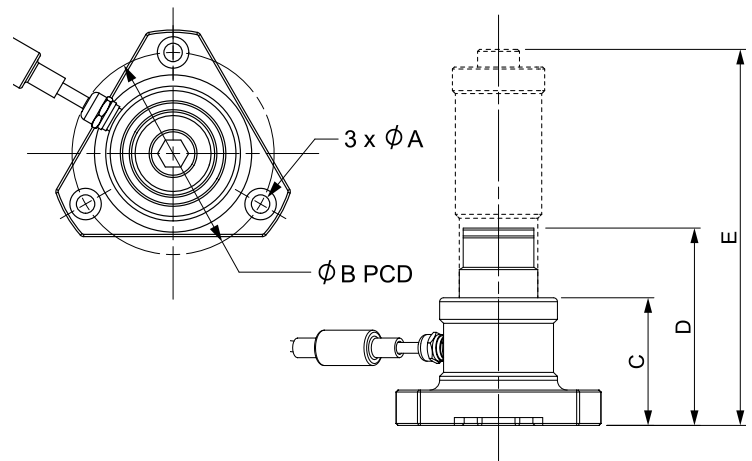

| 4 | FMT |
|-----------|--|
| 50844.xxx | 3 - 60 N-m, 1/2" + 3/8" sq. dr. with Joint Simulator |
| 50674.xxx | 7.5 - 150 N-m, 1/2" + 3/8" sq. dr. with Joint Simulator |
| 50680.xxx | 5 - 100 lbf-ft, 1/2" + 3/8" sq. dr. with Joint Simulator |
| 50675.xxx | 20 - 400 N-m, 1/2" + 3/4" sq. dr. |
| 50681.xxx | 12.5 - 250 lbf-ft, 1/2" + 3/4" sq. dr. |



| 4 | FMT (Ancillary Section) |
|-------|---|
| 50539 | 3 N-m Joint Simulator (also fits TST & TruCheck 2) |
| 50540 | 10 N-m Joint Simulator (also fits TST & TruCheck 2) |
| 50541 | 25 N-m Joint Simulator (also fits TST) |
| 50852 | 30 N-m Joint Simulator (also fits TruCheck 2) |
| 50845 | 60 N-m Joint Simulator |
| 50692 | 150 N-m Joint Simulator |
| 50819 | 400 N-m Joint Simulator |
| 52236 | 1/4" Hexagon - 1/4" Square Drive Adaptor |
| 52237 | 1/4" Hexagon - 3/8" Square Drive Adaptor |
| 52251 | 3/8" Female Square - 22 mm Bi-Square Adaptor |
| 52246 | 1/2" Female Square - 22 mm Bi-Square Adaptor |
| 52245 | 3/4" Female Square - 22 mm Bi-Square Adaptor |
| 52254 | 1/2" Female Square - 35 mm Bi-Square Adaptor |
| 52241 | 3/4" Female Square - 35 mm Bi-Square Adaptor |
| 52242 | 1" Female Square - 35 mm Bi-Square Adaptor |

| 4 | FMT Mounting Brackets |
|---------------|--------------------------------------|
| 62221.BLK9005 | FMT Mounting Bracket 2 - 400 N-m |
| 62220.BLK9005 | FMT Mounting Bracket 150 - 1,500 N-m |



FLANGE MOUNTED TRANSDUCERS (FMT)

Calibration details



| | |
|-----------|--|
| 4 | FMT |
| 50676.xxx | 30 - 1,500 N·m, 1/2", 3/4" + 1" sq. dr. |
| 50682.xxx | 20 - 1,000 lbf·ft, 1/2", 3/4" + 1" sq. dr. |

| | |
|---------|--|
| 12 | |
| TD1.CCW | Counter-clockwise calibration for FMT & STB when ordered with new unit |

xxx Indicates .LOG or .IND versions, please see page 89.
 * If using this transducer with a Series 1 TST or TTT (Part No.s 43198 - 43201) or a Pro-Log Display instrument, please contact Norbar.

Includes integral transducer lead with connector to suit TST, TTT and T-Box™ 2. Additional lengths can be accommodated, consult Norbar for details.



FMT 1,500 N·m

ISO 3000 LOADER

These loaders allow torque wrenches to be tested or calibrated to relevant ISO standards when used in an appropriate temperature controlled environment. Their function is to take full advantage of the accuracy of Norbar's torque measuring system by reducing operator induced variations in the calibration process.

- The high ratio, 1250:1 gearbox allows high torques to be applied with minimal effort
- Used with a T-Box™ 2 instrument, the timer feature will allow the rate of torque application to meet the requirement of ISO6789:2017
- The design allows for easy interchange of transducers using the Norbar Static Transducer system
- Floating reaction point minimises side loads on the wrench. It is a requirement of ISO6789:2017 that parasitic forces on the wrench under test are minimised
- Reaction extension bar allows wrenches up to 2,200 mm to be tested. This can be removed to save space. Wrenches up to 1,100 mm can be tested when the extension bar is not fitted

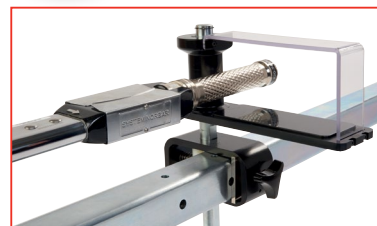
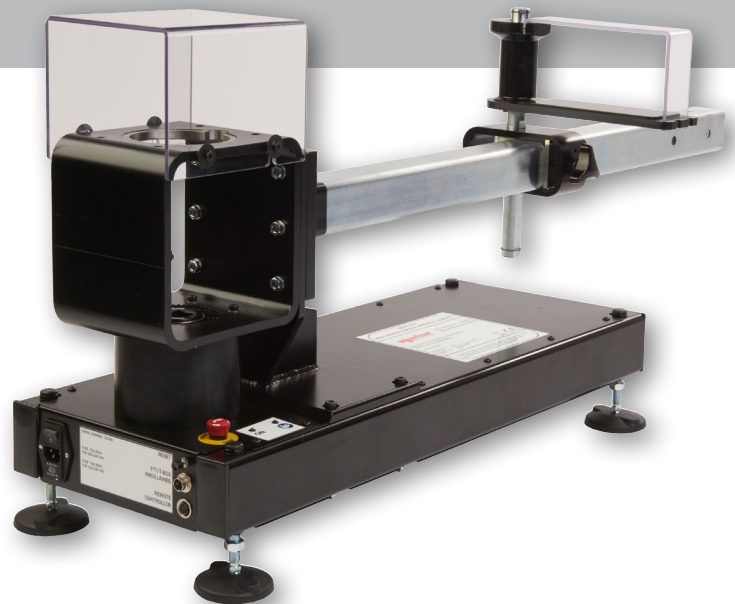

| | |
|-------|--------------------------------------|
| 4 | TORQUE WRENCH LOADERS |
| 20505 | Loader, ISO 3,000 N·m |
| 20506 | Motorised ISO 3,000 N·m |
| 20606 | Short Length Reaction Plate Assembly |

| Model | ISO 3000 N·m | Motorised ISO 3000 N·m |
|-----------------|--------------|------------------------|
| Part Number | 20505 | 20506 |
| Dimensions (mm) | A | 451 |
| | B | 2,440 |
| | C | 1,232 |
| | D | 534 |
| Weight (kg) | 55.0 | 40.0 |

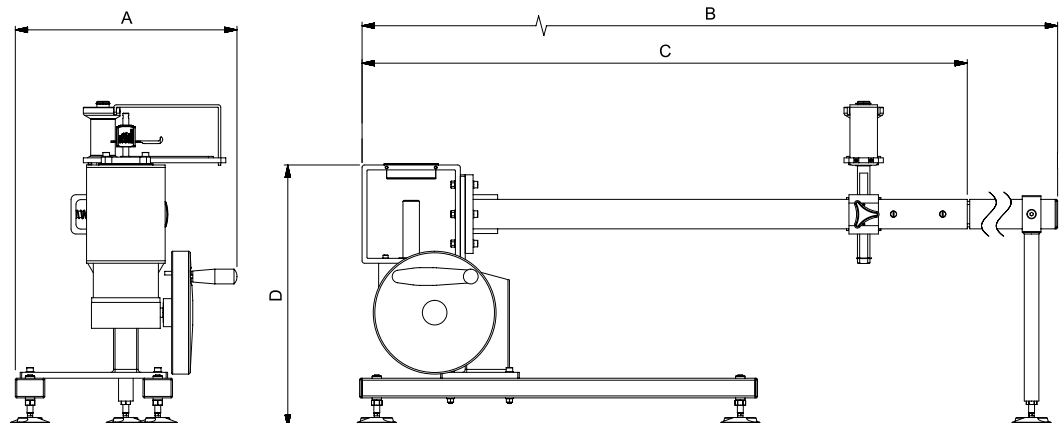



TORQUE WRENCH CALIBRATOR - MANUAL



Torque Wrench Calibrator (TWC) 400 N-m Manual

- Enables torque wrench calibration or testing in accordance with ISO 6789-2:2017 if used with T-Box™ 2
- Also in accordance with BS EN 26789:2003, ISO 6789-1:2017
- Counterbalance Reaction system is designed to support the weight of the wrench so that the weight does not become a parasitic force within the calibration system. The floating nature of the support means that the wrench is able to find its own natural level rather than being constrained as in many other loading devices. Any such constraint will be a parasitic force within the system (Patents apply)
- Lightweight alloy construction ensures the TWC is easily transported, making it well suited for mobile laboratory applications
- Two speed gearbox designed for a sufficient balance of speed and control by allowing for both fast loading of the torque wrench and a slower more precise loading
- Works with Flange Mounted Transducers, Static Transducers (when using part number: 60318), T-Box™ 2, TST, TTT and Pro-Test (when using part number: 60323)
- During calibration the TWC maintains a fixed position on the handle of the torque wrench
- Rotating transducer design ensures that the load is applied 90° to the torque wrench handle. The benefit of this precise alignment is that forces are applied squarely to the load point of the handle
- When testing for conformity or calibrating to ISO6789:2017 any transducer must not be used below 5% of its capacity when used with TWC. This statement does not apply to a TWC when used in a accredited laboratory

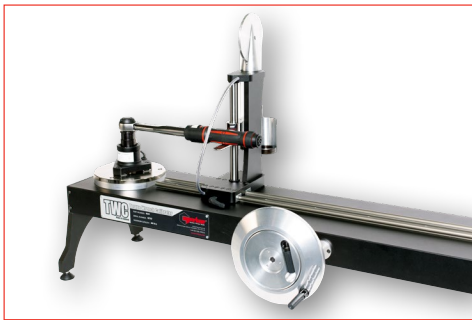

Torque Wrench Calibrator (TWC) Manual shown with a Flange Mounted Transducer and a Model 100 torque wrench (not included)

| 4 TORQUE WRENCH CALIBRATOR (TWC) | |
|----------------------------------|---|
| 60331 | Torque Wrench Calibrator 400 N-m Manual |
| 60332 | Torque Wrench Calibrator 1,500 N-m Manual |

| Model | | TWC 400 | TWC 1500 |
|-------------------------------|-----|---------|----------|
| Part Number | | 60331 | 60332 |
| Wrench Length (Torque Radius) | Min | 135 | 135 |
| | Max | 750 | 1,500 |
| Dimensions (mm) | A | 620 | 620 |
| | B | 330 | 330 |
| | C | 395 | 395 |
| | D | 487 | 487 |
| | E | 1,010 | 1,760 |
| Weight (kg) | | 35.0 | 40.0 |

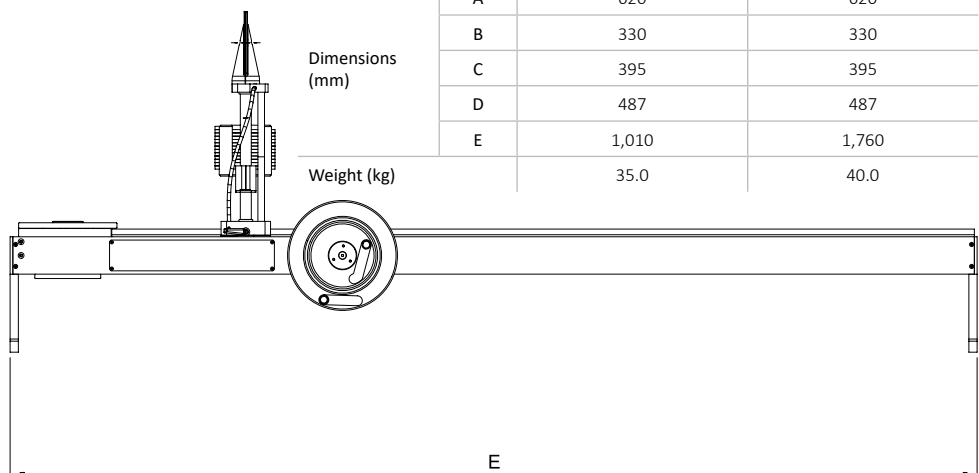
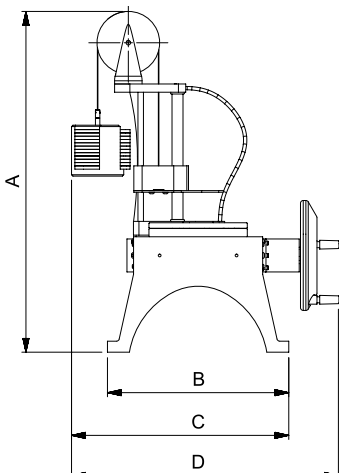

Patented in the UK, Germany, France and Italy (EP2864745) and in the USA (US9921122).



TORQUE WRENCH CALIBRATOR - ANCILLARIES

There are a wide range of accessories available for the TWC that will allow the user greater flexibility.

- 60322 Quick Release Kit allows for a more streamlined and efficient calibration laboratory
- 60324 Hexagon Adaptor Kit for use with the TWC Manual allows users to speed up the workflow by implementing their own solution to rapidly manoeuvre the wrench up to the reaction point
- 60330 Offset Angle Plate Kit allows for greater flexibility when calibrating fixed head torque wrenches

| 8 | TWC ANCILLARIES |
|--------|---|
| 60318 | Static Transducer Support Kit |
| 60319 | Short Length Reaction Post |
| 60322* | Quick Release FMT Kit |
| 60323 | Pro-Test and Static Torque Block Adaptor Kit |
| 60324 | Hexagon Adaptor Kit |
| 60325 | TWC Greasing Kit |
| 60326 | TWC Bench Mounting Kit |
| 60327* | FMT 2 to FMT 25 Adaptor Kit |
| 60329 | 3 kg Mass Weight |
| 60330 | Offset Angle Plate Kit |
| 62352 | TWC CBR Cable |
| 29214 | 1" Male to 3/4" Female Flanged Square Drive Adaptor |
| 29215 | 1" Male to 1/2" Female Flanged Square Drive Adaptor |
| 29216 | 1" Male to 3/8" Female Flanged Square Drive Adaptor |
| 29217 | 1" Male to 1/4" Female Flanged Square Drive Adaptor |

* Kit contains two Quick Release FMT plates
 + 60327 is essential for users of FMTs that are 25 N-m/250 lbf-in and smaller



60322 Quick Release FMT Kit



60330 Offset Angle Plate Kit



60318 Static Transducer Support Kit and 60319 Short Length Reaction Post



60318



60319



29214 Flanged Square Drive Adaptor



60329 3 kg Mass Weight



60327 FMT 2 to FMT 25 Adaptor Kit



TORQUE WRENCH CALIBRATOR - AUTO



Calibration details



For a complete torque wrench calibration system, just add the transducer range appropriate for the wrenches you wish to calibrate and accessories from page 99.

- Enables torque wrench calibration or testing in accordance with ISO 6789:2017 Part 1 and 2
- Counterbalance Reaction system is designed to support the weight of the wrench so that the weight does not become a parasitic force within the calibration system. The floating nature of the support means that the wrench is able to find its own natural level rather than being constrained as in many other loading devices. Any such constraint will be a parasitic force within the system (Patents apply)
- Lightweight alloy construction ensures the TWC is easily transported, making it well suited for mobile laboratory applications
- Works with Flange Mounted Transducers and Static Transducers
- During calibration, the TWC maintains a fixed position on the handle of the torque wrench
- Rotating transducer design ensures that the load is applied 90° to the torque wrench handle. The benefit of this precise alignment is that forces are applied squarely to the load point of the handle
- Supplied with a powerful yet simple touchscreen User Interface (UI) (keyboard and mouse also supported if desired)
- Flexible tool template system; minimises number of templates required to cover a wide range of tools, aiding efficient use
- Programmable calibration workflow for each template, can be pre-set to ISO compliant flow for the given tool for a faster set-up or can also support bespoke workflows

- Calibration job management; book calibrations, track progress of previous bookings and resume them
- Automated management of calibration and conformance workflows for non-indicating tools
- Intelligent rate control system ensures fast cycling of tools while maintaining compliance with 2017 standards
- Environmental monitoring (humidity/temperature) to assist compliance with calibration standards
- Automated management of uncertainty data for ISO 6789-2:2017 calibrations, guiding the user through the process using dynamically generated instructions based on the current tool's ISO classification and workflow
- Inbuilt data analysis and certification generation seamlessly move from calibration/conformance procedure to certificate generation, no third-party software required
- A substantial amount of inbuilt storage allowing for several years' worth of calibration data through normal use
- The TWC control Box is supported by a UKAS accredited certificate of calibration, we remain one of the few manufacturers in the world that issue a UKAS accredited calibration certificate both for the instrument and for the torque transducer. In doing so, customers can swap combinations of instrument and transducer while retaining complete traceability
- When testing for conformity or calibrating to ISO6789:2017 any transducer must not be used below 5% of its capacity when used with TWC. This statement does not apply to a TWC when used in a accredited laboratory



| 5 | TORQUE WRENCH CALIBRATOR (TWC) |
|-------|---|
| 60312 | Torque Wrench Calibrator 400 N·m Auto |
| 60313 | Torque Wrench Calibrator 1,500 N·m Auto |



Torque Wrench Calibrator (TWC) Auto shown with a Professional Model 200 and a Static Transducer with support kit (not included)



TORQUE WRENCH CALIBRATOR - AUTO



Software Screen Shots:



Main menu

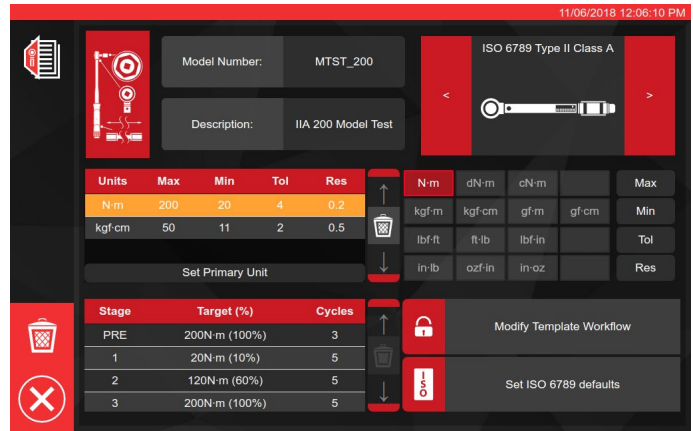

Tool template editor

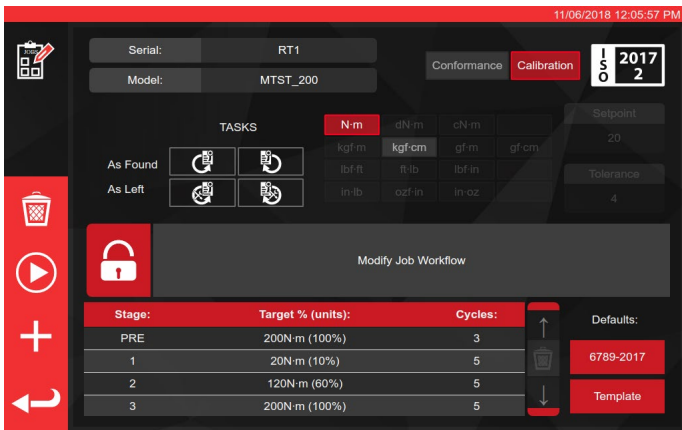

Calibration job booking / editor

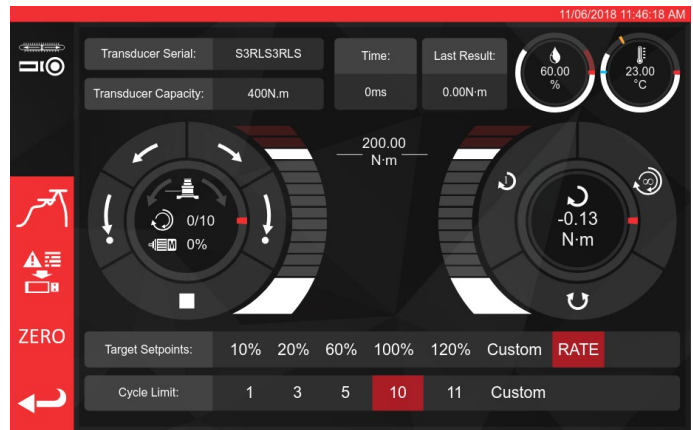

Tool cycling and adjustment

| Model | TWC Auto 400 | TWC Auto 1500 |
|-------------------------------|--------------|---------------|
| Part Number | 60312 | 60313 |
| Wrench Length (Torque Radius) | Min | 135 |
| | Max | 750 |
| Dimensions (mm) | A | 620 |
| | B | 330 |
| | C | 395 |
| | D | 1,019 |
| Weight (kg) | 40.0 | 45.0 |

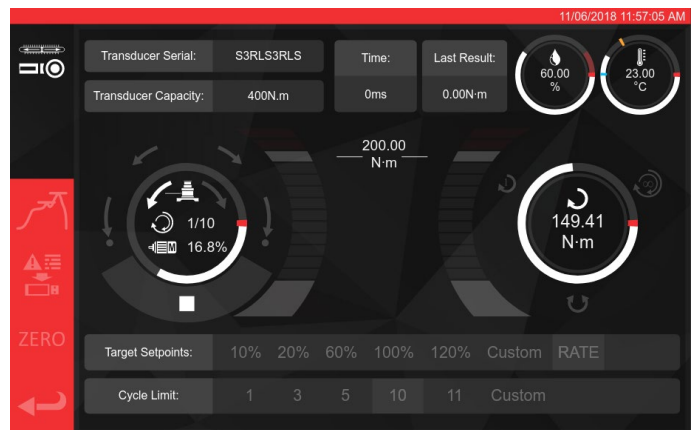

Tool cycling and adjustment whilst in operation

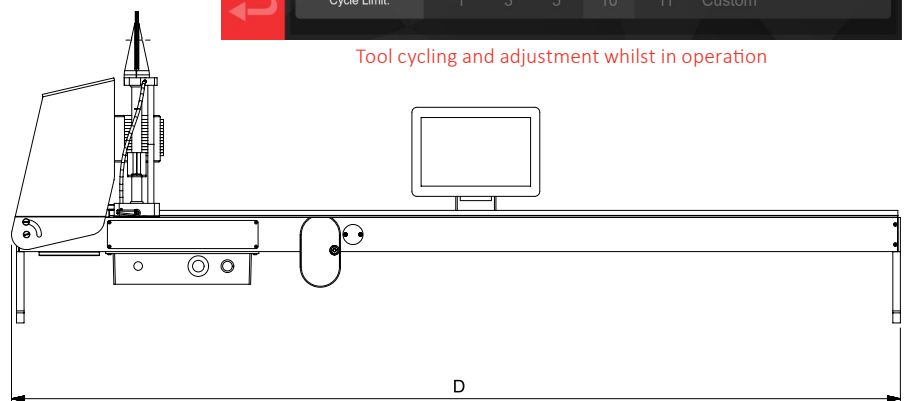
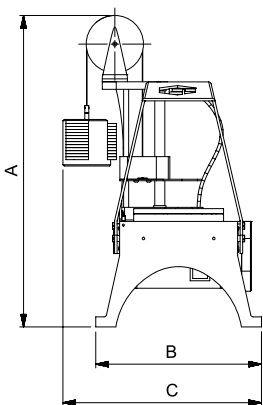

Patented in the UK, Germany, France and Italy (EP2864745) and in the USA (US9921122).



TEST RIGS AND FIXTURES

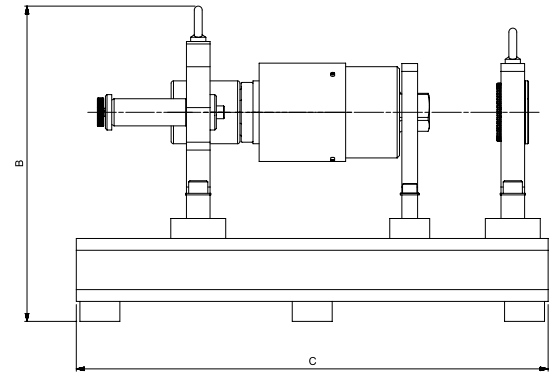
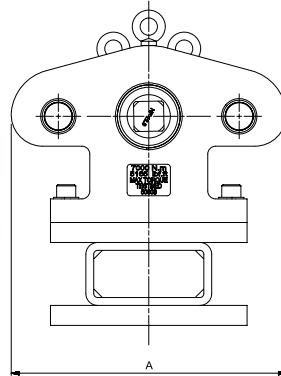
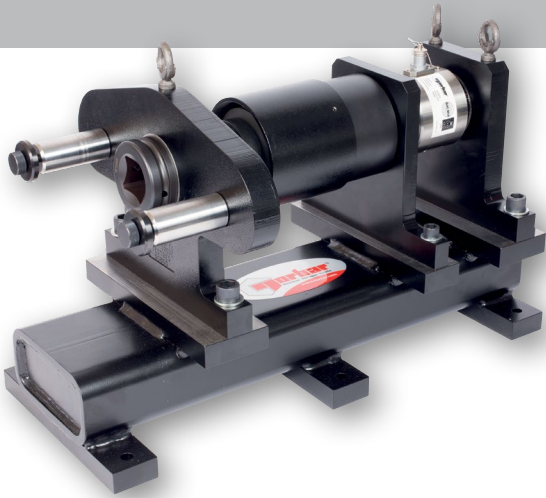

Power Tool Test Rig shown with 1½" M/F Static Transducer (not included)

| 4 | ET/EBT/PT POWER TOOL TEST RIG |
|-------|--|
| 50800 | 7,000 N·m ET, EBT, PT Power Tool Test Rig (supplied with the 8 reaction plates on page 104 (excluding blank reaction plate) and ¾", 1" and 1½" sq. dr. adaptors) |
| 50803 | 7,000 N·m ET, EBT, PT Power Tool Test Rig without Reaction Plates (supplied with ¾", 1" and 1½" sq. dr. adaptors) |

Note: The static transducer 50669.LOG does not come supplied as standard with the tool test rig. The standard range of 700 - 7,000 N·m will not cover the full powered multiplier range, additional calibration may be required, please see below:

| 12 | ADDCALPOINTS.NEW |
|----|--|
| | Additional calibration steps below 10% of rated capacity to 2% for transducers up to 7,000 N·m (5,000 lbf·ft) when ordered with new unit |

| Model | Power Tool Test Rig |
|-----------------|---------------------|
| Part Number | 50800 50803 |
| Dimensions (mm) | A 350 |
| | B 401 |
| | C 600 |
| Weight (kg) | TBC |

The Angle Test Fixture calibration hub can be used when re-calibrating the Angle feature of your torque wrench.

This fixture has pre-determined angle increments that enable the user to set and verify the Angle output of their wrench making corrections where required.

| 9 | ANGLE TEST FIXTURE |
|-------|--------------------|
| 60351 | Angle Test Fixture |



The Norbar Joint Simulation Rundown Assemblies are designed to simulate the working conditions of screwed or bolted joints. Used in conjunction with a Norbar transducer and display instrument, the output of torque controlled power tools can be measured against a range of simulated joint rates, from hard through to soft.

| 4 | JOINT SIMULATION RUNDOWN ASSEMBLIES |
|--------|-------------------------------------|
| 50313 | 0.2 - 2 N·m (2 - 20 lbf·in) |
| 50251 | 2 - 10 N·m (20 - 100 lbf·in) |
| 50252 | 5 - 50 N·m (5 - 50 lbf·ft) |
| 50253 | 10 - 100 N·m (10 - 100 lbf·ft) |
| 50254* | 100 - 500 N·m (100 - 500 lbf·ft) |

The above are for use with Norbar static square to square transducers and bench stands, see page 89 & page 90.

* To be used with large frame size bench stands, all others to be used with small frame bench stands.

NOTE: Spare washer stacks are available for use with Joint Simulation Rundown Assemblies, contact Norbar

| | |
|-------|---------------------------------|
| 50693 | 10 - 140 N·m (10 - 100 lbf·ft) |
| 50694 | 100 - 700 N·m (70 - 500 lbf·ft) |

The above are for use with the Norbar Smart Torque Block (STB) 1000.



TEST RIGS AND FIXTURES

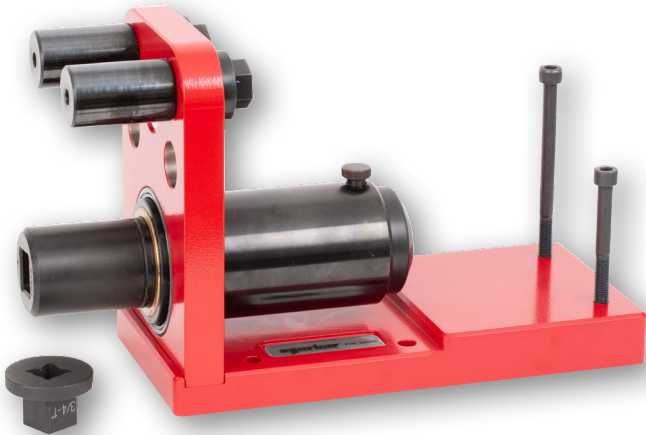

| Model | Power Tool Test Fixture for TruCheck 2 |
|-------------|--|
| Part Number | 80033 |
| F | 51 |
| G | 152 |
| H | 229 |
| J | 75 |
| K | 125 |
| L | 77 |
| M | 86 |
| N | 76 |
| P | 6 |
| Q | 318 |
| Weight (kg) | 24.5 |

The Power Tool Test Fixture for TruCheck™ 2 is a simple, robust device that allows non-impacting power tools up to 2,100 N·m to be tested. A system comprises the Test Fixture with a TruCheck™ 2 Plus (to be ordered separately), either the 1,100 N·m or 2,100 N·m models, depending on the torque capacity required. The universal torque reaction arrangement will suit reaction arms supplied as standard with most Norbar and other pneumatic, electric and cordless torque tools.

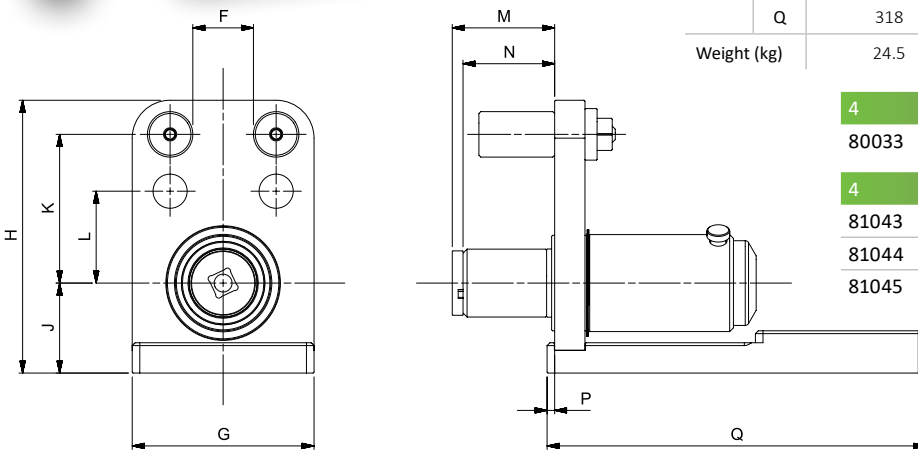

| | |
|-------|---|
| 4 | POWER TOOL TEST FIXTURE FOR TRUCHECK 2 |
| 80033 | Power Tool Test Fixture for use with TruCheck 2 |
| 4 | 80033 SPARE PARTS |
| 81043 | Spacer Sleeve |
| 81044 | Bellville Washer Stack (pack of 8 washers) |
| 81045 | Replacement Rundown Screw & Nut |

NOTE: This test Fixture is not suitable for TruCheck™ version 1.

For tools with continuous rotation it is recommended they are tested on a rig with a simulated joint.

Norbar test fixtures use custom machined rundown elements for extended life and smooth operation.

NOTE: The test fixture needs to be connected to an appropriate Norbar instrument. Transducer not included. Transducer lead (for use with Norbar Static and Annular transducers) included.

| | |
|-------|---|
| 4 | POWER TOOL TEST FIXTURE |
| 80036 | Power Tool Test Fixture and Annular Transducer Kit (up to 8,100 N·m/6,000 lbf·ft) |

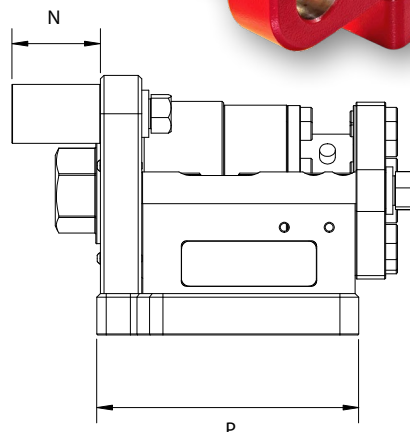
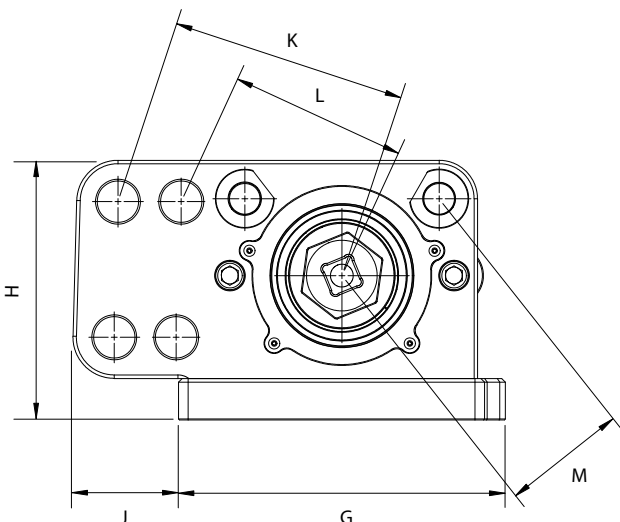

| Model | Power Tool Test Fixture |
|-------------|-------------------------|
| Part Number | 80036 |
| G | 277 |
| H | 220 |
| J | 90 |
| K | 200 |
| L | 150 |
| M | 105 |
| N | 75 |
| P | 206 |
| Weight (kg) | TBC |



TEST RIGS AND FIXTURES



Universal Tool Test Rig (1½" M/F Static Transducer required (not included))



Power Tool Test Rig with Reaction Plates (50800)

| 4 7,000 N-m UNIVERSAL TOOL TEST RIGS | |
|--------------------------------------|--|
| 50801 | Universal 7,000 N-m ET, EBT, PT & Hydraulic Tool Test Rig (supplied with the 8 reaction plates (excluding blank reaction plate) and ¾", 1" and 1½" sq. dr. adaptors) |
| 50804 | Universal 7,000 N-m Test Rig without Reaction Plates (supplied with ¾", 1" and 1½" sq. dr. adaptors) |

| 4 SPARES FOR 50800, 50801, 50803 & 50804 | |
|--|--------------------------|
| 50800.29 | 2" AF Socket 1½" sq. dr. |
| 50800.28 | 2" AF Socket 1" sq. dr. |
| 50800.27 | 2" AF Socket ¾" sq. dr. |

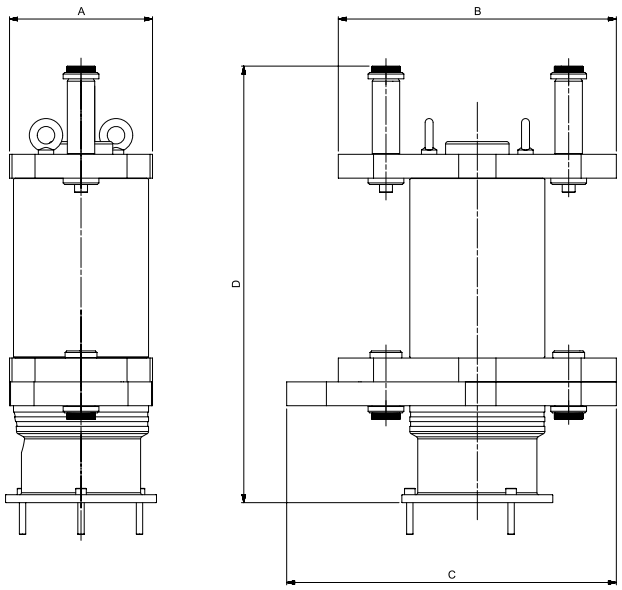

| Model | Universal Tool Test Rig | |
|-----------------|-------------------------|-----|
| Part Number | 50801, 50804 | |
| Dimensions (mm) | A | 180 |
| | B | 350 |
| | C | 415 |
| | D | 550 |
| Weight (kg) | 73.0 | |

See pages page 106 & page 107 for accessories for use with Hydraulic Tool Calibration Fixture

NOTE: Reaction plate dimensions can be found by searching their part number on the Norbar website

| | |
|---------|---|
| 81041 | Nut and bolt set for 7,000 N-m Power Tool Test Rigs |
| 50548.4 | Washer Stack Kit 100 - 7,000 N-m (Also for use with RD5000) |

Universal Hydraulic Tool Test Rig with Reaction Plates (50801)



| 4 REACTION PLATES FOR USE WITH 50803 & 50804 | |
|--|--|
| 81024 | Suitable for ET/EBT/PTS/PTM 119, PT 4500 and PT 5500 |
| 81025 | Suitable for ET/EBT/PTS/PTM 92 |
| 81026 | Suitable for ET/EBT/PTS/PTM 72 |
| 81027 | Suitable for PTS/PTM 52 |
| 81028 | Suitable for PT 2700 |
| 81030 | Suitable for PT 5 and PT 6 |
| 81031 | Suitable for PT 7 |
| 81032 | Blank Reaction Plate for Universal Test Rigs |

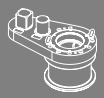

HYDRAULIC TOOL CALIBRATION FIXTURES

Hydraulic Tool Calibration Fixtures 106
Hydraulic Tool Calibration Accessories 107
Hexagon to Square Adaptors 108

Norbar's Hydraulic Tool Calibration Fixture is a robust device that allows accurate testing of hydraulic torque wrenches. A system comprises of a Calibration Fixture and Transducer, also required is a torque measuring instrument and transducer cable.

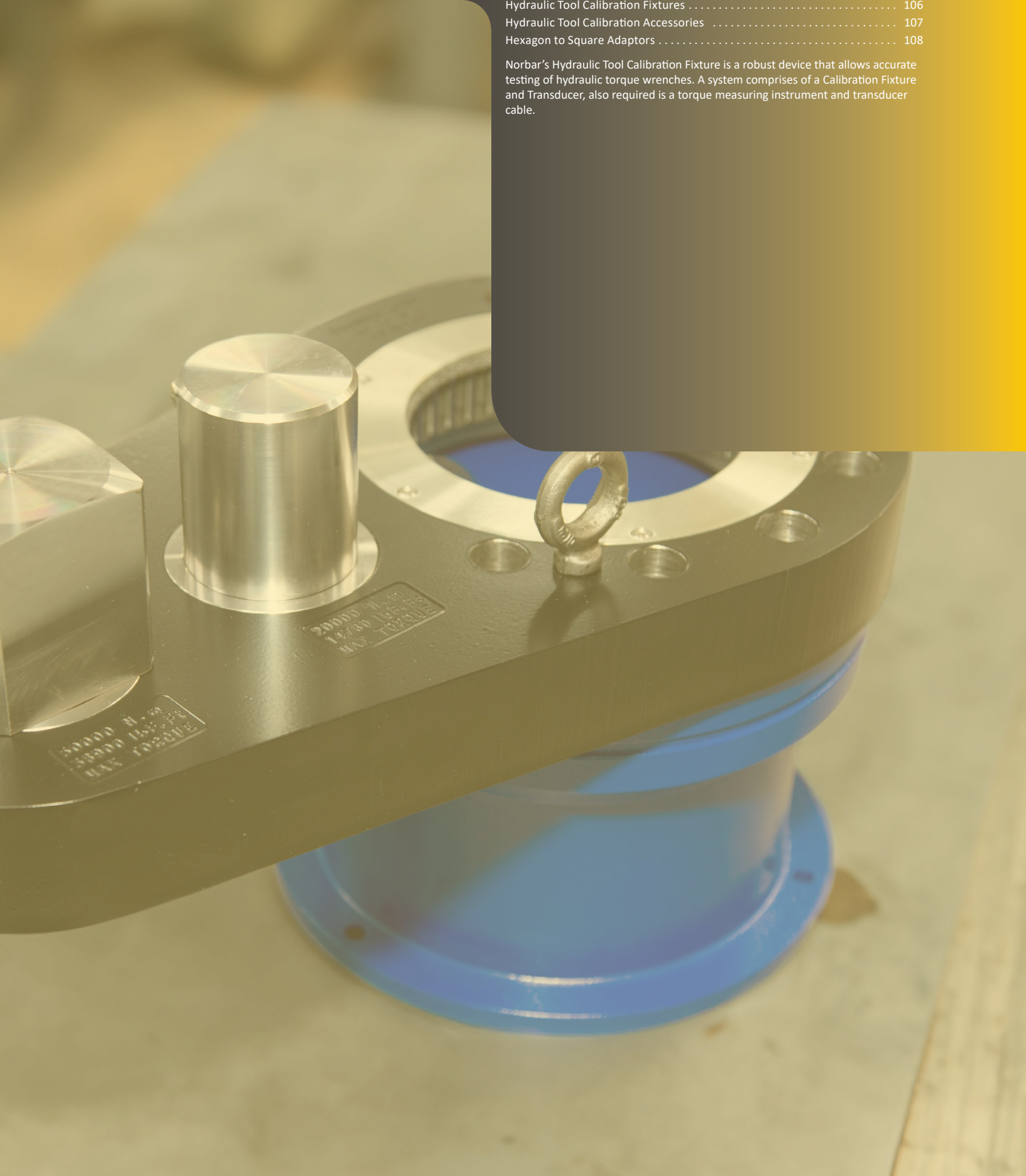



HYDRAULIC TOOL CALIBRATION FIXTURES



| 4 | CALIBRATION FIXTURES |
|-------|--|
| 80031 | Hydraulic Calibration Fixture up to 7,000 N-m |
| 80029 | Hydraulic Calibration Fixture up to 50,000 N-m |
| 80032 | Hydraulic Calibration Fixture up to 80,000 N-m |
| 81022 | Reaction Bar for 80031 |
| 81023 | Reaction Bar for 80029 |

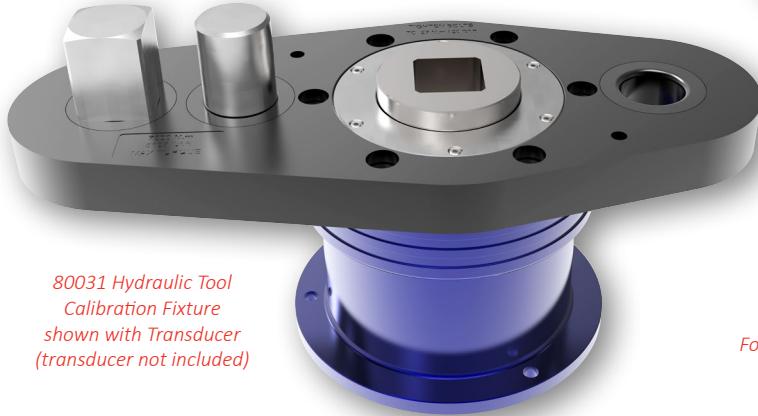

80031 Hydraulic Tool Calibration Fixture shown with Transducer (transducer not included)



For more information regards Hydraulic Torque Wrenches please contact Norbar

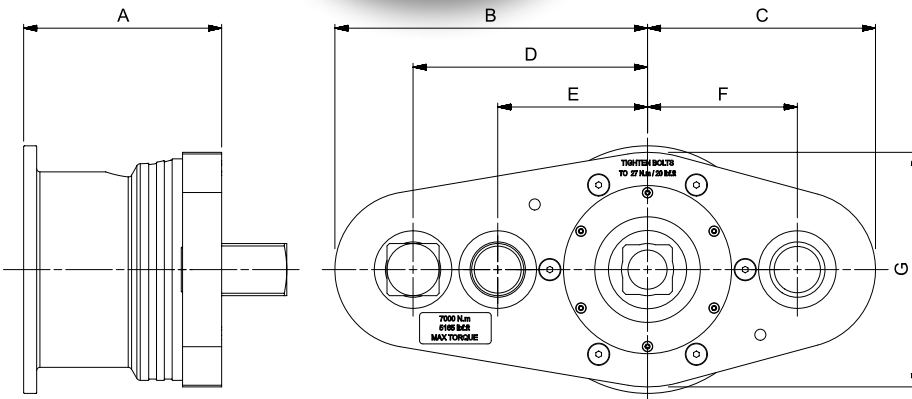

| Model | Hydraulic Calibration Fixture up to 7,000 N-m | Hydraulic Calibration Fixture up to 50,000 N-m | Hydraulic Calibration Fixture up to 80,000 N-m |
|-----------------|---|--|--|
| Part Number | 80031 | 80029 | 80032 |
| Dimensions (mm) | A | 202 | 208 |
| | B | 240 | 325 |
| | C | 175 | 125 |
| | D | 180 | 250 |
| | E | 115 | 150 |
| | F | 115 | N/A |
| | G | 180 | 250 |
| Weight (kg) | TBC | TBC | TBC |

| 4 | DUAL CALIBRATION FIXTURE |
|-------|--------------------------|
| 80030 | Dual Calibration Fixture |

Note: Houses 1 transducer up to 7,000 N-m and 1 transducer up to 50,000 N-m in a bench top plate.



Dual Calibration Fixture (Part No. 80030)

| Model | Dual Calibration Fixture | |
|-----------------|--------------------------|-----|
| Part Number | 80030 | |
| Dimensions (mm) | A | 710 |
| | B | 193 |
| | C | 250 |
| | D | 142 |
| | E | 150 |
| | F | 380 |
| | G | 105 |
| Weight (kg) | 140.0 | |

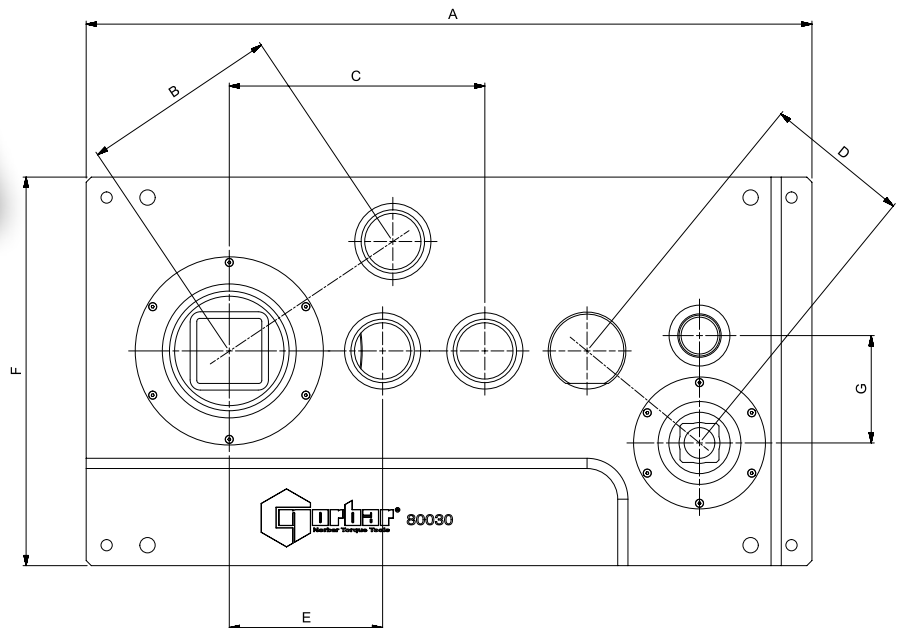

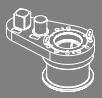

HYDRAULIC TOOL CALIBRATION ACCESSORIES

Rapid hydraulic wrench calibrations (for instance, from many minutes to around one minute) are possible using appropriate hydraulic calibration fixtures and accessories along with the T-Box™ 2. The T-Box™ 2 can take simultaneous hydraulic pressure readings and torque readings at pre-configured trigger points. By ramping up the hydraulic pressure from the minimum to the maximum for the torque wrench under test, pressure and torque readings will be taken and recorded at the required points. This data can be saved to Excel and exported to appropriate third-party calibration certification software.

This feature is not limited to hydraulic torque wrench calibration. By substituting the hydraulic pressure transducer for a pneumatic pressure transducer along with the appropriate calibration hardware, similar benefits of ease and speed can be applied to air tool calibration.

Contact TechSales@norbar.com or your distributor for further details.

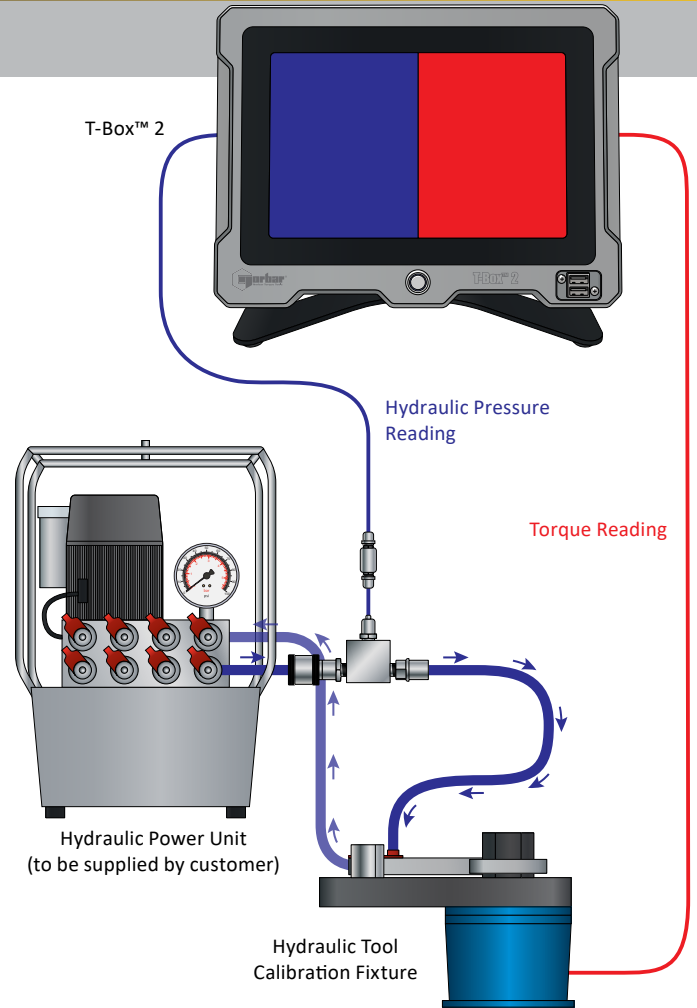
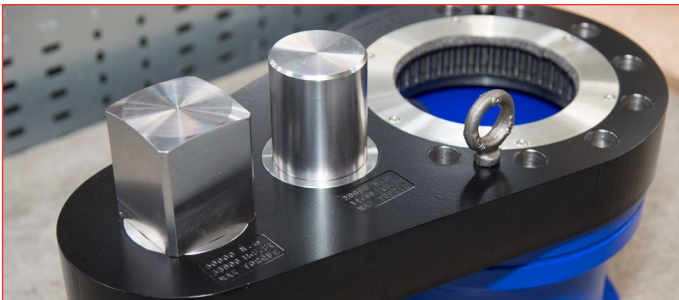

4 TRANSDUCERS FOR USE WITH 80031 / 80030

| | |
|------------|-------------------------------------|
| 50703.xxx* | 250 - 2,500 N·m, 1½" sq. dr. M/F |
| 50704.xxx* | 250 - 2,500 lbf-ft, 1½" sq. dr. M/F |
| 50599.xxx* | 500 - 5,000 N·m, 1½" sq. dr. M/F |
| 50630.xxx* | 500 - 5,000 lbf-ft, 1½" sq. dr. M/F |
| 50669.xxx* | 700 - 7,000 N·m, 1½" sq. dr. M/F |

4 TRANSDUCERS FOR USE WITH 80029 / 80030

| | |
|------------|--|
| 50776.xxx@ | 1,000 - 10,000 N·m, 2½" sq. dr. M/F |
| 50777.xxx@ | 1,000 - 10,000 lbf-ft, 2½" sq. dr. M/F |
| 50797.xxx@ | 2,500 - 25,000 N·m, 2½" sq. dr. M/F |
| 50781.xxx@ | 5,000 - 50,000 N·m, 2½" sq. dr. M/F |
| 50798.xxx@ | 25,000 lbf-ft, 2½" sq. dr. M/F |

4 TRANSDUCERS FOR USE WITH 80032

| | |
|-----------|--|
| 50782.xxx | 6,000 - 60,000 lbf-ft, 3½" sq. dr. M/F |
| 50783.xxx | 8,000 - 80,000 N·m, 3½" sq. dr. M/F |

Harsh Environment Transducers available on request.

4 CALIBRATION FIXTURE ACCESSORIES

| | |
|-----------|--|
| 56026.IND | 730 bar Pressure Transducer ADDCALPOINTS.NEW does not apply to pressure transducers |
|-----------|--|



56026.IND 730 bar Pressure Transducer

12 ADDITIONAL CALIBRATION

The transducers shown include clockwise only calibration from 10% to 100% of rated capacity. For other calibration options, see below:

*ADDCALPOINTS.NEW

Additional calibration steps below 10% of rated capacity to 2% for transducers up to 7,000 N·m (5,000 lbf-ft) when ordered with new unit

@SECCAL.CW

Secondary calibration in one direction on static transducers with 2½" square drives to extend the range below 10% of the rated capacity, when ordered with new unit

SECCAL.CW+CCW

Secondary calibration in two directions on static transducers with 2½" square drives to extend the range below 10% of the rated capacity, when ordered with new unit



HEXAGON TO SQUARE ADAPTORS

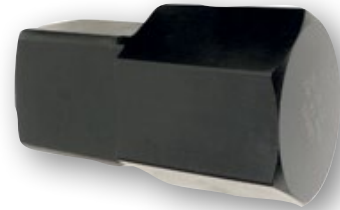

Hexagon to Square Adaptor

| 9 | HEXAGON TO SQUARE ADAPTORS - METRIC |
|-----------|--|
| 29619.24 | 24 mm Hex to 1½" sq. dr. (Max 3,000 N·m) |
| 29619.27 | 27 mm Hex to 1½" sq. dr. (Max 4,000 N·m) |
| 29619.30 | 30 mm Hex to 1½" sq. dr. (Max 4,000 N·m) |
| 29619.32 | 32 mm Hex to 1½" sq. dr. (Max 4,900 N·m) |
| 29619.36 | 36 mm Hex to 1½" sq. dr. (Max 7,000 N·m) |
| 29619.41 | 41 mm Hex to 1½" sq. dr. (Max 8,700 N·m) |
| 29619.46 | 46 mm Hex to 1½" sq. dr. (Max 8,700 N·m) |
| 29619.50 | 50 mm Hex to 1½" sq. dr. (Max 8,700 N·m) |
| 29619.55 | 55 mm Hex to 1½" sq. dr. (Max 8,700 N·m) |
| 29619.60 | 60 mm Hex to 1½" sq. dr. (Max 8,700 N·m) |
| 29619.65 | 65 mm Hex to 1½" sq. dr. (Max 8,700 N·m) |
| 29619.70 | 70 mm Hex to 1½" sq. dr. (Max 8,700 N·m) |
| 29619.75 | 75 mm Hex to 1½" sq. dr. (Max 8,700 N·m) |
| 29619.80 | 80 mm Hex to 1½" sq. dr. (Max 8,700 N·m) |
| 29620.50 | 50 mm Hex to 2½" sq. dr. (Max 18,500 N·m) |
| 29620.55 | 55 mm Hex to 2½" sq. dr. (Max 25,000 N·m) |
| 29620.60 | 60 mm Hex to 2½" sq. dr. (Max 32,000 N·m) |
| 29620.65 | 65 mm Hex to 2½" sq. dr. (Max 36,000 N·m) |
| 29620.70 | 70 mm Hex to 2½" sq. dr. (Max 36,000 N·m) |
| 29620.75 | 75 mm Hex to 2½" sq. dr. (Max 36,000 N·m) |
| 29620.80 | 80 mm Hex to 2½" sq. dr. (Max 59,000 N·m) |
| 29620.85 | 85 mm Hex to 2½" sq. dr. (Max 59,000 N·m) |
| 29620.90 | 90 mm Hex to 2½" sq. dr. (Max 59,000 N·m) |
| 29620.95 | 95 mm Hex to 2½" sq. dr. (Max 59,000 N·m) |
| 29620.100 | 100 mm Hex to 2½" sq. dr. (Max 52,000 N·m) |
| 29620.105 | 105 mm Hex to 2½" sq. dr. (Max 52,000 N·m) |
| 29620.110 | 110 mm Hex to 2½" sq. dr. (Max 52,000 N·m) |
| 29620.115 | 115 mm Hex to 2½" sq. dr. (Max 52,000 N·m) |
| 29620.130 | 130 mm Hex to 2½" sq. dr. (Max 52,000 N·m) |

| 9 | HEXAGON TO SQUARE ADAPTORS - IMPERIAL |
|-----------|---|
| 29623.I20 | 1¼" Hex to 1½" sq. dr. (Max 4,900 N·m) |
| 29623.I23 | 1⅞" Hex to 1½" sq. dr. (Max 7,000 N·m) |
| 29623.I26 | 1⅝" Hex to 1½" sq. dr. (Max 8,700 N·m) |
| 29623.I29 | 1⅜" Hex to 1½" sq. dr. (Max 8,700 N·m) |
| 29623.I32 | 2" Hex to 1½" sq. dr. (Max 8,700 N·m) |
| 29623.I33 | 2⅞" Hex to 1½" sq. dr. (Max 8,700 N·m) |
| 29623.I35 | 2⅜" Hex to 1½" sq. dr. (Max 8,700 N·m) |
| 29623.I38 | 2⅝" Hex to 1½" sq. dr. (Max 8,700 N·m) |
| 29623.I41 | 2⅞" Hex to 1½" sq. dr. (Max 8,700 N·m) |
| 29624.I35 | 2⅜" Hex to 2½" sq. dr. (Max 25,000 N·m) |
| 29624.I38 | 2⅝" Hex to 2½" sq. dr. (Max 32,000 N·m) |
| 29624.I40 | 2½" Hex to 2½" sq. dr. (Max 36,000 N·m) |
| 29624.I41 | 2⅞" Hex to 2½" sq. dr. (Max 36,000 N·m) |
| 29624.I44 | 2¾" Hex to 2½" sq. dr. (Max 36,000 N·m) |
| 29624.I47 | 2⅝" Hex to 2½" sq. dr. (Max 36,000 N·m) |
| 29264.I48 | 3" Hex to 2½" sq. dr. (Max 36,000 N·m) |
| 29624.I50 | 3⅝" Hex to 2½" sq. dr. (Max 59,000 N·m) |
| 29624.I56 | 3½" Hex to 2½" sq. dr. (Max 59,000 N·m) |
| 29624.I62 | 3⅞" Hex to 2½" sq. dr. (Max 52,000 N·m) |
| 29624.I68 | 4¼" Hex to 2½" sq. dr. (Max 52,000 N·m) |
| 29624.I74 | 4⅝" Hex to 2½" sq. dr. (Max 52,000 N·m) |
| 29624.I80 | 5" Hex to 2½" sq. dr. (Max 52,000 N·m) |
| 29624.I86 | 5⅝" Hex to 2½" sq. dr. (Max 52,000 N·m) |
| 29624.I98 | 6⅞" Hex to 2½" sq. dr. (Max 52,000 N·m) |

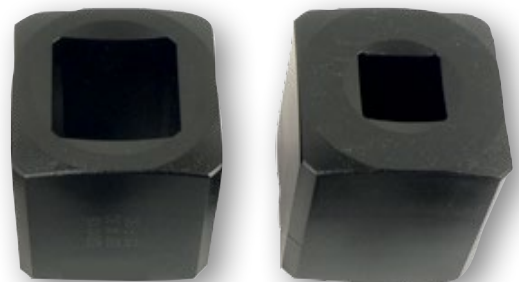

Sleeve Adaptors

| 9 | SLEEVE ADAPTORS |
|---------|---|
| 86034.4 | Adaptor 1½" Male sq. dr. ¾" Female sq. |
| 21214 | Adaptor 1½" Male sq. dr. 1" Female sq. |
| 290100 | Adaptor 2½" Male sq. dr. ¾" Female sq. |
| 290101 | Adaptor 2½" Male sq. dr. 1" Female sq. |
| 29617 | Adaptor 2½" Male sq. dr. 1½" Female sq. |
| 290103 | Adaptor 3½" Male sq. dr. 1½" Female sq. |
| 29618 | Adaptor 3½" Male sq. dr. 2½" Female sq. |

Special 'Engineer to Order' hexagon and square adaptors available on request.



TOOL CONTROLLERS

Tool Controllers 110

Norbar's Tool Controllers are used in a range of industries and applications where a high degree of tool control, automation or data gathering is required. In addition to the input of torque data, the controller can simultaneously take data from other sensors, such as angle or pressure, and the various inputs analysed together. Examples of Norbar Tool Controllers are shown on page 110. In fact, these products are highly customised and will be engineered and programmed for our customers' specific requirements.

For more details please visit the Engineer to Order section of the Norbar website at: www.norbar.com/Services/Engineer-to-Order or contact your Norbar distributor to discuss your requirements.



DELTA

| | | |
|-----------------|---------------------|-----------------------|
| 10 | WORK ID | TORQUE TRANSDUCER |
| | 123456789 QWERTY | CONNECT TRANSDUCER |
| 0 | 0.00 | RESET |
| | 0N.m | 0.00° |
| CYCLES RESET | 3400 | 96 N.m |
| 10.0 s | TORQUE ZERO | PEAK RESET |
| 0.0 s | ZERO PRESSURE | 0.0 BAR |



TOOL CONTROLLERS

Tool Controller for 1 to 8 Simultaneous Spindle Options

Option for PneuTorque® manual or remote tools fitted with annular torque and angle transducer and solenoid operated valve assemblies

- Option for AC Servo remote tools fitted with or without annular torque & angle transducers
- 10" touchscreen HMI & PLC housed in a painted steel enclosure for indoor or workshop use
- Data entry fields for operation name, time, date and multiple torque limits & angle / turns limits
- Optional torque transducer ports for '.LOGA' or '.LOG' connection
- Single or twin solenoid ports for connection to PneuTorque® manual or remote tools
- One hand pendant input port
- Multiple step sequence programming to include torque & angle limits and individual joint fail checking
- One RS232 serial output
- One USB data output with optional USB powered barcode reader input
- Real time torque & angle streaming for all required spindle options
- Tool operation data capture and output in CSV format onto external USB drive, for the generation of customer test reports & graphs
- Remote observation mode via LAN port
- Emergency stop button

| 4 | TRANSDUCER LEADS FOR TOOL CONTROLLERS |
|------------|---|
| 60308.400 | PRO-LOG, TST, TTT, T-Box XL & T-Box 2 to Torque & Angle Annular Transducers |
| 60308.600 | PRO-LOG, TST, TTT, T-Box XL & T-Box 2 to Torque & Angle Annular Transducers |
| 60308.1000 | PRO-LOG, TST & TTT to Torque & Angle Annular Transducers |

Tool Controller for Valve Testing - for Pneumatic Tools

Tool controller for PneuTorque® remote tools fitted with annular torque & angle transducer and solenoid operated valve assemblies.

- 10" touchscreen HMI & PLC housed in a painted steel enclosure for indoor / workshop use
- Data entry fields for test valve details, operator, time, date, torque limits & angle / turns limits
- Forward / reverse cycling to user programmable number of cycles, variable up to 32,000°
- One torque transducer port, for '.LOGA' or '.LOG' connection
- One twin solenoid port for connection to valve assembly
- One hand pendant input port
- Two proximity limit switch ports (for use where angle is not measured at the transducer)
- One customer pressure sensor port, (2mV/V), for data recording (not tool shut-off)
- One RS232 + one USB data output ports
- Real time torque & angle or torque & turns data streaming
- Test data capture and output in CSV format onto external USB drive, for the generation of customer test reports & graphs
- Emergency stop button and torque overload limit function

The models above are a sample of the controllers that Norbar produce. Please contact Norbar for your special requirements.

| DIESEL ENGINE TYPE 1 | | | | | | PROGRAM SCREEN | | | | | | | |
|----------------------|------------|---------------|-------|-----------|----------|-------------------|-------|-------|-------|-------|-------|-------|-------|
| STEP | TORQUE MAX | TORQUE TARGET | ANGLE | SPEED RPM | MAX TIME | SPINDLE(S) ENABLE | | | | | | | |
| 1 | 200 | 100 | 0 | 10 | 30 | 1 ON | 2 ON | 3 ON | 4 ON | 5 OFF | 6 OFF | 7 OFF | 8 OFF |
| 2 | 800 | 500 | 0 | 1 | 2 | 1 ON | 2 ON | 3 ON | 4 ON | 5 OFF | 6 OFF | 7 OFF | 8 OFF |
| 3 | 1200 | 1000 | 90 | 1 | 2 | 1 ON | 2 ON | 3 ON | 4 ON | 5 OFF | 6 OFF | 7 OFF | 8 OFF |
| 4 | 2500 | 2000 | 180 | 1 | 2 | 1 ON | 2 ON | 3 ON | 4 ON | 5 OFF | 6 OFF | 7 OFF | 8 OFF |
| 5 | 0 | 0 | 0 | 0 | 0 | 1 OFF | 2 OFF | 3 OFF | 4 OFF | 5 OFF | 6 OFF | 7 OFF | 8 OFF |
| 6 | 0 | 0 | 0 | 0 | 0 | 1 OFF | 2 OFF | 3 OFF | 4 OFF | 5 OFF | 6 OFF | 7 OFF | 8 OFF |
| 7 | 0 | 0 | 0 | 0 | 0 | 1 OFF | 2 OFF | 3 OFF | 4 OFF | 5 OFF | 6 OFF | 7 OFF | 8 OFF |
| 8 | 0 | 0 | 0 | 0 | 0 | 1 OFF | 2 OFF | 3 OFF | 4 OFF | 5 OFF | 6 OFF | 7 OFF | 8 OFF |
| 9 | 0 | 0 | 0 | 0 | 0 | 1 OFF | 2 OFF | 3 OFF | 4 OFF | 5 OFF | 6 OFF | 7 OFF | 8 OFF |
| 10 | 0 | 0 | 0 | 0 | 0 | 1 OFF | 2 OFF | 3 OFF | 4 OFF | 5 OFF | 6 OFF | 7 OFF | 8 OFF |

The Tool Controller shut-off system is supplied in a wall box for 'External Control' versions of the Norbar PTM series of tools. This can give a much greater range of functionality than is possible on the 'Internal Control' version of the tool.



Tool Controller with Hand Pendant from Valve Testing Controls Kit for use with AC servo drive or pneumatic drive tools

| | |
|--|---|
| 8 | 3 WAY SHUT-OFF VALVE |
| 28943 | 3 Way Shut-off Valve 10 BAR Maximum Air Pressure |
| 11 | TWIN SOLENOID VALVE ASSEMBLY |
| 60309 | Twin Solenoid Valve Assembly for 108 Remote Tools |
| 60310 | Twin Solenoid Valve Assembly for 72 Remote Tools |
| 60298.600* | Solenoid Lead for twin valve assembly, 6 m |
| 60298.1000* | Solenoid Lead for twin valve assembly, 10 m |
| * For use with special tool controllers. | |
| 11 | TOOL CONTROLLER (TTT based) |
| 60244 | Shut-off system in wall box |
| Tool Controllers are supplied without leads. | |
| 61127.600 | Lead for PTM Series Tool |
| 61126.600 | Transducer Lead for PT Series Tool |
| 61128.600 | Solenoid Lead for PT Series Tool (for single valve) |

Other lead lengths can be ordered at an additional cost. Both 61126.600 and 61128.600 are required to control a PT Series tool with a tool controller.



VALVE TESTING

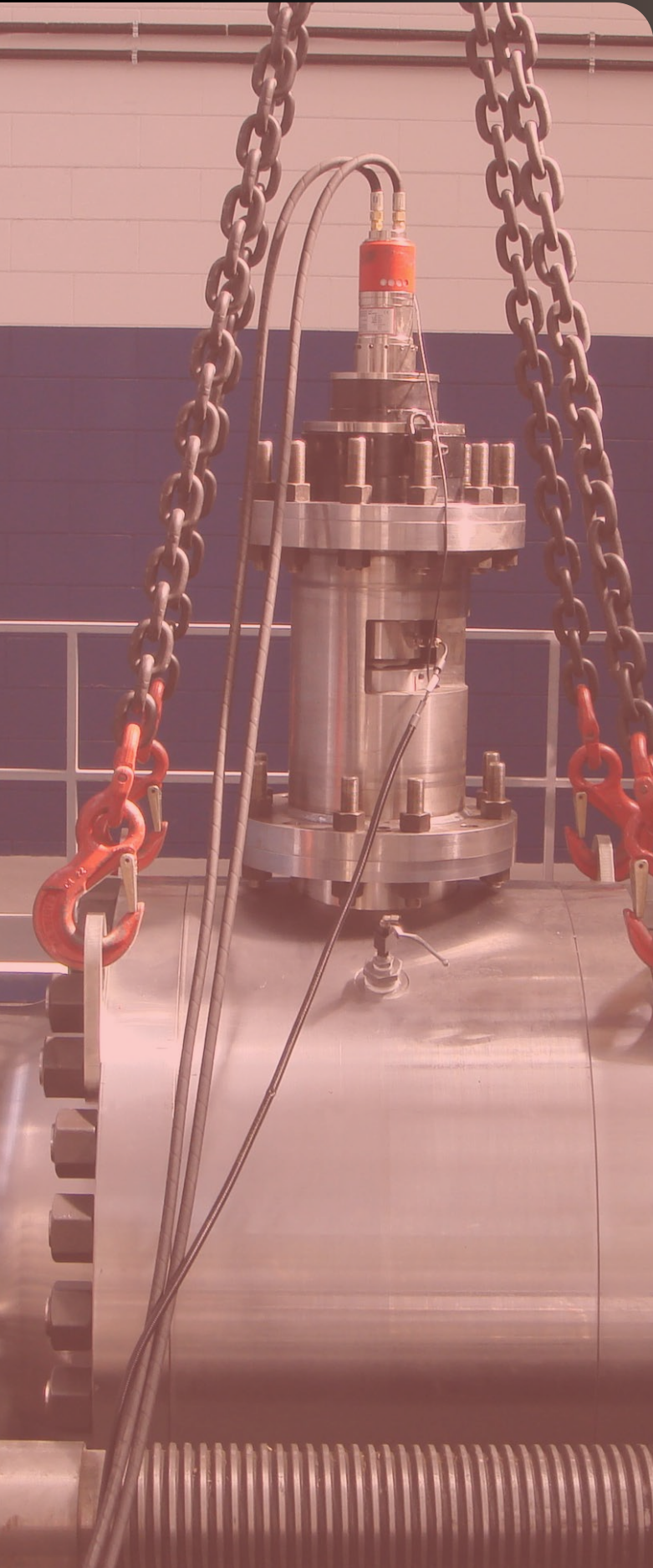

Valve Testing & Actuation 112

Norbar's Valve Testing System has been designed to monitor and control the opening and closing of ball valves and gate valves by means of torque and/or angle measurement with optional proximity switches for added security when required.



VALVE TESTING & ACTUATION

VALVE TESTING SYSTEM

Engineered to Order Valve Testing System

Typical applications include the testing of Ball Valves requiring cyclical rotation 0 - 90° / 90 - 0°, whilst recording torque vs angle data. Testing of Gate Valves / Valve Actuators by opening and closing whilst recording torque vs angle / turns data. The test must be remotely controlled from outside of the test chamber, where the test valve is pressurised.

- 10" touchscreen HMI & PLC housed in painted steel enclosure for indoor / workshop use
- Test data capture and output in CSV format onto external USB drive, time and date stamped
- Up to 20 targets can be set against a test
- Generate customer test reports and produce graphs
- Real time torque & angle or torque & turns data streaming via RS232 serial port
- Using the AC servo drive an optional lock can be added to hold a butterfly valve at a prescribed angle
- Dedicated input ports for pressure, temperature and proximity sensors
- Controller available as separate component to upgrade existing valve testing kits
- Automatic recognition of Smart transducers
- Forward / reverse cycling - user programmable number of cycles, variable up to 32,000 sweeps
- Emergency stop button and torque overload limit function
- Torque Range: 100 - 300,000 N·m (capacities up to 500,000 available on application)
- Option to include network capability
- Operates with Pneumatic, or AC servo drive tools
 - AC Servo brushless motor is quiet and maintenance free
 - Pneumatic tool shut-off control via solenoid operated valves
 - Annular torque & angle transducers are available to fit either tool type

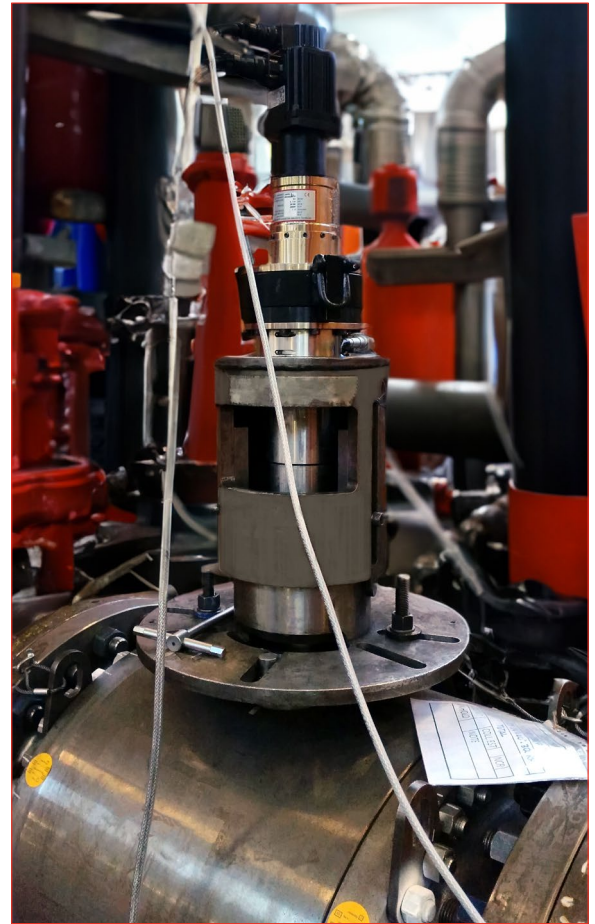

Example of an engineered to order Valve Testing System in application

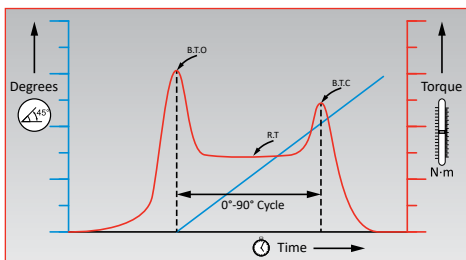

This diagram represents what we would expect to occur during a "break to open" to "break to close" cycle of a typical ball valve, with R.T. being the "run torque".

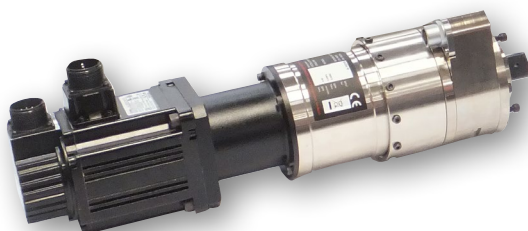

Actuator performance testing is also available through our ETO offering:

Working with the same proven hardware as the Valve Testing equipment, Norbar's ETO section have developed an effective means to test and evaluate rotary valve actuators, giving the ability to test rotary actuators from 50 to 300 kN·m with stepped loading in both the CW and CCW directions.

The end user has the ability to map the performance (torque and angular position) of the actuator over full angular sweep, with the load being locked off at user set points across the range of the selected tool device with all data being recorded in an easy to read .CSV format.



HARSH ENVIRONMENT INSTRUMENTS



Harsh Environment Instrument 114
 TTL-HE Instrument and Transducer Kits 114
 Harsh Environment Transducers 115
 Intervention Tool Test Pots 116
 Intervention Tool Verification Kits 116
 Multipliers for Subsea 116

Norbar has worked closely with the oil and gas industry to produce a range of torque instruments and transducers suitable for use in the harshest environments such as ship decks, oil rigs and refineries. Norbar uses a variety of corrosion resistant materials, high specification connectors and sealing techniques meaning that products in our HE range can be used in such environments without impairing their performance or life span. Although originally designed to meet the needs of the oil and gas industry, Norbar’s HE range is the ideal choice whenever it is necessary to apply or measure torque outdoors in potentially wet or dusty conditions.



HARSH ENVIRONMENT INSTRUMENT



TTL-HE is a portable torque measuring instrument designed for use in harsh environments. The TTL-HE operating on battery power with one of the 'HE' range of transducers connected, has an ingress protection rating of IP65/IP67. Typical operating environments are where high humidity, water or salt water spray and dust may be an issue. Features include; 10 measurement modes, 13 units of torque (with additional user units feature), 12 pairs of limits and text displayed in 11 languages.

- Instrument accuracy of $\pm 0.05\%$ ($\pm 0.1\%$ when below 10% of transducer capacity)
- System accuracy with a typical Norbar transducer, $\pm 0.5\%$ from 20% of transducer capacity
- IP65/67 rated
- Bi-directional calibration
- Battery power use in harsh environments (mains supply for charging)
- All features are in common with TST and TTT instruments
- Supplied in IP67 rated carry case
- 5 digit resolution for all Norbar transducers
- 240 x 64 pixel dot matrix display with update rate of twice per second
- Please contact Norbar for full details of available transducers

4 HARSH ENVIRONMENT RANGE

43217 TTL-HE Instrument (inc. IP67 rated carry case)
Supplied with clockwise and counter-clockwise calibration.

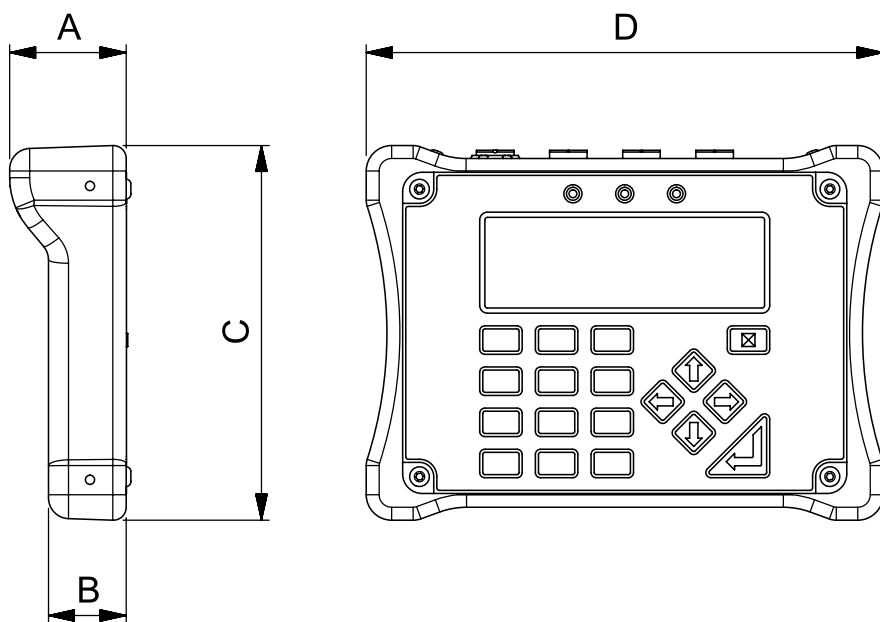

| Model | TTL-HE | |
|-----------------|--------|-----|
| Part Number | 43217 | |
| Dimensions (mm) | A | 45 |
| | B | 30 |
| | C | 145 |
| | D | 200 |
| Weight (kg) | 4.9 | |

TTL-HE INSTRUMENT AND TRANSDUCER KITS



4 TTL-HE INSTRUMENT AND TRANSDUCER KITS

| | |
|-----------|--|
| 60287.LOG | 5,000 N·m M/M TTL-HE Kit, inc. Lead (Class 4) |
| 60295.LOG | 10,000 N·m M/M TTL-HE Kit, inc. Lead (Class 5) |
| 60289.LOG | 40,000 N·m M/M TTL-HE Kit, inc. Lead (Class 7) |

Note: Kits for use with Intervention Tool Test Pots



HARSH ENVIRONMENT TRANSDUCERS



The accuracy and quality of the Norbar torque transducers has made them the first choice of many calibration laboratories throughout the world. The Harsh Environment range of transducers has been specifically designed for use with the Norbar TTL-HE instrument.

- Class 1 accuracy over the 'Primary' classification range ($\pm 0.5\%$ of reading from 20 to 100% of full scale)
- Stainless steel design with Smart intelligence
- IP65/IP67 rated
- Bi-direction calibration as standard

Harsh Environment Annular Transducers are available as ETO (Engineer to Order).



| 4 | STATIC TRANSDUCERS |
|------------|--|
| 50787.xxx | 300 - 3,000 N·m, 1½" M/F sq. dr. |
| 50751.xxx* | 300 - 3,000 N·m, 1½" M/M sq. dr. |
| 50705.xxx | 500 - 5,000 N·m, 1½" M/F sq. dr. |
| 50729.LOG | 500 - 5,000 N·m, 1½" M/M sq. dr. |
| 50706.xxx | 500 - 5,000 lbf-ft, 1½" M/F sq. dr. |
| 50728.xxx | 1,000 - 10,000 N·m, 2½" M/F sq. dr. |
| 50788.xxx | 1,000 - 10,000 N·m, 2½" M/ 2" M sq. dr. |
| 50789.xxx | 1,500 - 15,000 N·m, 2½" M/ 2½" M sq. dr. |
| 50726.xxx | 2,500 - 25,000 N·m, 3½" M/M sq. dr. |
| 50727.xxx | 4,000 - 40,000 N·m, 3½" M/M sq. dr. |
| 50743.xxx* | 10,000 - 100,000 lbf-ft, 3½" M/M sq. dr. |

* Suitable for use in Hydraulic Test Pots.

* UKAS accredited calibration up to 80,000 lbf-ft. A non-accredited value at 100,000 lbf-ft is extrapolated and provided for reference only. Static Transducers 3,000 N·m and above supplied in carry case.

Designed for use with the Harsh Environment Instrument range (TTL-HE) of products

| 4 | INSTRUMENTATION LEADS |
|-----------|---|
| 60245.200 | TTL-HE to HE Transducer |
| 60250.200 | TTL-HE to Norbar Static & Annular Transducers |
| 60263.200 | TTL-HE to Rotary Transducers |
| 60266.200 | HE Transducer to TTT, TST and T-Box 2 |
| 60261.200 | Serial Data Lead for TTL-HE |

Other lengths can be ordered at an additional cost.

Note: The system should be calibrated with the increased length lead, as calibration may be affected.

Note: The maximum permissible cable length 15 m for Transducer Leads, 7 m if using 60266 with a T-Box™ XL. Contact Norbar for further details.

Static Transducers - Male to Male (M/M) Square Drives

| Model | 3,000 N·m 5,000 N·m | 10,000 N·m | 15,000 N·m | 25,000 N·m 40,000 N·m 100,000 lbf-ft |
|-----------------|------------------------------------|------------|------------|---|
| Part Number | 50751.xxx 50729.xxx | 50788.xxx | 50789.xxx | 50726.xxx 50727.xxx 50743.xxx |
| Dimensions (mm) | ØA | 95 | 110 | 164 |
| | B | 68 | 75 | 103 |
| | C | 168 | 200 | 225 |
| | D | 38 | 57 | 57 |
| | E | 84 | 101 | 101 |
| | F | 38 | 57 | 58 |
| Weight (kg) | 3.4 (3,000 N·m) 5.0 (5,000 N·m) | 11.4 | 11.4 | 21.5 (25,000 N·m) 22.0 (40,000 N·m) 25.0 (100,000 lbf-ft) |

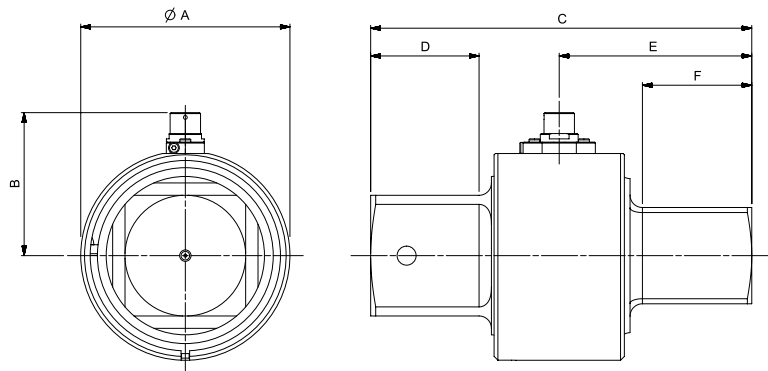

Static Transducers - Male to Female (M/F) Square Drives

| Model | 3,000 N·m 5,000 N·m 5,000 lbf-ft | 10,000 N·m |
|-----------------|--|------------|
| Part Number | 50787.xxx 50705.xxx 50706.xxx | 50728.xxx |
| Dimensions (mm) | ØA | 95 |
| | B | 68 |
| | C | 160 |
| | D | 41 |
| | E | 84 |
| | F | 38 |
| Weight (kg) | 5.0 | 9.1 |

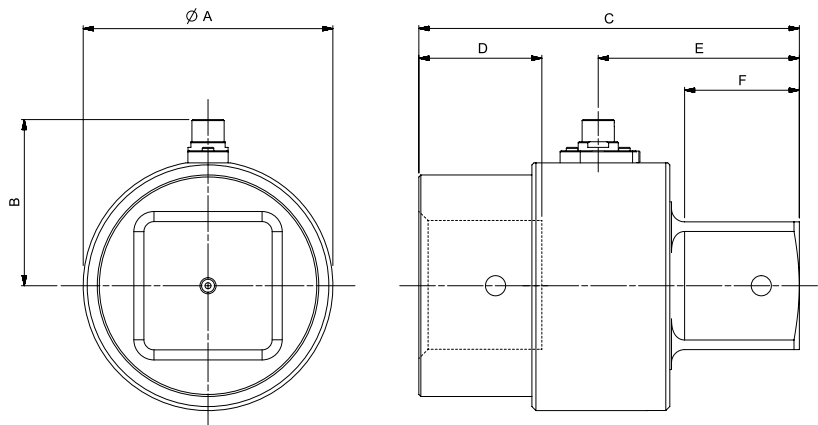



INTERVENTION TOOL TEST POTS

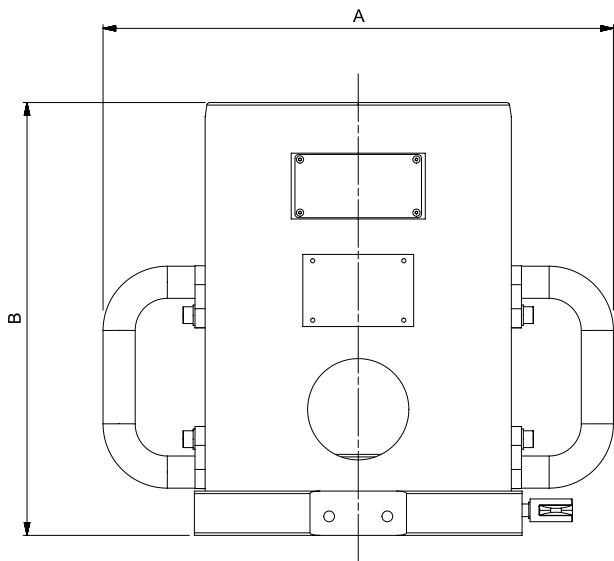

These reaction pots allow for the accurate testing of API rotary intervention tools.

- Conform to ISO 13628-8:2002 and API 17D
- Customer specific solutions also available
- Lightweight construction, major components made in aluminium
- Incorporated lifting handles
- Eye bolts provided on larger units



| 4 | INTERVENTION TOOL TEST POTS |
|-------|--|
| 80019 | ISO 13628-8:2002 Class 4 Intervention Tool Test Pot |
| 80024 | ISO 13628-8:2002 Class 5 Intervention Tool Test Pot |
| 80025 | ISO 13628-8:2002 Class 6 Intervention Tool Test Pot |
| 80020 | API 17D Class 7 Intervention Tool Test Pot |

| Model | Class 4 | Class 5 | Class 6 | Class 7 |
|-----------------|---------|---------|---------|---------|
| Part Number | 80019 | 80024 | 80025 | 80020 |
| Dimensions (mm) | A | 372 | 403 | 428 |
| | B | 215 | 246 | 326 |
| Weight (kg) | 17.5 | 22.0 | 51.0 | 48.0 |

INTERVENTION TOOL VERIFICATION KITS



| 4 | INTERVENTION TOOL TORQUE VERIFICATION KIT |
|-----------|--|
| 60278.xxx | 3,000 N-m ISO 13628 Class 4 Intervention Tool Torque Verification Kit |
| 60281.xxx | 10,000 N-m ISO 13628 Class 5 Intervention Tool Torque Verification Kit |
| 60280.xxx | 40,000 N-m API 17D Class 7 (short) Intervention Tool Test Kit |

Other test pots and Torque Verification Kits are available for standard and non-standard API Intervention tool test and verification. Please contact Norbar.

MULTIPLIERS FOR SUBSEA

| 4 | MULTIPLIERS FOR INTEGRATION INTO SUBSEA INTERVENTION TOOLS |
|-------|--|
| 77331 | HT5 5:1 for Subsea Intervention Tools |
| 77301 | HT5 5:1 for Subsea Splined Output |

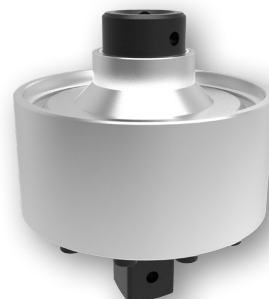

| Model | HT5 5:1 Subsea | |
|-----------------|----------------|-----|
| Part Number | 77331 77301 | |
| Dimensions (mm) | D | 119 |
| | H | 106 |
| Weight (kg) | TBC | |

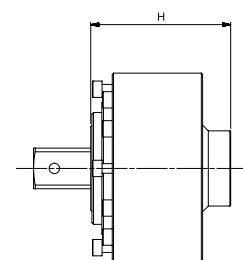
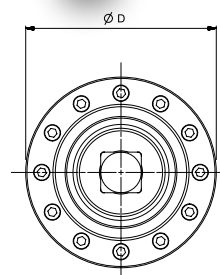



ENGINEER TO ORDER

Norbar's wide range of standard equipment may not meet your exact requirements as there are applications when something special is required.

As an ISO 9001 certified company, Norbar will undertake the design and manufacture of special equipment against agreed customer specifications.

These projects range from modified torque wrench end fittings to complete torque and angle control of valve testing kits. Relevant safety directives are applied where appropriate, leading to well engineered reliable products that are designed to make tasks safer and easier.

For more information on Norbar's Engineer to Order service please e-mail your enquiry to TechSales@norbar.com or visit the Engineer to Order section of the Norbar website at: www.norbar.com/Services/Engineer-to-Order

ETO Example 1 - Specialist Reaction to Assist Rail Track Bolting 118
 ETO Example 2 - Offset Gearbox to fit PTS-72-2000 for Train Traction Links 118
 ETO Example 3 - Custom Class 7 Multiplier Kit with Hydraulic Latching for Subsea . . . 119
 ETO Example 4 - Subsea Vertical use Intervention Torque Multiplier 119
 ETO Example 5 - Class 4-6 & 4-7 (long & short) Subsea Torque Multiplier Kit 120
 ETO Example 6 - Special Cranked Sliding Reaction for use with a PTS-119-6000 120
 ETO Example 7 - PT12 Kit with 15 m Single Direction Remote Control 121
 Bespoke Reaction Arms 121





ETO EXAMPLE 1 - SPECIALIST REACTION TO ASSIST RAIL TRACK BOLTING

Project Number: Q5321

Introduction & Application

Specialist reaction to assist in the assembly and disassembly of rail track bolts (assembled using an impact tool) used to secure stock during transit. This is to replace a heavy electric impact tool that was no longer preferred by the end user. Long studding made this a unique application therefore a bespoke reaction design was required.

Solution

EBT-80-2700 was fitted with a special reaction and a deep socket. The reaction can be placed over the stud and nut prior to engaging with the tool, allowing the tool to be more manoeuvrable. As the reaction engages with the application, the bespoke lock ring ensures that the tool does not disengage with the reaction.



Technical Specification / Data Highlights

We were able to take advantage of our in-house 3D printing facility to ensure compliance with both the customers expectations, and of course the application.

ETO EXAMPLE 2 - OFFSET GEARBOX TO FIT PTS-72-2000 FOR TRAIN TRACTION LINKS

Project Number: Q4191

Introduction & Application

Railway maintenance application for removal and re-fitting of train traction link bolts, where bolt access is obstructed by the anti-roll bar.

Solution

PTS-72-2000 with offset gearbox kit.



Technical Specification / Data Highlights

M36 – 55 mm A/F hexagon head bolts tighten to 980 N·m / untighten at up to 2,000 N·m.

Q4191 kit includes offset gearbox having 3 gears, LH & RH reaction arms, PTS-72-2000 & Lubro control unit # 16074.



ETO EXAMPLE 3 - CUSTOM CLASS 7 MULTIPLIER KIT WITH HYDRAULIC LATCHING FOR SUBSEA

Project Number: Q3730

Introduction & Application

Oil & Gas industry requirement for a custom Class 7 torque multiplier kit with hydraulic latching, for integration into a pressure compensated subsea intervention tool.

Solution

Custom torque multiplier kit comprising:-

- Custom Class 7 nose housing with 2-stage torque multiplication gearing.
- HT5 / 5 torque multiplier & connecting input shaft.
- Hydraulic latching system with fail-safe spring return cylinders.

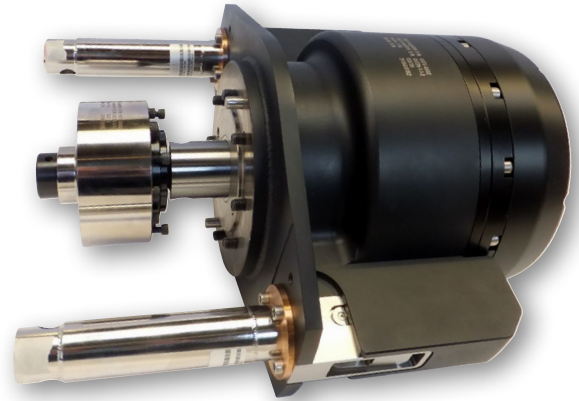

Technical Specification / Data Highlights

Class 7; 34,000 N·m (25,000 lbf·ft) with 61:1 torque multiplication.

Customised nose to suit end user’s special receptacle (non-standard narrow reaction wings).

Sealed for use to 3,000 m (except input end), for connection to customer pressure compensation system.

High strength, lightweight materials for total weight in air of 59.9 kg.

ETO EXAMPLE 4 - SUBSEA VERTICAL USE INTERVENTION TORQUE MULTIPLIER

Project Number: Q5227

Introduction & Application

Oil & Gas industrial requirement for a subsea intervention torque multiplier (Super Duplex) with valve protection for vertical use only.

| INPUT | OUTPUT INTERFACE | OUTPUT RATED |
|--|--|---|
| Class 4 to API 17D/ISO 13628-8 (2,700 N·m max. input) | Class 7 (short) to API 17D (1st edition) - 45,000 N·m normal operation / 67,500 N·m overload torque | 45,000 N·m normal operation / 67,500 N·m overload torque |

Technical Specification / Data Highlights

- Torque Multiplication: 25:1 (28.41:1 true gear ratio)
- Depth rating: 1,500 m with integral pressure compensation
- Weights air/water: 160/135 kg
- Latching: Class 4 receptacle latching flange/No latching on class 6/7 (available as an option)
- Materials: Outside components Super Duplex (Norsok M-630/650)/Stainless Steel and POM nose bumper





ETO EXAMPLE 5 - CLASS 4-6 & 4-7 (LONG & SHORT) SUBSEA TORQUE MULTIPLIER KIT

Project Number: Q4636.01

Introduction & Application

Oil & Gas industry requirement for a subsea intervention torque multiplier kit, for horizontal and vertical use, and with the following interfaces/ratings:

| INPUT | OUTPUT INTERFACE | OUTPUT RATED |
|------------------------------------|---|----------------------------|
| Class 4 to API 17D/ ISO 13628-8 | Class 7 (long) to API 17D (2nd edition) / ISO 13628-8 | 33,895 N·m / 25,000 lbf·ft |
| | Class 7 (short) to API 17D (1st edition) | 33,895 N·m / 25,000 lbf·ft |
| | Class 6 to API 17D (2nd edition) / ISO 13628-8 | 13,558 N·m / 10,000 lbf·ft |



Solution

Modular kit with interchangeable noses / output drives for the three configurations

Technical Specification / Data Highlights

Torque Multiplication: 12.93:1
 Depth rating: 3,000 m with integral pressure compensation

Weights air/water: Class 7 long 79.5/60.5 kg
 Class 6 66.5/51.8 kg
 Class 7 short 61.5/48.9 kg
 Latching: Class 4 receptacle latching flange/
 No latching on class 6/7 (available as an option)

ETO EXAMPLE 6 - SPECIAL CRANKED SLIDING REACTION FOR USE WITH A PTS-119-6000

Project Number: Q4780

Introduction & Application

Customer required a reaction arm to work with a powered multiplier, to drive a series of pins positioned around a diameter, where the only point of reaction was the adjacent pin.

Solution

Special cranked sliding reaction for use with a PTS-119-6000

Technical Specification / Data Highlights

Solution includes a slave socket with a plain bore to clear 1 5/8" AF hexagon.

Reaction angled at 20° to the tool axis, with travelling centres to suit reaction off adjacent pin.

The axial travel is incorporated to accommodate potential pin movement on future wellhead designs.

The solution is designed to be used both in a workshop, and topside. Provided with a chemical black finish, the reaction will be cleaned and oiled after use if used in an offshore environment.

Max torque – 4,000 N·m

Weight – approx. 10.5 kg

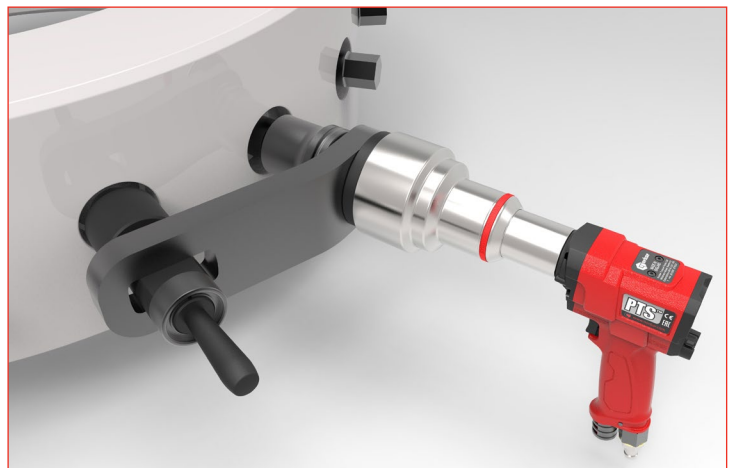



ETO EXAMPLE 7 - PT12 KIT WITH 15 M SINGLE DIRECTION REMOTE CONTROL

Project Number: Q5174

Introduction & Application

Power tool required to rotate large 3 m gas turbine rotors at up to 34,000 N·m with 15 m remote operation.

Solution

PT 12 single speed pneumatic tool, 9,500 - 34,000 N·m range, 2½" square drive and direction change at tool.

Special control unit with air regulator / lubricator / filter, safety isolator valve on input, solenoid control valve on output and 15 m hose, USA power supply and remote grip switch pendant with 15 m lead.



BESPOKE REACTION ARMS

Norbar have a dedicated team ready to design any special bespoke reaction to suit your application.

We can offer any material, surface finish and levels of traceable certification.

The options are endless and only constrained by quality and safety.

Contact Norbar for more details.







ULTRASONIC MEASUREMENT



Delta Sigma 124



The basic principle behind this method of tension control is similar to sonar. The ultrasonic measurement of bolt tension is achieved by introducing a sonic pulse at one end of the fastener and accurately measuring the time of flight (TOF) required for the echo to return from the opposite end. Using material constants, the Delta Sigma converts this TOF into an 'acoustic length' of the fastener, providing a baseline from which future measurements will be made. When the fastener is tightened: the TOF increases and the Delta Sigma will again utilise material constants to eliminate the effects of stress and temperature variations on sound velocity, providing an accurate elongation or load measurement.

The Delta Sigma uses state-of-the-art hardware and digital signal processing to achieve these measurements with maximum automation, minimizing the need for operator interpretation. Once measurements have been recorded to the Delta Sigma internal memory, the included software will transfer the data to a computer for backup of files, creation of project reports, and conversion of data to Excel format for further analysis. In addition, the analogue signal output can be used to automatically shut-off powered torque and tensioning tools based on elongation or load, in even the most demanding applications.

| | | |
|-----------------|-----------------|-----|
| Model | USM Delta Sigma | |
| Part Number | 44539 | |
| Dimensions (mm) | A | 41 |
| | B | 175 |
| | C | 180 |
| Weight (kg) | 1.5 | |

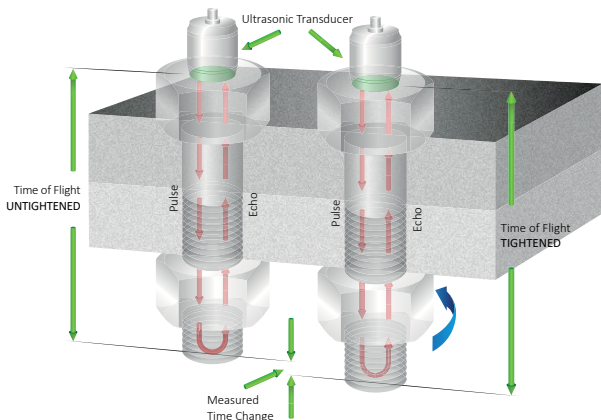

9 DELTA SIGMA KIT & TRANSDUCER

44539.KIT Delta Sigma unit, canvas case, ultrasonic couplant, temperature probe, transducer cable, 1 x transducer of customer's choice all enclosed in a peli case

9 DELTA SIGMA BASE KIT

44539 Delta Sigma unit, canvas case, ultrasonic couplant, temperature probe and transducer cable all enclosed in a peli case

The Delta Sigma under the settings allows for a voltage output of between 0 to 10 Volts against bolt elongation and can be plotted into any logger with a voltage input.

Magnetic Transducers - This standard style is used with ferrous materials, and consists of a rare earth magnet surrounding the piezo electric transducer.

9 TRANSDUCERS

| | |
|-------|--|
| 56016 | 3/16" 5 MHz Magnetic Transducer |
| 56017 | 3/16" 7.5 MHz Magnetic Transducer |
| 56018 | 3/16" 10 MHz Magnetic Transducer |
| 56009 | 1/4" 5 MHz Magnetic Transducer |
| 56019 | 1/4" 10 MHz Magnetic Transducer |
| 56011 | 1/2" 2.25 MHz Magnetic Transducer |
| 56010 | 1/2" 5 MHz Magnetic Transducer |
| 56020 | 3/4" 1 MHz Magnetic Transducer |
| 56013 | 3/4" 2.25 MHz Magnetic Transducer |
| 56012 | 3/4" 5 MHz Magnetic Transducer |
| 56021 | Glue on, 3 mm square, 7.5 MHz, pack of 100 |

Operating temperature limit for transducers is 55°C. Contact Norbar for details of high temperature transducers with a temperature limit of 175°C.

9 SPARES & ACCESSORIES

| | |
|-------|----------------------------|
| 60350 | Temperature Probe |
| 60349 | Transducer Cable |
| 61910 | Ultrasonic Couplant Bottle |
| 56024 | Pencil Probe |

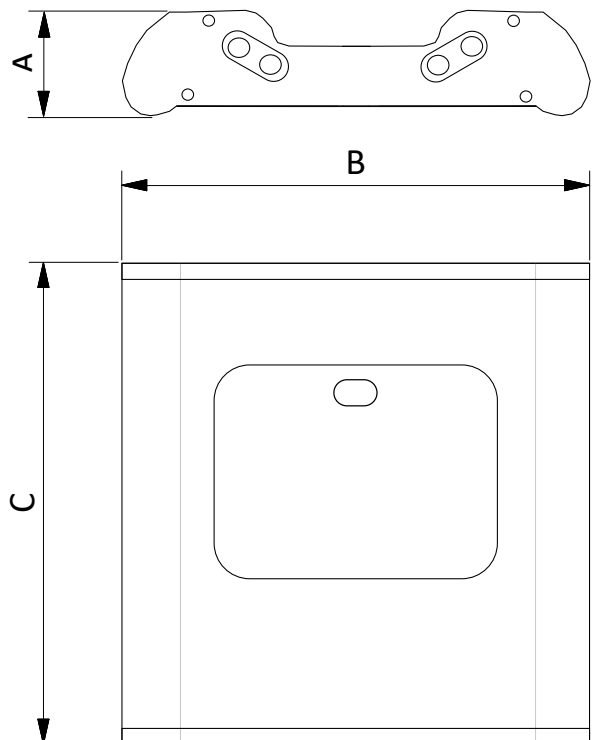

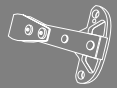

CALIBRATION BEAMS & WEIGHTS

Calibration Beams & Weights - Principles of Operation 126
 Calibration Beams & Weights - Metric 127
 Calibration Beams & Weights - Imperial 128
 Calibration Certificates 129

Designed to remove potential sources of measurement error, these beams can be used to calibrate Norbar torque transducers, and torque transducers from other manufacturers (where design permits), as well as mechanical test devices. A UKAS accredited calibration certificate for the measurement of the torque radius is provided with each beam.

The Norbar technical team can assist in mass and beam selection.

- Tel: +44 (0)1295 753635
- Fax: +44 (0)1295 753636
- Email: TechSales@norbar.com



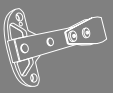

Norbar's test beams are designed for the static calibration of torque transducers. They are ideally suited to Norbar's transducers, but can be employed on other manufacturer's equipment.

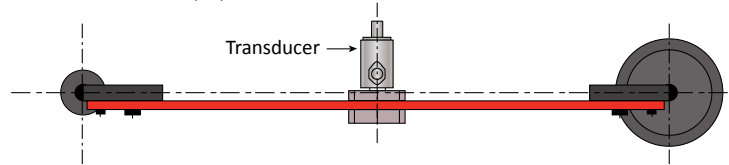

Torque is generated by the application of a known force at a known radius from the centre of rotation of the torque transducer.

The beams are designed with square drives machined to the top limit of ISO 1174. This minimises any play between the beam and the transducer. However, a combination of square drive tolerances, misalignment of fittings and elastic rotation of the transducer shaft inevitably cause the beam to rotate from the horizontal under load.

Norbar's radius ended beams are designed with a $\pm 8^\circ$ usable arc. Using the full 8° , calibrations to a best class of 0.5 can be carried out. With additional use of Clamping Bench Stands (see page 128), a best class of 0.1 can be achieved.

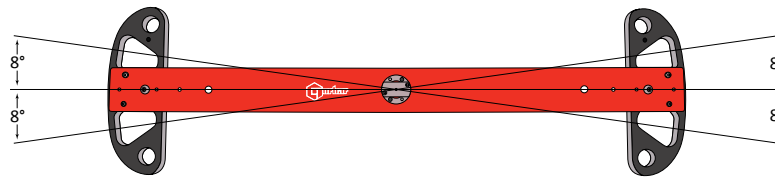
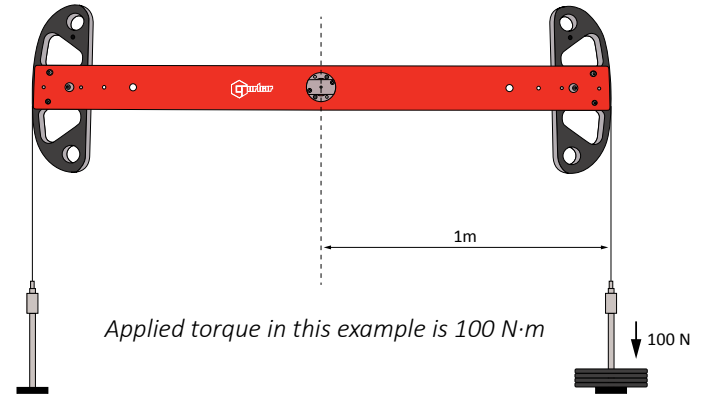

Additionally, the beams are designed to apply load on a vertical plane which cuts through the square drive inside the transducer. This minimises bending moments on the transducer and for safe operation, ensures that the beam will not fall out of the transducer.

Gravitational Effects

It is very important that the gravitational value for the laboratory is established. The effect of not doing this could be a variation in the force produced by the weight of perhaps 0.5% of reading.

It is therefore strongly recommended that you establish the local value of gravity (g) for your laboratory and use weights that have been calibrated at that gravitational constant.

Norbar will supply weights calibrated to gravitational constants specified by the customer. However, if the customer does not specify a value for ' g ' they will have been calibrated at an estimated gravitational constant for the customers' location.

Buoyancy Effects

The Norbar system uses calibrated weights to generate a downwards force.

This means that Archimedes' principle applies, i.e. air pressure under the weights causes an upwards force. This reduces the effective force generated by the weights and therefore the mass must be increased to allow for this.

Under standard conditions (i.e. air density 1.2 kg/m^3 and 20° Celsius and working in conventional mass terms) the increase required is by a factor of 0.015%.

Weights purchased from Norbar will already have this factor taken into account.

Weights that are calibrated to standard procedures do not have this factor taken into account because the air buoyancy affects both sides of the mass balance and can be ignored. It is important that weights used for torque transducer calibration are adjusted for air buoyancy.

It should also be noted that the double ended beam design employed by Norbar means that each half of the beam is balanced with regard to buoyancy of the beam. This is a significant advantage over single-arm counterbalanced systems.

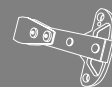

CALIBRATION BEAMS & WEIGHTS - METRIC



Calibration details

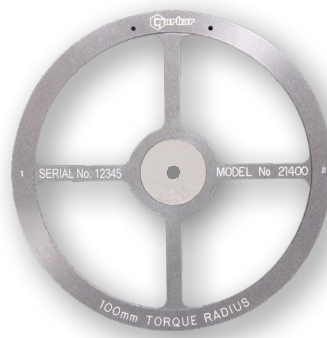

Right: 21400 Torque Radius Disc (100mm)

| 9 METRIC - NEWTON METRE SIZES | | |
|-------------------------------|-----------|-----------------------------|
| 21400 | 3 N·m | Torque Radius Disc (100 mm) |
| 21429 | 60 N·m | Radius Ended Beam (0.25 m) |
| 21421 | 150 N·m | Radius Ended Beam (0.5 m) |
| 21427 | 500 N·m | Radius Ended Beam (0.5 m) |
| 21428 | 1,500 N·m | Radius Ended Beam (1.0 m) |
| 21842 | 7,000 N·m | Free Standing Beam |

With the exception of 21842 all calibration beams are supplied in a protective case. A UKAS accredited calibration certificate for the measurement of the torque radius is provided with each beam.

| 9 WEIGHTS FOR THE DISC 21400 | |
|------------------------------|---|
| 21452.NAM | Brass weight set to give 0.5 N·m (10 x 0.5 N) |
| 21450.NAM | Brass weight set to give 1.0 N·m (10 x 1.0 N) |
| 21479.NAM | Brass weight set to give 2.5 N·m (10 x 2.5 N) |

| 9 WEIGHTS FOR THE BEAM 21429 | |
|------------------------------|--|
| 21476.NAM | Cast iron weight set to give 5 N·m (10 x 2 N) |
| 21454.NAM | Cast iron weight set to give 10 N·m (10 x 4 N) |
| 21458.NAM | Cast iron weight set to give 50 N·m (10 x 20 N) |
| Q2343.NAM | Cast iron weight set to give 60 N·m Optimised for the Pro-Test 60 (1 x 4.8 N, 1 x 7.2 N, 1 x 12 N, 1 x 24 N, 4 x 48 N) |

| 9 WEIGHTS FOR THE BEAM 21421 | |
|------------------------------|--|
| 21477.NAM | Cast iron weight set to give 50 N·m (10 x 10 N) |
| 21458.NAM | Cast iron weight set to give 100 N·m (10 x 20 N) |

| 9 WEIGHTS FOR THE BEAM 21427/21428 | |
|------------------------------------|---|
| 21459.NAM | Cast iron weight set to give 250/500 N·m (1 x 10 N, 10 x 50 N) |
| 21460.NAM | Cast iron weight set to give 500/1,000 N·m (1 x 10 N, 10 x 100 N) |
| 21483.NAM | Cast iron weight set to give 500/1,000 & 1,500 N·m (14 x 100 N, 1 x 50 N, 2 x 20 N, 1 x 10 N) |

e.g. set 21459.NAM will give 250 N·m on a 21427 beam and 500 N·m on a 21428.

| 9 WEIGHTS FOR THE BEAM 21842 | |
|------------------------------|--|
| 21469.NAM | Cast iron weight set to give 7,000 N·m (20 x 50 lbf) |

All weight sets come with traceable UKAS accredited calibration certificate. This requires the customer to provide the value for 'g' (local gravity) for the intended place of use when ordering.



| Model | 100 mm Disc | 0.25 m Beam | 0.5 m Beam | 0.5 m Beam | 1 m Beam | Free Standing Beam | |
|----------------------|-------------|-------------|------------|------------|----------|--------------------|------------|
| Part Number | 21400 | 21429 | 21421 | 21427 | 21428 | 21842 | |
| Minimum Torque (N·m) | 0.05 | 0.5 | 5 | 50 | 10 | 350 | |
| Dimensions (mm) | A | 100 | 250 | 500 | 500 | 1,000 | * 1,573.66 |
| | B max. | 295 | 650 | 755 | 1,015 | 1,015 | 1,070 |
| Weight (kg) | 0.5 | 1.9 | 5.0 | 17.0 | 25.0 | 270.0 | |

* A max. Torque Radius for 7,000 N·m beam

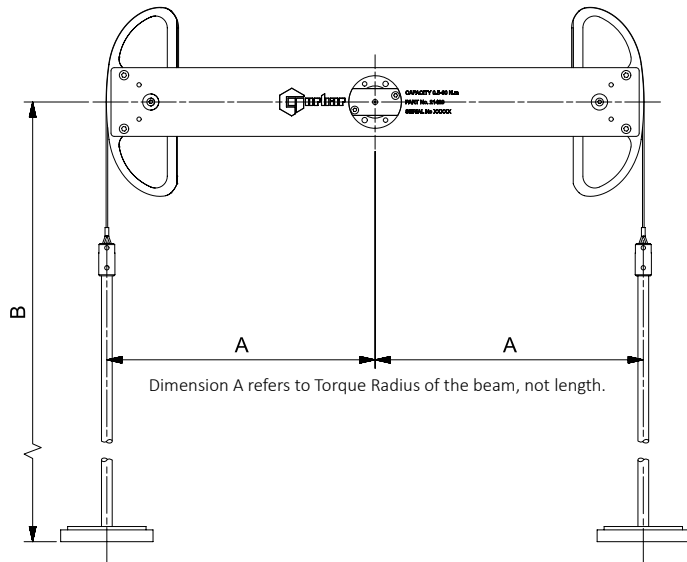

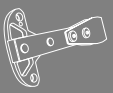

| 9 | IMPERIAL - POUNDS FEET SIZES | |
|-------|------------------------------|-----------------------------|
| 21400 | 25 lbf-in | Torque Radius Disc (100 mm) |
| 21430 | 500 lbf-in | Radius Ended Beam (10") |
| 21424 | 100 lbf-ft | Radius Ended Beam (12") |
| 21425 | 500 lbf-ft | Radius Ended Beam (24") |
| 21426 | 1,000 lbf-ft | Radius Ended Beam (48") |
| 21842 | 5,000 lbf-ft | Free Standing Beam |

With the exception of 21842 all calibration beams are supplied in a protective case. A UKAS accredited calibration certificate for the measurement of the torque radius is provided with each beam.

| 9 | WEIGHTS FOR THE DISC 21400 | |
|-----------|--|--|
| 21455.NAM | Brass weight set to give 50 ozf-in (10 x 1.27 ozf) | |
| 21453.NAM | Brass weight set to give 100 ozf-in (10 x 2.54 ozf) | |
| 21451.NAM | Brass weight set to give 160 ozf-in (10 x 4.064 ozf) | |

| 9 | WEIGHTS FOR THE BEAM 21430 | |
|-----------|--|--|
| 21465.NAM | Cast iron weight set to give 100 lbf-in (10 x 1 lbf) | |
| 21466.NAM | Cast iron weight set to give 500 lbf-in (10 x 5 lbf) | |

| 9 | WEIGHTS FOR THE BEAM 21424 | |
|-----------|---|--|
| 21467.NAM | Cast iron weight set to give 100 lbf-ft (10 x 10 lbf) | |

| 9 | WEIGHTS FOR THE BEAM 21425 | |
|-----------|---|--|
| 21468.NAM | Cast iron weight set to give 500 lbf-ft (10 x 25 lbf) | |

| 9 | WEIGHTS FOR THE BEAM 21426 | |
|-----------|---|--|
| 21468.NAM | Cast iron weight set to give 1,000 lbf-ft (10 x 25 lbf) | |

| 9 | WEIGHTS FOR THE BEAM 21842 | |
|-----------|---|--|
| 21469.NAM | Cast iron weight set to give 5,000 lbf-ft (20 x 50 lbf) | |

All weight sets come with a traceable UKAS accredited calibration certificate. This requires the customer to provide the value for 'g' (local gravity) for the intended place of use when ordering.

| Model | 100 mm Disc | 10" Beam | 12" Beam | 24" Beam | 48" Beam | Free Standing Beam |
|-----------------|-------------|-----------|-----------|-----------|------------|--------------------|
| Part Number | 21400 | 21430 | 21424 | 21425 | 21426 | 21842 |
| Minimum torque | 0.44 lbf-in | 10 lbf-in | 10 lbf-ft | 50 lbf-ft | 100 lbf-ft | 300 lbf-ft |
| Dimensions (mm) | A | 100 | 254 | 305 | 610 | * 1,524 |
| | B max. | 295 | 650 | 690 | 965 | 1,015 |
| Weight (kg) | 0.5 | 1.2 | 3.7 | 17.3 | 26.4 | 270.0 |

* A max. Torque Radius for 5,000 lbf-ft beam

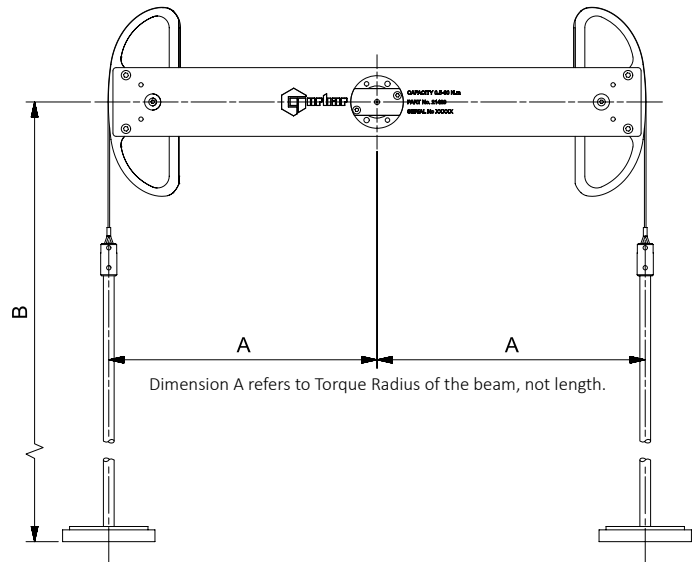

| 9 | ANCILLARY PRODUCTS FOR CALIBRATION BEAMS | |
|-------|--|--|
| J2676 | 1,500 N-m Calibration Pedestal | |
| J2329 | Pro-Test Calibration Test Rig Assembly | |
| 80005 | Adjustable Angle Attachment | |

| 9 | CLAMPING BENCH STAND | |
|-------|--|--|
| J4684 | 3/8" Clamping Bench Stand for use with J2329 | |
| J4683 | 1/2" Clamping Bench Stand for use with J2329 | |
| J4685 | 3/4" Clamping Bench Stand for use with J2329 | |
| J4682 | 1" Clamping Bench Stand for use with J2329 | |
| J4120 | 1" Clamping Bench Stand for use with J2329 | |
| J2329 | Protest Calibration System Base for Adaptors including Balancing Gearbox | |



CALIBRATION CERTIFICATES



As a UKAS accredited calibration Laboratory No. 0256, Norbar is required to calibrate torque measuring devices that are within the laboratory's scope, in accordance with BS 7882:2017. See the 'UKAS Schedule of Accreditation' on the 'Calibration Services' page of our website, www.norbar.com.

Norbar can provide a comprehensive range of calibrations including increasing and decreasing torques; clockwise and counter-clockwise; in either SI or English torque units, or in mV/V or Volts.

The sections below summarise the main features of BS 7882:2017, but purchase and careful study of the standard is advised for those who wish to have more detailed information.

Procedure

- The 'device' is defined as all parts of a system, e.g. Display, Transducer cable and Transducer. Transducer cables will therefore be serial numbered if they are separate items.
- The output of the device is defined as 'deflection'.
- It is preferable to calibrate all parts of a system together. If a transducer is sent for calibration without its normal display unit, an equivalent calibrated display held in the laboratory will be used. The normal display must also be in a calibrated state or the certification for the transducer is invalidated.
- Norbar is currently the only laboratory accredited by UKAS for the calibration of Electrical Torque Measuring Indicators.
- Before any calibration or recalibration the torque measuring device is preloaded three times in succession to the maximum applied torque of the device. Each preload is maintained for a minimum of 30 seconds to exercise the device and stabilise it in the calibration fixture.
- The device is calibrated with at least five approximately equal steps from 20% to 100% of maximum torque. Lower values are allowed as long as they meet certain criteria for resolution.
- For classes 0.05 and 0.1, it is mandatory to calibrate the torque measuring device in four different mounting positions each rotated 90° about the measurement axis. For all other classes the device is calibrated at a minimum of two different mounting positions at least 90° apart.
- Two series of readings are taken, and the device is then disturbed, generally by being disconnected from the calibration fixture and rotated through 90°. The device is then preloaded once to full scale. A third series of readings are then taken. This process is repeated until readings have been recorded in all required orientations.
- If reversibility is required, a single series of decreasing torques are applied at the end of the last increasing series.
- Should calibration be required in both directions, the series of readings are repeated in the opposite direction.
- The calibration data is then analysed to establish the following parameters.

Repeatability

The variation between the indicated deflection from series 1 and 2, expressed as a percentage of the mean of the two readings.

Reproducibility

The maximum variation between series 1, 2 and 3, or series 1, 2, 3, 4 and 5 expressed as a percentage of the mean indicated deflection calculated from series 1, 3 or series 1, 3, 4, and 5.

Error of Indication

Where the results are expressed in units of torque, the errors of indication are the variation between each applied torque and the mean indicated deflection at that torque.

Error of Zero Torque

The maximum zero reading recorded after each loading series is expressed as a percentage of the maximum mean indicated deflection.

Error of Interpolation

Where the results are expressed in volts or units other than torque units, a second order polynomial equation (best fit line) is established and the difference in deflection from the computed value is expressed as a percentage of the computed value.

Reversibility

The variation between the readings from the last torque series applied in an increasing mode and the readings for the same given torque applied in a decreasing mode. Reversibility is expressed as a percentage of the deflection of the last increasing series for the given torque.

Classification

- The parameters are each compared with a table to establish the device's classification. Class 0.05 is the highest performance, and class 5 is the lowest defined by the standard. The overall class reported will be that of the lowest performing parameter. For example reproducibility may be a class 1 when all other parameters meet class 0.5. The device will be classified as 1.
- Additionally the uncertainty of measurement of the applied torque must be five times better than the overall class reported. Norbar's uncertainty of measurement (typically 0.02%) allows classification to Class 0.1 devices.
- Different classes may be quoted for ranges below 20% of maximum capacity.

Relative Measurement Uncertainty Interval

The relative measurement uncertainty interval of the device is also calculated by combining the relative mean deviation with the relative expanded uncertainty.

Effectively the uncertainty interval encompasses all of a transducers reported errors and uncertainty of calibration, providing the user with a maximum error value of the calibrated device.

Accredited calibrations performed to BS 7882:2017 meet the requirements of BS EN ISO6789-2:2017 clause 4.3 and annex C 7.3, and BS EN ISO 6789-1:2017 clause 6.1.

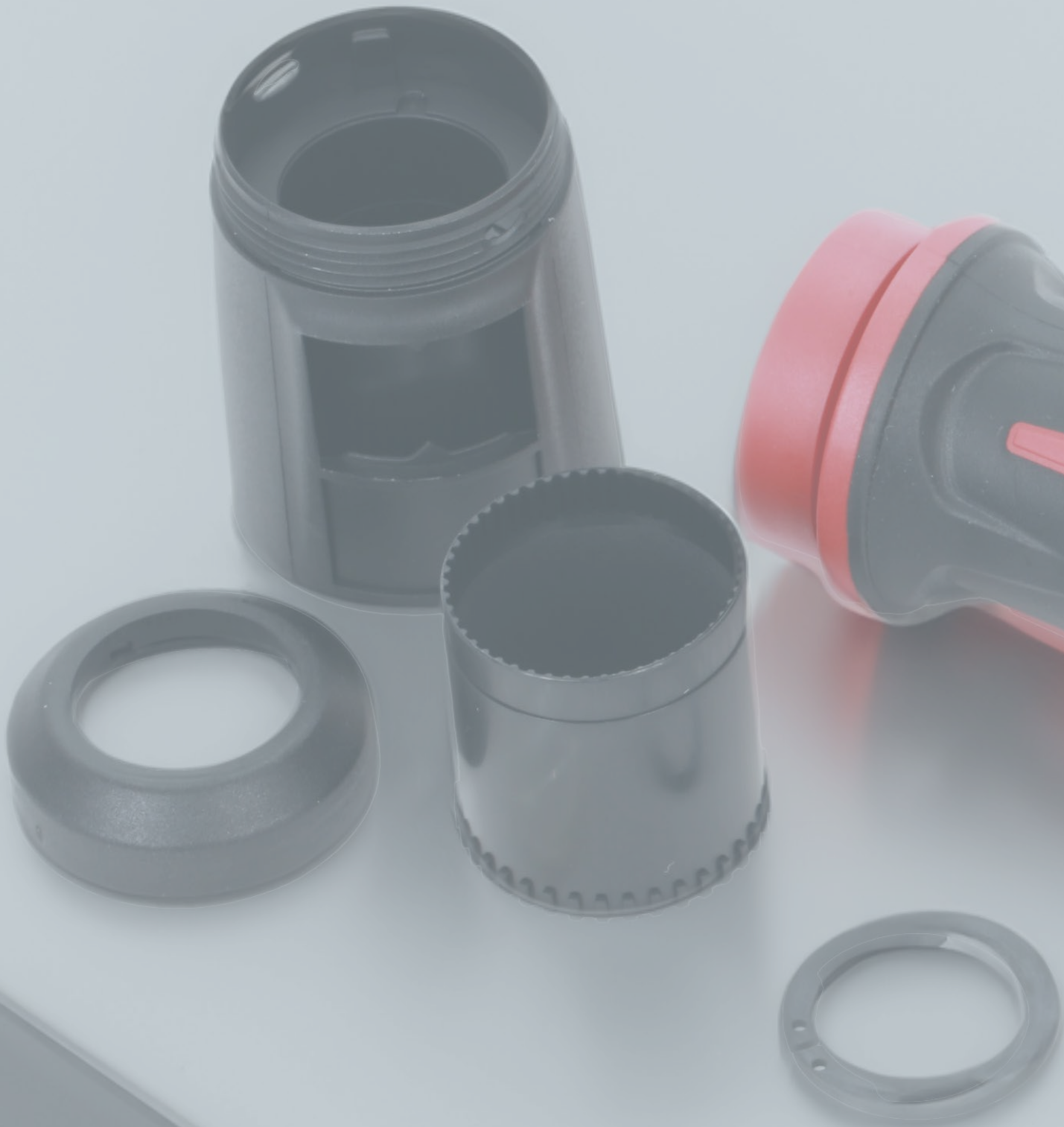
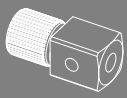

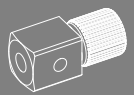

SPARES KITS

Spares Kits 132

SPARES KITS

In order to maintain the quality, performance and peace of mind associated with our products Norbar recommend that only genuine Norbar spares are fitted to our products.

SERVICE REPLACEMENT POLICY

Our aim is to give you the fastest possible service when you send in a wrench for repair. Therefore, our policy is that all Norbar wrenches will, at Norbar's discretion, either be repaired or a 'service replacement' tool will be offered. This policy may be extended to wrenches from other manufacturers sent to Norbar for repair/replacement.

Repair

Where Norbar judges that a repair is viable, a combined repair and 'declaration of conformance' (COMBO) service will be offered – see page 136 for more information. The setting of the wrench and documentation of the results will be carried out in conformance with ISO 6789-1:2017. For customers requiring a calibration certificate conforming to ISO 6789-2:2017 from Norbar's UKAS accredited laboratory, this service can also be offered at an additional cost.

Service Replacement

When Norbar judges that a repair is not commercially viable, a 'service replacement' tool will be offered. A 'service replacement' tool is manufactured from new parts, carries a twelve month warranty and is supplied with the same documentation as a new product of the equivalent type. For Professional, adjustable models from Model 15 to Model 1500 a calibration certificate conforming to ISO 6789-2:2017 will be supplied as standard from the production line. All other service replacement models, for example NorTorque® and TTI wrenches, will be supplied with a Declaration of Conformance to ISO 6789-1:2017. As with repairs, customers preferring a certificate from Norbar's UKAS accredited laboratory can specify this service at an additional cost.

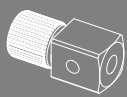

SPARES KITS

| 8 | TORQUE SCREWDRIVER |
|--------------|---|
| 13593.001NM | TTs Handle Repair Kit for 1.5 N·m Tool |
| 13593.003NM | TTs Handle Repair Kit for 3.0 N·m Tool |
| 13593.006NM | TTs Handle Repair Kit for 6.0 N·m Tool |
| 13593.013LBI | TTs Handle Repair Kit for 13 lbf·in Tool |
| 13593.026LBI | TTs Handle Repair Kit for 26 lbf·in Tool |
| 13593.053LBI | TTs Handle Repair Kit for 53 lbf·in Tool |
| 13593.P | TTs Handle Repair Kit for P Type Tool |
| 13594 | TTs Adjusting Screw & Retention Clip Repair Kit |
| 13595 | TTs Body Tube & Cam Assembly Repair Kit |
| 13596 | TTs End Knob Assembly Repair Kit |
| 13597 | TTs ¼" Blade Repair Kit |
| 13609 | TTs P Type Locking Knob Repair Kit |



| 8 | MODEL 5 |
|-------|----------------------------------|
| 13123 | Spares Kit Model 5 Adjustable |
| 13124 | Calibration Kit Model 5 'P' Type |

| 8 | SLIMLINE TORQUE WRENCHES |
|-------|---|
| 11831 | Ratchet Repair Kit SLO ¼" (post Jan 2008) |
| 11832 | Ratchet Repair Kit SLO ⅜" (post Jan 2008) |
| 11806 | Spares Kit - SLO Adj Knob |
| 11914 | ⅜" sq.dr for SLO Fixed Head |
| 11762 | Rivet Repair Kit |

| 8 | TT WRENCHES UP TO 50 N·m/35 lbf·ft |
|--------------|--|
| 13425 | ¼" Ratchet Repair Kit, Mdl 20 N·m, 180 lbf·in |
| 13426 | ⅜" Ratchet Repair Kit, Mdl 20 N·m, 180 lbf·in, 50 N·m, 35 lbf·ft |
| 13427 | ½" Ratchet Repair Kit, Mdl 50 N·m, 35 lbf·ft |
| 13636.020NLF | Handle Repair Kit, 20 N·m/lbf·in Scale |
| 13636.020NM | Handle Repair Kit, 20 N·m Scale |
| 13636.050NLF | Handle Repair Kit, 50 N·m/lbf·ft Scale |
| 13636.050NM | Handle Repair Kit, 50 N·m Scale |
| 13417 | Adjusting Knob Repair Kit |
| 13637 | Thrust Washer Repair Kit |
| 11762 | Rivet Repair Kit |



| 8 | TT WRENCHES 100 N·m/75 lbf·ft TO 300 N·m/250 lbf·ft |
|-------|---|
| 13414 | Rivet Repair Kit |

| 8 | TTfth WRENCHES |
|-------|---|
| 13695 | TTfth20 9 x 12 mm Female End Repair Kit |
| 13692 | TTfth50 9 x 12 mm Female End Repair Kit |

| 8 | TTi WRENCHES |
|-------|---|
| 13693 | TTi20 ¼" Ratchet Lever Arm Assemblies |
| 13694 | TTi20 ⅜" Ratchet Lever Arm Assemblies |
| 13690 | TTi50 ⅜" Ratchet Lever Arm Assemblies |
| 13691 | TTi50 ½" Ratchet Lever Arm Assemblies |
| 13212 | Ratchet Repair Kit, ⅜" sq. dr., 60/100 |
| 13214 | Ratchet Repair Kit, ½" sq. dr., 200 |
| 13215 | Ratchet Repair Kit, ½" sq. dr., Mdl 250/300 N·m, 185/220 lbf·ft |
| 13491 | Ratchet Replacement Kit, ⅜" sq. dr., 60/100 |
| 13492 | Ratchet Replacement Kit, ½" sq. dr., 50 - 200 |

For Handle Repair Kits please see TT section above.



150101.K

| 8 | NON-MAGNETIC RATCHET REPAIR KITS |
|-------|--|
| 13769 | Ratchet Repair Kit for 13900, 13902, 13904 & 13906 |
| 13770 | Ratchet Repair Kit for 13901, 13903, 13905 & 13907 |



13425

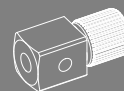

SPARES KITS

| 8 NORTORQUE TORQUE WRENCHES HANDLE KITS | |
|---|---|
| 130501.060NLF | Handle Repair Kit, 60 N-m/lbf-ft Scale |
| 130501.060NM | Handle Repair Kit, 60 N-m Scale |
| 130501.100NLF | Handle Repair Kit, 100 N-m/lbf-ft Scale |
| 130501.100NM | Handle Repair Kit, 100 N-m Scale |
| 130501.200NLF | Handle Repair Kit, 200 N-m/lbf-ft Scale |
| 130501.200NM | Handle Repair Kit, 200 N-m Scale |
| 130501.300NLF | Handle Repair Kit, 300 N-m/lbf-ft Scale |
| 130501.300NM | Handle Repair Kit, 300 N-m Scale |
| 130501.340NLF | Handle Repair Kit, 340 N-m/lbf-ft Scale |
| 130501.340NM | Handle Repair Kit, 340 N-m Scale |



13235 Repair Kit

| 8 NORTORQUE TORQUE WRENCHES SQUARE DRIVE REPAIR KITS | |
|--|--|
| 13235* | Sq. Dr. Repair Kit 3/8" (Mdl60) |
| 13236* | Sq. Dr. Repair Kit 1/2" (Mdl100) |
| 13237* | Sq. Dr. Repair Kit 1/2" (Mdl200/300/340) |

* For tools built prior to 2025

| | |
|--------|--|
| 131169 | Sq. Dr. Repair Kit 3/8" (Mdl60) |
| 131170 | Sq. Dr. Repair Kit 1/2" (Mdl100/200/300/340) |

| 8 NORTORQUE TORQUE WRENCHES RATCHET REPAIR KITS | |
|---|--------------------------------------|
| 13212* | Ratchet Repair Kit 3/8" (Mdl60) |
| 13213* | Ratchet Repair Kit 1/2" (Mdl100) |
| 13214* | Ratchet Repair Kit 1/2" (Mdl300/340) |
| 13215* | Ratchet Repair Kit 1/2" (Mdl300/340) |

* For tools built prior to 2025

| | |
|--------|--------------------------------------|
| 131171 | Ratchet Repair Kit 3/8" (Mdl60) |
| 131172 | Ratchet Repair Kit 1/2" (Mdl100/200) |
| 131173 | Ratchet Repair Kit 1/2" (Mdl300/340) |

| 8 NORTORQUE TORQUE WRENCHES OTHER REPAIR KITS | |
|---|-----------------------------|
| 130500.K | Locking Knob Kit |
| 150103.K | Thrust Washer and Screw Kit |

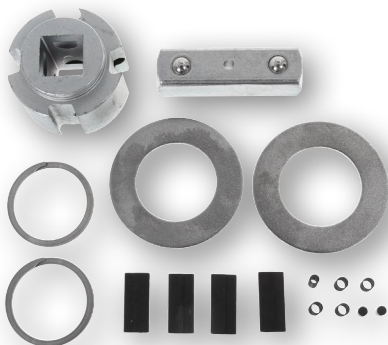

13215 Repair Kit

| 8 PROFESSIONAL TORQUE WRENCHES PRO 15 - 25 SPARES KITS | |
|--|---|
| 15395* | 'Automotive Ratchet' Repair Kit, 1/4" sq. dr. |
| 15396* | 'Automotive Ratchet' Repair Kit, 3/8" sq. dr. |
| 15397.K | Handle Repair Kit |
| 15398.K | Scale Mechanism Repair Kit |
| 15399.K | Locking Knob Repair Kit |
| 15401.K | Spring Repair Kit |

* For tools built prior to 2024

| 8 PROFESSIONAL TORQUE WRENCHES SQUARE DRIVE REPAIR KITS | |
|---|---------------------------|
| 150105.K* | 1/2" sq. dr. Mushroom Kit |
| 150106.K* | 3/8" sq. dr. Mushroom Kit |

* For tools built prior to 2025

| | |
|--------|---|
| 131169 | Sq. Dr. 'Push-Through' Repair Kit 3/8" (Mdl50) |
| 131170 | Sq. Dr. 'Push-Through' Repair Kit 1/2" (Mdl100/200/300/340) |
| 15350 | Sq. Dr. 'Push-Through' Repair Kit 3/4" (Mdl400) |

| 8 PROFESSIONAL TORQUE WRENCHES RATCHET REPAIR KITS | |
|--|---|
| 150112.K* | 'Mushroom Ratchet' Repair Kit, 3/8" sq. dr. (Pro 50) |
| 150113.K* | 'Mushroom Ratchet' Repair Kit, 1/2" sq. dr. (Pro 100 - 200) |
| 150114.K* | 'Mushroom Ratchet' Repair Kit, 1/2" sq. dr. (Pro 300 - 340) |
| 150115.K* | 'Mushroom Ratchet' Repair Kit, 3/4" sq. dr. (Pro 400) |

* For tools built prior to 2025

| | |
|--------|---|
| 131171 | 'Push-Through' Repair Kit, 3/8" sq. dr. (Pro 50) |
| 131172 | 'Push-Through' Repair Kit, 1/2" sq. dr. (Pro 100 - 200) |
| 131173 | 'Push-Through' Repair Kit, 1/2" sq. dr. (Pro 300 - 340) |
| 131174 | 'Push-Through' Repair Kit, 3/4" sq. dr. (Pro 400) |

| | |
|----------|---|
| 11598 | 'Automotive Ratchet' Repair Kit 3/8" sq. dr. (Pro 50 & 100) |
| 11618 | 'Automotive Ratchet' Repair Kit 1/2" sq. dr. (Pro 50 & 100) |
| 150111.K | 'Automotive Ratchet' Repair Kit, 1/2" sq. dr. (Pro 200) |

| 8 PROFESSIONAL TORQUE WRENCHES SPARES KITS | |
|--|--|
| 150100.K | Handle Repair Kit |
| 150101.K | Scale Mechanism Repair Kit |
| 150102.K | Locking Knob Repair Kit |
| 150103.K | Thrust Washer and Screw Kit |
| 150104.K | Spring Repair Kit |
| 254100.PK | SKT Grub M5 x 8 LG Oval Point - Pack of 50 |

| 8 PROFESSIONAL TORQUE WRENCHES SPARES PACKS | |
|---|--|
| 11521.PK | Shaped Washer - Pack of 20 |
| 11522.PK | End Stop - Pack of 10 |
| 15312.PK | End Cap - Pack of 25 |
| 25496.PK | SCR:SKT Grub M5 x 6 LG Oval - Pack of 50 |
| 25497.PK | SCR:SKT Grub M5 x 5 LG Dog Point - Pack of 50 |
| 254100.PK | SCR:SKT Grub M5 x 8 LG Oval Point - Pack of 50 |
| 25746.PK | M3 Dog Point Grub SCR - Pack of 50 |
| 25938.PK | Washer M4 STD.Flat - Pack of 100 |
| 26033.PK | Pivot Pin - Pack of 20 |
| 27029.PK | Steel Ball 3.8 mm Dia - Pack of 50 |
| 25351.10.PK | SHCS M4 x 10 LG - Pack of 50 |

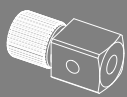

SPARES KITS

| 8 | PROFESSIONAL TORQUE WRENCHES NLD SERIES |
|-------|--|
| 14195 | Ratchet Repair Kit Mdl 550/650 ¾" |
| 14196 | Ratchet Repair Kit Mdl 800/1000/1500 ¾" |
| 14197 | Ratchet Repair Kit Mdl 800/1000/1500 1" |
| 14162 | Ratchet Assembly Mdl 550/650 |
| 14163 | Ratchet Assembly Mdl 1000 |
| 12297 | Replacement Square Drive Mdl 550/650 ¾" |
| 12299 | Replacement Square Drive Mdl 550 1" |
| 14157 | Replacement Square Drive Mdl 800 - 1500 ¾" |
| 14165 | Replacement Square Drive Mdl 800 - 1500 1" |
| 14185 | Cover Kit for all Models |
| 14218 | Secondary Lever and Support Block Assy Upgrade kit for all Models pre 2004/169391 |
| 14217 | Secondary Lever and Support Block Assy for all Models post 2004/169391 |
| 14220 | Secondary Lever Assembly |
| 14187 | Screw Adjustable Kit for all Models |
| 14166 | Calibration Kit 'P' Type for all Models |
| 13242 | Rivet Repair Kit |

| 8 | INDUSTRIAL TORQUE WRENCHES |
|--------|---|
| 12307 | Ratchet Repair Kit Industrial (except 6R & 6R-N) |
| 12373 | Ratchet Repair Kit (6R & 6R-N only) |
| 12297 | ¾" Square Drive Assy for 3AR - 5AR & 3AR-N - 5AR-N |
| 12299 | 1" Square Drive Assy for 3AR - 5AR & 3AR-N - 5AR-N |
| 18492 | 1" Square Drive Assy for 6R & 6R-N |
| 12374 | 1" Square Drive Repair Kit (6R & 6R-N only) |
| 12355 | Industrial Thrust Washer Spares Kit |
| 12360 | End Caps - Plastic 10 pack (Industrial) |
| 121125 | Replacement Rod/Plunger & Nut Assy. for 3AR |
| 121126 | Replacement Rod/Plunger & Nut Assy. for 4R |
| 121127 | Replacement Rod/Plunger & Nut Assy. for 4AR |
| 121128 | Replacement Rod/Plunger & Nut Assy. for 5R |
| 121129 | Replacement Rod/Plunger & Nut Assy. for 5AR |
| 121130 | Replacement Rod/Plunger & Nut Assy. for 6R |



In order for Norbar to supply the correct adjusting nut, we need to know the correct scale length for the tool being repaired. The scale length is denoted by a number on the nut being replaced and will be of the form e.g. 159/60.



19260 Repair Kit

| 8 | MULTIPLIER SPARES KIT |
|---------|--|
| 16831 | Spares Kit No. 2 Output Carrier |
| 16836 | Spares Kit No. 5 Output Carrier |
| 16832 | Spares Kit No. 7 Output Carrier |
| 16835 | Spares Kit No. 9 Output Carrier |
| 19348 | HT3-1000 N-m Retention Pin |
| 19349 | HT3-1000 N-m Cranked Reaction |
| 19347 | HT3-1000 N-m Straight Reaction |
| 77018.1 | Sq. Drive HT3 ¾" (old style) |
| 17185 | Spares Kit HT3 ¾" Sq Dr (Pre May 1993 style with shoulder screw) |
| 17676 | Sq. Drive HT3 ¾"(to fit 17218, 17220 & all other models with square drive retained by rollpin) |



77018.1

17676

17185

| | |
|-------|--|
| 17225 | Spares Kit HT3 ¾" Input Gear |
| 18544 | Replacement ¾" sq. dr., ET/EBT/PTS/PTM-52 Series |
| 18545 | Replacement 1" sq. dr., ET/EBT/PTS/PTM-52 Series |
| 18779 | Replacement ¾" sq. dr., ET/EBT/PTS/PTM-72 Series |
| 18492 | Replacement 1" sq. dr., ET/EBT/PTS/PTM-72 Series |
| 18221 | Replacement ¾" sq. dr., PT 72 Series |
| 18220 | Replacement 1" sq. dr., PT 72 Series |
| 19260 | Spares Kit for Fwd/Rev Gearbox Knob post Feb 2011 Tools |
| 19077 | Upgrade Kit for Fwd/Rev Gearbox for PTM |

| 8 | ET/EBT/PTS/PTM-92 & ET/EBT/PTS/PTM-119 SQUARE DRIVES |
|-------|---|
| 18934 | 1" for ET/EBT/PTS/PTM-92 |
| 18935 | 1½" for ET/EBT/PTS/PTM-92 |
| 18959 | 1½" for ET/EBT/PTS/PTM-119 |

| 8 | EBT/EBT-CA 1,100 SQUARE DRIVES |
|-------|-----------------------------------|
| 19868 | ¾" for EBT-C & EBT-CA 1,100 Tools |
| 19431 | 1" for EBT-C & EBT-CA 1,100 Tools |

| 8 | VANE SETS FOR PNEUTORQUE MULTIPLIERS |
|-----------|--------------------------------------|
| 18631 | For PTM Series (Pack of 5) |
| 18278 | For PT 72 mm Series (Pack of 6) |
| 16218 | For PT Standard Series (Pack of 6) |
| 19386 | PTS Front Endplate Kit |
| 19387 | PTS Ring Gear Kit |
| 19358 | PTS Silencer Spares Kit |
| 19357 | PTS Handle Spares Kit |
| 19308.KIT | PTS Motor Vane Kit |

| 8 | SPARES FOR LUBRO CONTROL UNIT |
|-------|-------------------------------------|
| 28911 | 3 m Hose* |
| 28912 | 6 m Hose* |
| 28913 | Pressure Gauge |
| 28914 | Filter Element for Filter/Regulator |
| 28915 | Bowl Assembly for Filter/Regulator |
| 28916 | Bowl Assembly for Lubricator |
| 28917 | Locking Collar |
| 28918 | ½" BSP Taper Thread Adaptor |

*Other lengths of hose are available, please contact Norbar for details.

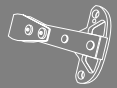

CALIBRATION SERVICES

Devices sent in for UKAS accredited calibration certification will be calibrated and the 'As Found' readings recorded. The calibration will be performed to the appropriate standard as specified in our schedule of accreditation.

- a) Should the device be in specification 'As Found', a certificate will be raised and the device returned.
- b) Should the device be out of OEM specification, but capable of adjustment, it will be adjusted, 'As Left' readings taken, and one certificate raised with 'As Found' and 'As Left' readings on it.
- c) Should the device require repair that is not covered by a combined calibration and service, we will do so where possible, after consultation with the customer.

Norbar are accredited by UKAS for torque measurements between 0.005 N·m and 108,500 N·m or the imperial equivalents. Our Schedule of Accreditation gives further details (please refer to www.norbar.com).

Accredited calibration certificates are issued under the authority of the United Kingdom Accreditation Service.

Norbar can calibrate non-Norbar Torque products, please contact us with the details of your equipment.

| | |
|---|-----|
| Declaration of Conformance | 136 |
| UKAS Accredited Calibration Certification | 136 |
| Other Certification | 139 |

A calibration 'pre-booking' service is available, please contact the Customer Relations Department a minimum of one month prior to the required recalibration due date.

- Tel: +44 (0)1295 753635
- Fax: +44 (0)1295 753636
- Email: service@norbar.com

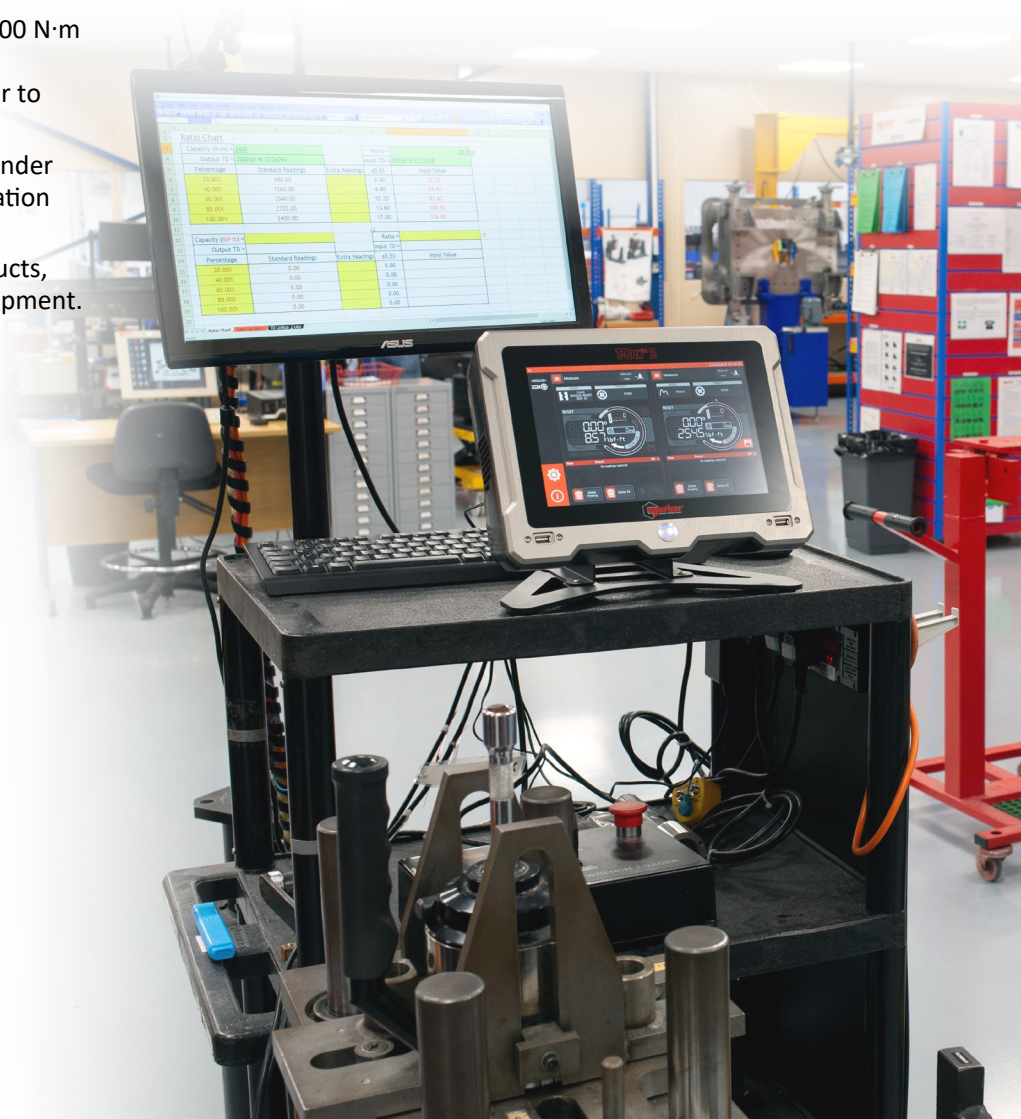



DECLARATION OF CONFORMANCE

TORQUE WRENCH (INCLUDING PROTRONIC)
DECLARATION OF CONFORMANCE (DOC)



ONE DIRECTION & REPAIR COMBO

| | |
|-----------|---|
| RDCOC1.CW | NorTorque and Professional wrenches up to 400 N·m |
| RDCOC2.CW | Industrial wrenches 2R - 5R & 3AR-N - 5R-N |
| RDCOC3.CW | All Large Professional, 5AR & 5AR-N |
| RDCOC4.CW | ProTronic Plus |



MULTIPLIER CALIBRATION AND REPAIRS

These devices are outside the schedule of accreditation issued by UKAS.

| | |
|---------|--|
| HTCERT | Compact Series Calibration |
| PTCERT | PT1 and PT2 Calibration |
| PTCERT1 | PT108 Calibration PT5 to PT9 |
| PTCERT2 | PT108 Calibration PT11 and above |
| PTSCERT | PTS Series Calibration |
| PTMCERT | PTM Series Calibration |
| PTICEC | PTM IC/EC Certificate of Air Pressure vs Torque |
| ETCERT | EvoTorque 1, 2 & EBT Certificate of Torque and Angle |
| EBTCERT | EBT Series Calibration |

This section contains combined calibration and service fixed part numbers for Norbar products. Other manufacturers' equipment will be handled by individual quotation. Provided that the product is in serviceable condition*, we guarantee to carry out all calibration, function checks and repair work in order to bring the equipment back to its original functionality.

**Product would be regarded as unserviceable if either it or the components required for the repair are obsolete or unavailable. Serviceability also implies that the product is capable of repair without complete replacement.*

| | |
|-------------|---|
| PTCERT.REP | PT1 and PT2 Fixed Price Calibration and Service |
| ETCERT.REP | EvoTorque 1 & 2 Fixed Price Calibration & Service |
| PTSCERT.REP | PTS Fixed Price Calibration and Service |
| PTMCERT.REP | PTM Fixed Price Calibration and Service |
| EBTCERT.REP | EBT Fixed Price Calibration and Service |

UKAS ACCREDITED CALIBRATION CERTIFICATION

TORQUE WRENCHES & TORQUE SCREWDRIVERS
(INCLUDING NORBAR PROTRONIC PLUS)
UKAS ACCREDITED CALIBRATION CERTIFICATION

On receipt, an 'As Found' calibration certificate will be carried out where possible. If the results do not fall within OEM specification the torque wrench or torque screwdriver will be adjusted and if the adjustment does not bring the torque tool back within specification then it will either be repaired or a service replacement will be offered – see page 131 for further details. Calibration certificates are in accordance with the current standard for hand torque tools BS EN ISO 6789-2:2017. The certificate shows the nominal torque applied and the measured torque readings.

For guidance on Norbar's procedure for torque wrenches or torque screwdrivers sent in for repair, see page 131. If the same tool is required to be returned, i.e. if you do not want the torque tool to be service replaced, then this should be made clear on the purchase order which accompanies the tool.

ONE DIRECTION

| | |
|----------|--------------------------------|
| TWCC1.CW | Up to 400 N·m / 300 lbf·ft |
| TWCC2.CW | Up to 1,000 N·m / 750 lbf·ft |
| TWCC3.CW | Up to 3,000 N·m / 2,200 lbf·ft |

TWO DIRECTIONS

| | |
|--------------|--------------------------------|
| TWCC1.CW+CCW | Up to 400 N·m / 300 lbf·ft |
| TWCC2.CW+CCW | Up to 1,000 N·m / 750 lbf·ft |
| TWCC3.CW+CCW | Up to 3,000 N·m / 2,200 lbf·ft |

NORTRONIC UKAS ACCREDITED CALIBRATION CERTIFICATION
INCLUDING PROTRONIC PLUS



ONE DIRECTION & ANGLE

| | |
|-----------|---------------------|
| NTCCS1.CW | NorTronic all sizes |
|-----------|---------------------|

TWO DIRECTIONS & ANGLE

| | |
|---------------|---------------------|
| NTCCS1.CW+CCW | NorTronic all sizes |
|---------------|---------------------|

MANUAL TORQUE MULTIPLYING GEARBOXES, UKAS ACCREDITED
CALIBRATION CERTIFICATION



The part numbers shown below are for Certification 'As Found',

ONE DIRECTION

| | |
|----------|--------------------------------|
| HTCC1.CW | Up to 6,000 N·m / 5,000 lbf·ft |
| SWEENEY | Models 8100 and 8200 |

TWO DIRECTIONS

| | |
|--------------|--------------------------------|
| HTCC1.CW+CCW | Up to 6,000 N·m / 5,000 lbf·ft |
|--------------|--------------------------------|

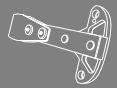

UKAS ACCREDITED CALIBRATION CERTIFICATION



ELECTRONIC DEVICES

In accordance with the current standards for calibration of torque measurement devices, it is desirable to calibrate transducers with the display that is normally used. In this case the 'system' is calibrated. If it is not possible to supply the display unit, an equivalent calibrated display unit from the laboratory will be used. The calibration will then be valid for the transducer with the original display as long as the original display has been calibrated within the last 24 months.

Calibration certificates are in accordance with the current standard for torque measuring devices BS 7882:2017, and show the nominal torque applied, and the measured torque readings. Measured readings may be given in mV/V on request. Details of the standard are available on request.

It is not our intention to offer a full repair service for torque devices from other manufacturers. Where a device is in need of repair, the customer is advised to have this performed by an approved service agent or the manufacturer before submitting the device for UKAS accredited calibration. Some electronic transducer systems from other manufacturers may incur an additional calibration cost; the electronics department repair technicians will clarify this point if required. Occasionally it will be necessary to manufacture special adaptors to enable the calibration to be performed. This will of course affect the price and delivery, and will be discussed with the customer as the need arises.

CALIBRATION TO BS7882:2017 CLASS 0.1

Norbar's UKAS accredited laboratory performs standard calibrations on torque measuring devices to BS 7882:2017 class 0.2 increasing torques only. However the laboratory is able to calibrate devices to class 0.1 at the customer's request. Class 0.1 requires calibration in four different mounting positions each rotated 90° about the measurement axis. Classification to class 0.1 is dependent on the devices performance. Calibrations including a decreasing series of torques can also be provided if required. A price for these services is available on request.

This section contains combined calibration and service fixed part numbers for Norbar products. Other manufacturers' equipment will be handled by individual quotation. Provided that the product is in serviceable condition*, we guarantee to carry out all calibration, function checks and repair work in order to bring the equipment back to its original functionality.

*Product would be regarded as unserviceable if either it or the components required for the repair are obsolete or unavailable. Serviceability also implies that the product is capable of repair without complete replacement.

Service replacements are available for some products.

ELECTRONIC TORQUE TRANSDUCERS, UKAS ACCREDITED CALIBRATION CERTIFICATION (WITH SQUARE DRIVE, FLANGE MOUNTED & PRE 2004 ROTARY)



The part numbers shown below are for Combined Calibration and Service, 'As Found' and 'As Left'

ONE DIRECTION

| | |
|------------------|---|
| TDCCS1.CW | Up to 1,500 N·m / 1,000 lbf·ft |
| TDCCS5.CW | From 1,501 to 7,000 N·m / 1,001 - 5,000 lbf·ft |
| TDCCS3.CW* | Square/Splined Drive From 7,001 to 100,000 N·m / 5,001 to 100,000 lbf·ft |
| TDCCS4.CW* | Flange Drive From 7,001 to 100,000 N·m / 5,001 to 100,000 lbf·ft |
| ADDCALPOINTS.CCS | Additional calibration steps below 10% of rated capacity to 2% for transducers up to 7,000 N·m (5,000 lbf·ft) |

TWO DIRECTIONS

| | |
|----------------|--|
| TDCCS1.CW+CCW | Up to 1,500 N·m / 1,000 lbf·ft |
| TDCCS5.CW+CCW | From 1,501 to 7,000 N·m / 1,001 - 5,000 lbf·ft |
| TDCCS3.CW+CCW* | Square/Splined Drive From 7,001 to 100,000 N·m / 5,001 to 100,000 lbf·ft |
| TDCCS4.CW+CCW* | Flange Drive From 7,001 to 100,000 N·m / 5,001 to 100,000 lbf·ft |

ROTARY TRANSDUCERS (2004 ONWARDS), UKAS ACCREDITED CALIBRATION CERTIFICATION (PART CODE 50708.XXX-50724.XXX)



The part numbers shown below are for combined calibration and service, 'As Found' and 'As Left'

ONE DIRECTION

| | |
|-----------|--------------------------------|
| TDCCS2.CW | Up to 1,500 N·m / 1,000 lbf·ft |
|-----------|--------------------------------|

TWO DIRECTIONS

| | |
|---------------|--------------------------------|
| TDCCS2.CW+CCW | Up to 1,500 N·m / 1,000 lbf·ft |
|---------------|--------------------------------|

+ UKAS accredited calibration up to 80,000 lbf·ft. A non-accredited value at 100,000 lbf·ft is extrapolated and provided for reference only.

For part numbers TDCCS3.CW and TDCCS4.CW, static transducers with 2½" square drives and annular transducers to fit HT/PT 9 & HT/PT 11, a secondary calibration to extend the range below 10% of the rated capacity may be ordered using part number TDCCS5.CW

For part numbers TDCCS3.CW+CCW and TDCCS4.CW+CCW, static transducers with 2½" square drives and annular transducers to fit HT/PT 9 & HT/PT 11, a secondary calibration to extend the range below 10% of the rated capacity may be ordered using part number TDCCS5.CW+CCW



Calibration details



TRUCHECK VERSIONS 1 & 2



The part numbers shown below are for combined calibration and service, 'As Found' and 'As Left'

ONE DIRECTION

| | |
|------------|---|
| TCCCS1.CW | TruCheck versions 1 & 2 All Sizes up to 1,500 N-m (UKAS Accredited Calibration Certification) |
| TCCCS3.CW | TruCheck versions 1 & 2 All Sizes over 1,500 N-m (UKAS Accredited Calibration Certification) |
| TCCCS2.CW* | TruCheck versions 1 & 2 All Sizes up to 1,500 N-m |
| TCCCS4.CW* | TruCheck versions 1 & 2 All Sizes over 1,500 N-m |

TWO DIRECTIONS

| | |
|---------------|---|
| TCCCS1.CW+CCW | TruCheck versions 1 & 2 All Sizes up to 1,500 N-m (UKAS Accredited Calibration Certification) |
| TCCCS3.CW+CCW | TruCheck versions 1 & 2 All Sizes over 1,500 N-m (UKAS Accredited Calibration Certification) |

*Issued with traceable certification.

PRO-TEST, UKAS ACCREDITED CALIBRATION CERTIFICATION



The part numbers shown below are for combined calibration and service, 'As Found' and 'As Left'

ONE DIRECTION

| | |
|-----------|--------------------|
| PROCCS.CW | Pro-Test All sizes |
|-----------|--------------------|

TWO DIRECTIONS

| | |
|---------------|--------------------|
| PROCCS.CW+CCW | Pro-Test All Sizes |
|---------------|--------------------|

PRO-LOG, TTT, T-BOX, T-BOX XL, T-BOX 2 & TTL-HE, UKAS ACCREDITED CALIBRATION CERTIFICATION



The part numbers shown below are for combined calibration and service, 'As Found' and 'As Left'

ONE DIRECTION

| | |
|-------------|----------------|
| INSTCCS3.CW | Pro-Log or TTT |
|-------------|----------------|

TWO DIRECTIONS

| | |
|-----------------|---|
| INSTCCS3.CW+CCW | Pro-Log or TTT |
| INSTCCS4.CW+CCW | TTL-HE, T-Box, T-Box XL or TWC Auto Control Box |
| INSTCCS5.CW+CCW | T-Box 2 |
| ANBCC.CW+CCW | AnB Module (Calibration Certification only) |

TST, UKAS ACCREDITED CALIBRATION CERTIFICATION



The part numbers shown below are for combined calibration and service, 'As Found' and 'As Left' This includes both an instrument and system calibration

ONE DIRECTION

| | |
|-----------|-----|
| TSTCCS.CW | TST |
|-----------|-----|

TWO DIRECTIONS

| | |
|---------------|-----|
| TSTCCS.CW+CCW | TST |
|---------------|-----|

Section with combined calibration & service ends here

CALIBRATION BEAMS & WEIGHTS, UKAS ACCREDITED CALIBRATION CERTIFICATION



The part numbers shown below are for Length Certification, 'As Found' and 'As Left'

| | |
|------------|--|
| CBLC1 | Disc or Beam up to 150 N-m / 100 lbf-ft |
| CBLC2 | Disc or Beam up to 1,500 N-m / 1,000 lbf-ft |
| CBLC3* | Disc or Beam up to 6,800 N-m / 5,000 lbf-ft |
| WEIGHT.CC1 | Calibration of Weights up to 25 kgf / 245 N / 55 lbf |

* The part number shown is for length certification, 'As Found'

MECHANICAL TORQUE TESTING DEVICES, UKAS ACCREDITED CALIBRATION CERTIFICATION



The part numbers shown below are for combined calibration and service, 'As Found' and 'As Left'

ONE DIRECTION

| | |
|----------|--------------------------------|
| MCCS1.CW | Up to 5,000 N-m / 5,000 lbf-ft |
|----------|--------------------------------|

TWO DIRECTIONS

| | |
|--------------|--------------------------------|
| MCCS1.CW+CCW | Up to 5,000 N-m / 5,000 lbf-ft |
|--------------|--------------------------------|

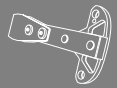

UKAS ACCREDITED CALIBRATION CERTIFICATION



TWA, UKAS ACCREDITED CALIBRATION CERTIFICATION



The part numbers shown below are for Combined Calibration and Service, 'As Found' and 'As Left'

ONE DIRECTION

TWACCS.CW | TWA All Sizes

TWO DIRECTIONS

TWACCS.CW+CCW | TWA All Sizes

ETS, UKAS ACCREDITED CALIBRATION CERTIFICATION



The part numbers shown below are for combined calibration and service, 'As Found' and 'As Left'

INSTCCS1.CW | ETS

DTS, UKAS ACCREDITED CALIBRATION CERTIFICATION



ONE DIRECTION

| | |
|-------------|---|
| DTSCCS1.CW | DTS up to 7,000 N·m or 5,000 lbf·ft |
| DTSCCS2.CW* | DTS from 7,001 to 100,000 N·m / 5,001 to 100,000 lbf·ft Square and Spline drive |
| DTSCCS3.CW* | DTS from 7,001 to 100,000 N·m / 5,001 to 100,000 lbf·ft Flange drive |

TWO DIRECTIONS

| | |
|-----------------|---|
| DTSCCS1.CW+CCW | DTS up to 7,000 N·m or 5,000 lbf·ft |
| DTSCCS2.CW+CCW* | DTS from 7,001 to 100,000 N·m / 5,001 to 100,000 lbf·ft Square and Spline drive |
| DTSCCS3.CW+CCW* | DTS from 7,001 to 100,000 N·m / 5,001 to 100,000 lbf·ft Flange drive |

+ UKAS accredited calibration up to 80,000 lbf·ft. A non-accredited value at 100,000 lbf·ft is extrapolated and provided for reference only.

ETTA, UKAS ACCREDITED CALIBRATION CERTIFICATION



The part numbers shown below are for combined calibration and service, 'As Found' and 'As Left'

ETTACCS.CW | ETTA

GENERAL DEVICES, UKAS ACCREDITED CALIBRATION CERTIFICATION

EMCC | Mechanical Enclosure Meter Calibration (CW + CCW)

OTHER CERTIFICATION

ULTRASONIC MEASUREMENT DEVICE & DELTA SIGMA CERTIFICATES



These devices are outside the schedule of accreditation issued by UKAS.

USMCC | Ultrasonic Stress Meter and Delta Sigma certificate of calibration

GENERAL DEVICES

These devices are outside the schedule of accreditation issued by UKAS.

Weight Set Certificates accredited by UKAS or other certified bodies

| | |
|----------|--|
| ETSDPFT | ETS Data Printer. Function Test |
| ETSBPUFT | ETS Battery Power Unit. Function Test |
| FWSUFT | ETS or ETTA 5 Way Switch Unit. Function Test |
| TWSUFT | ETS or ETTA 2 Way Switch Unit. Function Test |

TRANSDUCER CONVERSIONS

| | |
|--------|---|
| SQ8888 | ETS Transducer conversion to Smart Transducer (does not include calibration) |
| SQ2005 | ETTA Transducer conversion to Smart Transducer (does not include calibration) |



1. INTERPRETATION AND APPLICATION OF TERMS

1.1 In these Conditions the following words have the following meanings:

| | |
|---------------------------|---|
| “Contract” | means the contract between Norbar and the Customer for the sale and purchase of the Goods and/or Services, incorporating these Conditions, the Order and the Order Acknowledgement; |
| “Customer” | means the person(s), firm, company, entity or organisation who purchases Goods and/or Services from Norbar; |
| “Customer Equipment” | means equipment belonging to the Customer which is the subject of Services to be carried out under a Contract or which are to be incorporated into any Goods; |
| “Delivery Point” | means the address within the UK mainland which is notified to Norbar as the place for delivery of the Goods and/or Customer Equipment; |
| “Engineer to Order Goods” | means any non-standard Goods specifically designed, modified and/or made for the Customer or to the Customer’s specification; |
| “Goods” | means the goods set out in the Order to be supplied by Norbar to the Customer (including any part or parts of them and, if applicable, any Customer Equipment); |
| “Norbar” | means Norbar Torque Tools Limited (380480), whose registered office address is at Wildmere Road, Banbury, Oxon, OX16 3JU; |
| “Order” | means the order for the Goods and/or Services placed on Norbar by the Customer; |
| “Order Acknowledgement” | means the acknowledgement of Order issued by Norbar to the Customer; |
| “Services” | means the services set out in the Order to be performed by Norbar for the Customer. |

1.2 Subject to any variation under Condition 1.4 the Contract will be on these Conditions, the Order and the Order Acknowledgment to the exclusion of all other terms and conditions. They supersede any previously issued terms and conditions of supply. If there is any discrepancy between these Conditions and the Order Acknowledgement, the latter will prevail to the extent necessary to resolve the inconsistency.

1.3 No terms or conditions endorsed upon, delivered with or contained in the Customer’s Order, confirmation of order, specification or other document will form part of the Contract.

1.4 These Conditions apply to all of Norbar’s sales and any variation to these Conditions and any representations about the Goods and/or Services will have no effect unless expressly agreed in writing and signed by an authorised representative of Norbar. The Customer acknowledges that it has not relied on and will have no remedy in respect of any statement, promise or representation made or given by or on behalf of Norbar which is not set out in the Contract. Nothing in this Condition will exclude or limit Norbar’s liability for fraudulent misrepresentation.

1.5 Each Order or acceptance of a quotation for Goods or Services submitted by the Customer to Norbar will be deemed to be an offer by the Customer to purchase Goods and/or Services subject to these Conditions. No Order will be deemed to be accepted by Norbar until a written Order Acknowledgement is issued by Norbar at which point the Contract shall come into existence.

1.6 Any quotation is given on the basis that no Contract will come into existence until Norbar despatches an Order Acknowledgement. Any quotation is valid for a period of 30 days only from its date, provided that Norbar has not previously withdrawn or amended it.

2 DESCRIPTION

2.1 The description of the Goods will be as set out in Norbar’s catalogue or other published specification current at the time that the relevant Order is accepted by Norbar or, in the case of Services and Engineer to Order Goods, as specified in the relevant quotation or Order Acknowledgement. If there is any inconsistency between the published specification, the quotation and the Order Acknowledgement, the Order Acknowledgement will take precedence over the quotation which will take precedence over the published specification to the extent necessary to resolve the inconsistency.

2.2 Norbar reserves the right to make any changes to the specification of the Goods (including Engineer to Order Goods) and/or Services which are required to conform with any applicable statutory or regulatory requirements or which do not materially affect their quality or performance. The Customer will not be permitted to reject Goods and/or Services and Norbar will have no liability to the Customer in respect of any failure of the Goods and/or Services to comply with any specification in these circumstances.

2.3 The Customer acknowledges that all intellectual property rights in the Goods (including Engineer to Order Goods) and in any novel combinations or applications of the Goods (whether as a kit, system or otherwise) or which arise in the course of conducting the Services belong solely to Norbar and, to the extent that any such rights do not automatically vest in Norbar by operation of law, hereby assigns and agrees to assign to Norbar all such rights. The Customer will take any action and execute any document reasonably required by Norbar to give full effect to this Condition.

3 DELIVERY

3.1 In the case of sales of Goods within the UK mainland, delivery will take place:

- if the Goods are to be collected, on delivery to the Customer or to the Customer’s named carrier at Norbar’s premises at Wildmere Road, Banbury, Oxon OX16 3JU; and
- in all other cases, on delivery to the Delivery Point.

In the case of sales outside the UK mainland (including non-mainland UK) sales will be delivered Ex Works Norbar’s premises at Wildmere Road, Banbury, Oxon OX16 3JU (INCOTERMS 2020 edition), except where otherwise agreed in writing.

3.2 All Services will be performed at Norbar’s premises at Wildmere Road, Banbury, Oxon OX16 3JU unless otherwise agreed in writing and the Services will be deemed to be performed on completion of the performance of the Services as specified in the Order Acknowledgement.

3.3 Any dates specified by Norbar for delivery of the Goods or performance of the Services are intended to be an estimate only and time for delivery will not be made of the essence by notice. If no dates are so specified, delivery will be within a reasonable time. The Goods and/or Services may be delivered by instalments.

3.4 Norbar will have no liability for any delay in the delivery of the Goods or performance of the Services to the extent that it is caused by any omission or delay on behalf of the Customer, including any delay in the provision of any Customer Equipment.



TERMS & CONDITIONS - AUGUST 2023

- 3.5 If for any reason the Customer will not accept delivery of any of the Goods when they are ready for delivery, or Norbar is unable to deliver the Goods on time because the Customer has not provided appropriate instructions, documents, licences or authorisations then, without prejudice to any other right or remedy available to Norbar:
- risk in the Goods will pass to the Customer;
 - the Goods will be deemed to have been delivered; and
 - Norbar may store the Goods until delivery whereupon the Customer will be liable for all related costs and expenses (including, without limitation, storage and insurance).

- 3.6 The Customer has no right to cancel an Order once an Order Acknowledgment has been issued, but Norbar may, at its discretion, accept cancellation of any Order or returns of Goods ordered in error or no longer required, subject to the payment of a handling charge of 15% of the order value (excluding VAT), except that:

- Production 'P' type wrenches and screwdrivers may not be cancelled or returned;
- Goods supplied with a UKAS accredited or traceable calibration certificate will be subject to a recalibration charge in addition to the handling charge;
- Engineer to Order Goods may be charged for up to 100% of full price.

Goods returned for credit will only be accepted if they are returned in the original packaging, in a new, unused condition, carriage paid within 30 days after the despatch date.

4 NON DELIVERY

- The quantity of any consignment of Goods as recorded by Norbar upon despatch from Norbar's place of business will be conclusive evidence of the quantity received by the Customer on delivery unless the Customer can provide conclusive evidence proving the contrary.
- Norbar will not be liable for any non delivery of Goods (even if caused by Norbar's negligence) unless written notice is given to Norbar within 14 days of the date when the Goods would, in the ordinary course of events, have been received.
- Any liability of Norbar for non delivery of the Goods will be limited to replacing the Goods within a reasonable time or issuing a credit note at the pro rata Contract rate against any invoice raised for such Goods.

5 RISK/TITLE

- The Goods are at the risk of the Customer from the time of delivery.
- Ownership of the Goods will not pass to the Customer until Norbar has received in full (in cleared funds) all sums due to it in respect of the Goods and all other sums which are or which become due to Norbar from the Customer on any account.
- Until ownership of the Goods has passed to the Customer, the Customer will hold all Goods on a fiduciary basis as Norbar's bailee and Norbar will be entitled at any time:
 - to require (at no cost to Norbar) that the Goods are stored separately and clearly marked in such a way that they will readily be seen to be the property of Norbar; and/or
 - to require the Customer to deliver up the Goods or any part of them to Norbar and if the Customer refuses to do so, to immediately repossess them; and/or
 - to enter any premises or vehicle (by its employees or agents and in the case of premises, with or without vehicles) where Goods still owned by Norbar are stored or reasonably thought to be stored in order to inspect and/or repossess them.

- Norbar will be entitled to recover payment for the Goods ordered notwithstanding that ownership of the Goods has not passed from Norbar.
- The Customer may resell the Goods before ownership has passed to it providing that any such sale is made in the ordinary course of its business at full market value and the Customer is not aware that an event specified in Condition 5.6(a) has occurred or is likely to occur.
- Until ownership of the Goods has passed to the Customer, the Customer's right to possession of the Goods will terminate immediately if:
 - the Customer is made bankrupt or petitions for its own bankruptcy, or has a receiver, administrative receiver or administrator appointed over all or any of its assets or undertaking or, other than for the purposes of a solvent amalgamation or reconstruction, enters into liquidation, enters into any composition or arrangement with or for the benefit of its creditors or ceases to carry on business; or
 - the Customer fails to observe or perform any of its obligations under the Contract or any other contract between Norbar and the Customer; or
 - the Customer encumbers or in any way charges any of the Goods.
- Ownership of all Customer Equipment will remain the property of the Customer throughout the provision of the Services. Subject to Condition 6.2, Norbar will take reasonable care to safeguard the Customer Equipment and no less care than it takes to safeguard its own similar property.
- On termination of the Contract for any reason, Norbar's rights under this Condition 5 will remain in effect.

6 PRICE AND PAYMENT

- Unless otherwise agreed by Norbar in writing the price for the Goods and/or Services will be the price set out in Norbar's price list current as at the date of delivery of the Goods or performance of the Services or will be as set out in any quotation provided by Norbar.
- The price given in the current Norbar price list for calibration and repair services or in any quotation for such Services is subject to the returned Customer Equipment being of serviceable condition. If the Customer Equipment is not of serviceable condition or is out of specification and cannot be adjusted or is uneconomic to repair, either a new quotation will be provided or a service replacement tool will be offered to the Customer. If the Customer does not accept the revised quotation or service replacement within 30 days, Norbar will re-quote, revising the costs as necessary. If after a further 30 days instructions have still not been received, Norbar may (at its option) either return the Customer Equipment and invoice for costs incurred or dispose of the Customer Equipment.
- The price for the Goods and/or Services will be exclusive of any value added tax which the Customer will pay in addition when it is due to pay for the Goods and/or Services. The price for Goods and Services includes the cost of delivery (or return of Customer Equipment in the case of Services) if the order (i) is for delivery on Monday to Friday (inclusive) within the UK mainland to the Customer's usual Delivery Point using Norbar's usual delivery method and (ii) has a value of over £200.00 (excluding VAT). If delivery is to Northern Ireland, the price for Goods and Services includes the cost of delivery (or return of Customer Equipment in the case of Services) if the order (i) is for delivery on Monday to Friday (inclusive) to the Customer's usual Delivery Point using Norbar's usual delivery method and (ii) has a value of over £300.00 (excluding VAT). In all other cases, the cost of delivery of Goods or return of Customer Equipment will be charged in addition and will be due for payment at the same time as payment for the Goods is due.



- 6.4 If the Customer holds an account with Norbar, payment of the price for the Goods and/or Services is due within the agreed payment terms for that account. If any amount payable is not made within 30 days after the due date in accordance with the terms of the account, Norbar may withdraw credit facilities. If the Customer does not have an account with Norbar, or if credit facilities have been withdrawn from the Customer, payment is due either at the time the Order is placed or in accordance with any payment schedule set out in the quotation and may be tendered by credit card (up to a maximum of GBP 4,999) or bank transfer. In all cases, payment must be in pounds sterling (except where otherwise agreed in writing) and must be made by the Customer directly. Norbar will not accept payments made by any third party even if the third party is a member of the same group of companies as the Customer.
- 6.5 Time for payment will be of the essence.
- 6.6 No payment will be deemed to have been received until Norbar has received cleared funds.
- 6.7 All payments payable to Norbar under the Contract will become due immediately upon termination of this Contract notwithstanding any other Condition of the Contract or any other arrangement or agreement between the parties.
- 6.8 The Customer will make all payments due under the Contract without any deduction whether by way of set-off, counterclaim, discount, abatement or otherwise unless the Customer has a valid court order requiring an amount equal to such deduction to be paid by Norbar to the Customer.
- 6.9 If the Customer fails to pay Norbar any sum due pursuant to the Contract the Customer will be liable to pay interest to Norbar on such sum from the due date for payment at the annual rate of 4% above the base lending rate from time to time of Barclay's Bank plc, accruing on a daily basis until payment is made, whether before or after any judgment.

7. WARRANTY AND LIABILITY

- 7.1 Norbar warrants that, subject to the other provisions of these Conditions upon delivery, and for a period of 12 months after the date of delivery, the Goods will:
- be of satisfactory quality within the meaning of the Sale of Goods Act 1979; and
 - comply in all material respects with the specification for them as set out in Norbar's catalogue or other published specification current at the time that the order for the Goods was accepted by Norbar.
- 7.2 Norbar warrants that, subject to the other provisions of these Conditions all Services will:
- be supplied with reasonable skill and care within the meaning of the Supply of Goods and Services Act 1982; and
 - conform in all material respects with the specification for them as set out in Norbar's catalogue or other published specification current at the time the order for the Services was accepted by Norbar (unless specifically varied in the quotation or Order Acknowledgement).
- 7.3 Norbar will not be liable for a breach of any of the warranties in Condition 7.1 unless:
- the Customer gives written notice of the defect to Norbar within 14 days of the time when the Customer discovers or ought to have discovered the defect; and
 - the Customer returns the defective Goods properly packed, carriage paid to Norbar's premises at the address given in Condition 1.1 or otherwise specified by Norbar.
- 7.4 Norbar will not be liable for a breach of the warranties in Condition 7.1 if:
- the Customer makes any further use of the Goods after giving notice of any defect; or
 - the Goods have been misused, mishandled, overloaded, amended, modified or repaired in any way by the Customer or its customers, or used for any purpose other than that for which they were designed; or
 - the defect is due to fair wear and tear or arises because the Goods have been subject to excessive use or used in an environment for which they were not designed;
 - the defect is due to the incorporation of any Customer Equipment; or
 - the Goods differ from their specification as a result of changes made to ensure they comply with applicable statutory or regulatory requirements; or
 - the Customer or its customer has failed to follow Norbar's oral or written instructions as to the storage, installation, commissioning, use, repair, calibration or maintenance of the Goods or the recommendations set out in any national or international standard applicable to the Goods or (if there are no applicable instructions or standards) good trade or engineering practice.
- 7.5 Norbar will not be liable for a breach of the warranties in Condition 7.2 unless:
- the Customer gives written notice to Norbar identifying which Services are defective in sufficient detail within 14 days of the time when the Customer discovers or ought to have discovered the defect; and
 - if the claim relates to Customer Equipment, Norbar is given a reasonable opportunity to examine the Customer Equipment and to assess the claim of defective Services,
- 7.6 Subject to Conditions 7.3 and 7.4, if any of the Goods do not conform with any of the warranties in Condition 7.1, Norbar will at its option repair or replace such Goods (or the defective part of them) or refund the price of such Goods at the pro rata Contract rate. The provisions of these Conditions will apply to any Goods that are remedied or replaced.
- 7.7 Subject to Condition 7.5 if any of the Services do not conform with any of warranties in Condition 7.2, Norbar will at its option remedy, re-perform or refund the Services that do not comply at the pro rata Contract rate. The provisions of these Conditions will apply to any Services that are remedied or re-performed for a period of 90 days with effect from the date of performance of the remedied or re-performed Services. If any repair of Customer Equipment fails within 90 days after the date on which it was returned to the Customer by Norbar, Norbar will at its option remedy, re-perform or refund the Services that do not comply at the pro rata Contract rate.
- 7.8 If Norbar complies with Condition 7.6 or 7.7 (as applicable), it will have no further liability for a breach of any of the warranties in Condition 7.1 or 7.2 in respect of such Goods and/or Services.
- 7.9 Except as provided in Conditions 7.1 and 7.2, Norbar makes no representation or warranty, whether express or implied, as to the quality or fitness for purpose of the Goods or Services and all warranties, Conditions and other terms which may be implied by statute or common law are, to the fullest extent permitted by law, excluded from the Contract.
- 7.10 Nothing in this Contract excludes or limits the liability of Norbar for:
- death or personal injury caused by Norbar's negligence; or
 - defective products under the Consumer Protection Act 1987; or
 - for fraud or fraudulent misrepresentation; or
 - any matter for which it would be unlawful for Norbar to exclude or restrict liability.



THE CUSTOMER'S ATTENTION IS DRAWN TO THE PROVISIONS OF CONDITION 7.11

- 7.11 Subject to Condition 7.10:
- a) Norbar's total liability in contract, tort (including negligence or breach of statutory duty), misrepresentation, restitution or otherwise arising in connection with the performance or contemplated performance of this Contract will be limited to the price of the Goods and/or Services; and
 - b) Norbar will not in any event be liable to the Customer for any loss of profit, loss of business or depletion of goodwill or loss of data, in each case whether direct, indirect or consequential, or any claims for consequential compensation whatsoever (howsoever caused) which arise out of or in connection with this Contract.
- 7.12 The Customer acknowledges that the price of the Goods and/or Services has been calculated on the basis that Norbar excludes and limits its liability in accordance with Condition 7.11.
- 7.13 Where the Goods and/or Services are sold under a consumer transaction the statutory rights of the Customer are not affected by these Conditions.

8. FORCE MAJEURE

Norbar reserves the right to defer the date of delivery or to cancel the Contract or reduce the volume of the Goods or Services ordered by the Customer (without liability to the Customer) if it is prevented from or delayed in the carrying on of its business due to circumstances beyond the reasonable control of Norbar including, without limitation, acts of God, governmental actions, war or national emergency, riot, civil commotion, fire, explosion, flood, epidemic, pandemic, lock-outs, strikes or other labour disputes (whether or not relating to either party's workforce), or restraints or delays affecting carriers or inability or delay in obtaining supplies of adequate or suitable materials or components.

9. NOTICES

Any notice to be given under this Contract will be in writing and will be sent by first class mail or courier within the UK, or by courier if outside the UK; in the case of Norbar to the address set out in Condition 1.1 and in the case of the Customer to the Delivery Point or such other address as the Customer may from time to time notify to Norbar for this purpose in accordance with this Condition. Notices sent as above will be deemed to have been received three working days after the date of posting (in the case of mail within the UK), and at the time of delivery in the case of courier delivery.

10. ANTI-BRIBERY AND EXPORT CONTROL

- 10.1 Both Norbar and the Customer will comply at all times with all applicable laws, regulations, orders, judicial decision, conventions and international financial institution rules regarding corruption, bribery, ethical business conduct, money laundering, political contributions, gifts and gratuities, or lawful expenses to public officials and private persons, agency relationships, commissions, lobbying, books and records and financial controls, including without limitation, the Foreign Corrupt Practices Act, a law of the United States of America and the United Kingdom Bribery Act, a law of the United Kingdom (collectively "Anti-Corruption Laws"), and will maintain in place its own policies and procedures to ensure compliance with Anti-Corruption Laws and will enforce them where appropriate.

- 10.2 The Customer will immediately notify Norbar (in writing) if a public official becomes an officer or employee of the Customer or acquires a direct or indirect interest in the Customer (and the Customer warrants that it has no foreign public officials as officers, employees or direct or indirect owners at the date of this Agreement).
- 10.3 The Customer acknowledges that some Goods may be subject to UK export control laws and may be subject to export or import regulations in other countries. The Customer will comply fully with all applicable domestic and foreign laws and regulations in connection with the sale and use of the Goods and will, at the request of Norbar, provide such information and/or documents as Norbar may reasonably request as to the intended final destination of and use for the Goods.
- 10.4 Norbar may cancel any order (even after it has been accepted) with no liability to the Customer if Norbar is not satisfied by the information provided in accordance with Condition 10.3 or otherwise has reason to believe or be concerned that any applicable export control regulations or Anti-Corruption Laws may be breached.

11. GENERAL

- 11.1 The parties to the Contract do not intend that any term of the Contract will be enforceable by virtue of the Contracts (Rights of Third Parties) Act 1999 by any person that is not a party to it, except that any Affiliate of Norbar may directly enforce any term of the Contract where "Affiliate" means any entity that directly or indirectly Controls, is Controlled by or is under common control with Norbar and "Control" means ownership of more than 50% of the issued share capital of a company.
- 11.2 Each right or remedy of Norbar under the Contract is without prejudice to any other right or remedy of Norbar whether under the Contract or not.
- 11.3 If any provision of the Contract is found by any court, tribunal or administrative body of competent jurisdiction to be wholly or partly illegal, invalid, void, voidable or unenforceable it will to the extent of such illegality, invalidity, voidness, voidability or unenforceability be deemed severable and the remaining provisions of the Contract and the remainder of such provision will continue in full force and effect.
- 11.4 The Customer will not be entitled to assign the Contract or any part of it without the prior written consent of Norbar. Norbar may assign the Contract or any part of it or sub-contract any or all of its obligations under the Contract to any person, firm or company.
- 11.5 Failure or delay by Norbar in enforcing or partially enforcing any provision of the Contract will not be construed as a waiver of any of its rights under the Contract.
- 11.6 Any waiver by Norbar of any breach of, or any default under, any provision of the Contract by the Customer will not be deemed a waiver of any subsequent breach or default and will in no way affect the other terms of the Contract.
- 11.7 The formation, existence, construction, performance, validity and all aspects of the Contract will be governed by English law and the parties submit to the non-exclusive jurisdiction of the English courts.

